

Service Manual

Tektronix

TAS 475 & TAS 485 Analog Oscilloscopes

070-8878-00

Warning

The servicing instructions are for use by qualified personnel only. To avoid personal injury, do not perform any servicing unless you are qualified to do so. Refer to the Safety Summary prior to performing service.

Please check for change information at the rear of this manual.

First Printing: October 1993

Instrument Serial Numbers

Each instrument manufactured by Tektronix has a serial number on a panel insert or tag, or stamped on the chassis. The first letter in the serial number designates the country of manufacture. The last five digits of the serial number are assigned sequentially and are unique to each instrument. Those manufactured in the United States have six unique digits. The country of manufacture is identified as follows:

B010000	Tektronix, Inc., Beaverton, Oregon, USA
E200000	Tektronix United Kingdom, Ltd., London
J300000	Sony/Tektronix, Japan
H700000	Tektronix Holland, NV, Heerenveen, The Netherlands

Instruments manufactured for Tektronix by external vendors outside the United States are assigned a two digit alpha code to identify the country of manufacture (e.g., JP for Japan, HK for Hong Kong, IL for Israel, etc.).

Tektronix, Inc., P.O. Box 500, Beaverton, OR 97077

Printed in U.S.A.

Copyright © Tektronix, Inc., 1993. All rights reserved. Tektronix products are covered by U.S. and foreign patents, issued and pending. The following are registered trademarks: TEKTRONIX, TEK, TEKPROBE, and SCOPE-MOBILE.

WARRANTY

Tektronix warrants that this product will be free from defects in materials and workmanship for a period of three (3) years from the date of shipment. If any such product proves defective during this warranty period, Tektronix, at its option, either will repair the defective product without charge for parts and labor, or will provide a replacement in exchange for the defective product.

In order to obtain service under this warranty, Customer must notify Tektronix of the defect before the expiration of the warranty period and make suitable arrangements for the performance of service. Customer shall be responsible for packaging and shipping the defective product to the service center designated by Tektronix, with shipping charges prepaid. Tektronix shall pay for the return of the product to Customer if the shipment is to a location within the country in which the Tektronix service center is located. Customer shall be responsible for paying all shipping charges, duties, taxes, and any other charges for products returned to any other locations.

This warranty shall not apply to any defect, failure or damage caused by improper use or improper or inadequate maintenance and care. Tektronix shall not be obligated to furnish service under this warranty a) to repair damage resulting from attempts by personnel other than Tektronix representatives to install, repair or service the product; b) to repair damage resulting from improper use or connection to incompatible equipment; or c) to service a product that has been modified or integrated with other products when the effect of such modification or integration increases the time or difficulty of servicing the product.

THIS WARRANTY IS GIVEN BY TEKTRONIX WITH RESPECT TO THIS PRODUCT IN LIEU OF ANY OTHER WARRANTIES, EXPRESSED OR IMPLIED. TEKTRONIX AND ITS VENDORS DISCLAIM ANY IMPLIED WARRANTIES OF MERCHANTABILITY OR FITNESS FOR A PARTICULAR PURPOSE. TEKTRONIX' RESPONSIBILITY TO REPAIR OR REPLACE DEFECTIVE PRODUCTS IS THE SOLE AND EXCLUSIVE REMEDY PROVIDED TO THE CUSTOMER FOR BREACH OF THIS WARRANTY. TEKTRONIX AND ITS VENDORS WILL NOT BE LIABLE FOR ANY INDIRECT, SPECIAL, INCIDENTAL, OR CONSEQUENTIAL DAMAGES IRRESPECTIVE OF WHETHER TEKTRONIX OR THE VENDOR HAS ADVANCE NOTICE OF THE POSSIBILITY OF SUCH DAMAGES.

Table of Contents

List of Figures	vii
List of Tables	xi
Preface	xiii
Related Manuals	xiv
Safety Summary	xv
Symbols and Terms	xv
Specific Precautions	xvi

Specifications

Product Description	1-1
User Interface	1-2
AUTOSET	1-2
Menus	1-2
General Purpose Knob and TOGGLE	1-2
Save/Recall Setups	1-2
Vertical System	1-3
Horizontal System	1-3
Trigger System	1-3
Measurement Cursors	1-3
Option 22: Additional Probes	1-4
Option 23: Additional Probes — (TAS 475)	1-4
Nominal Traits	1-5
Warranted Characteristics	1-9
Performance Conditions	1-9
Typical Characteristics	1-17

Operation

Power On	2-1
Installation	2-1
Quick Start	2-3
Selecting and Deselecting Input Channels	2-3
Using the Menus	2-3
Connecting a Signal	2-4
Using AUTOSET	2-4

Compensating the Probe	2-5
Menu Map	2-8

Theory of Operation

Circuit Description	3-1
Logic Conventions	3-1
Module Interconnection	3-1
Analog Board	3-4
Attenuators A1	3-4
Probe Coding Interface A1	3-4
Analog Acquisition Hybrid A1	3-4
Processor System	3-4
Processor Subsystem A5	3-4
ROM/RAM Subsystem A5	3-5
Readout Subsystem A5	3-5
Front-Panel Interface Subsystem A5	3-5
Analog Board Interface Subsystem A5	3-5
Display Assembly	3-5
Vertical Output A3	3-6
Horizontal Output A3	3-6
High Voltage A3	3-6
Front Panel	3-6
Menu Switches A4	3-6
CPU A4	3-7
FPP Pots & Probes A4	3-7
LEDs & Driver A4	3-7
Switches A4	3-8
Low Voltage Power Supply	3-8
Fan	3-8

Performance Verification

General Instructions	4-1
Using the Brief Performance Checks Procedures	4-1
Using the Performance Tests Procedures	4-1
Conventions	4-2
Brief Performance Checks	4-3
Power-On Self Tests	4-3
Functional Tests	4-3
Functional Tests Prerequisites	4-4
Verify the Probe Compensator Output	4-4
Verify the Input Channels	4-5
Verify the Alt/Chop and Add Functions	4-6

Verify the Time Base	4-7
Verify the Trigger System	4-8
Temperature Compensation Calibrations	4-9
Horizontal Sweep Path	4-9
Vertical Signal Path	4-12
Performance Tests	4-13
Performance Tests Prerequisites	4-13
Equipment Required	4-13
Vertical System Checks	4-15
Check DC Gain and Voltage Measurement Accuracy	4-15
Check Trigger Level Accuracy	4-16
Check DC Coupling Bandwidth	4-17
Check X-Axis Gain	4-19
Horizontal System Checks	4-19
Check Time Base and Time Cursor Accuracy	4-19
Check Dual Delay Accuracy	4-23
Trigger System Checks	4-25
Check Trigger Sensitivity	4-25

Adjustment

Adjustment Procedures	5-1
Requirements for Performance	5-1
Personnel	5-1
Access to Adjustments	5-1
Warm-Up Period	5-1
Equipment Required	5-2
Performing the Adjustment Procedures	5-2
Complete Adjustment	5-3
Partial Adjustment	5-3
Adjustment Dependencies	5-3
Adjustment Instructions	5-4
CRT Adjustments	5-4
Low Frequency Output Compensation	5-5
Factory Horizontal Cal	5-7
Factory Vertical Cal	5-10
High Frequency Step Response	5-12
Attenuator Compensation	5-14
Vertical Gain Adjust (Cabinet On)	5-16

Maintenance

Maintenance Information	6-1
Before Servicing	6-1
Tektronix Service	6-1
Warranty Service	6-1
Repair or Calibration Service	6-2
Self Service	6-2
Preventing ESD	6-2
Susceptibility to ESD	6-3
Inspection and Cleaning	6-5
General Care	6-5
Inspection and Cleaning Procedures	6-5
Inspection — Exterior	6-6
Cleaning Procedure — Exterior	6-6
Cleaning Procedure — Interior	6-7
Cleaning the CRT Implosion Shield	6-7
Removal and Installation Procedures	6-9
Preparation — Please Read	6-9
Cable Removal	6-9
General Instructions	6-10
Summary of Procedures	6-10
Line Cord and Line Fuse	6-14
Line Cord	6-14
Line Fuse	6-15
Front-Panel Knobs and Shafts	6-15
Removing Front-Panel Knobs and Shafts	6-15
Installing Front-Panel Knobs and Shafts	6-16
Feet, Rear Cover, and Cabinet	6-17
Rear Cover	6-18
Cabinet	6-18
Replacing the Front Feet	6-18
Front-Panel Trim, Menu and Power Buttons, EMI Gasket	6-18
Removing the Front Trim	6-18
Menu Buttons and Elastomer	6-19
Power Button Replacement	6-19
Installing the Front Trim	6-19
Installing the EMI Gaskets (TAS 485 Only)	6-20
A62 Front Panel module Removal	6-21
Front-Panel Module Disassembly/Assembly	6-22
Menu Flex Circuit Replacement	6-24
A1 Analog Board	6-26
CRT Implosion Shield	6-27
CRT	6-29
CRT Removal	6-29
CRT Installation	6-31

CRT Light Guide	6-32
CRT Front Bracket	6-33
A2 Display Control Board	6-33
A63 Power Supply Module	6-34
Power Supply Removal	6-34
Power Supply Installation	6-35
Fan and Fan Mount	6-36
Fan and Fan Mount Removal	6-36
Fan and Fan Mount Installation	6-37
Troubleshooting	6-39
Troubleshooting Procedure	6-39
Equipment	6-39
Symptom Matrix	6-40
Repackaging Information	6-49

Options

Options	7-1
Options A1–A5: International Power Cords	7-1
Warranty-Plus Service Options	7-1
Option 3R: Rackmount	7-1
Option 02: Front Cover and Pouch	7-2
Option 9C: Certificate of Calibration and Test Data Report ..	7-2

Replaceable Electrical Parts List

Replaceable Electrical Parts	8-1
-------------------------------------------	------------

Diagrams

Diagrams and Circuit Board Illustrations	9-1
Symbols	9-1
Component Values	9-1
Graphic Items and Special Symbols Used in This Manual ...	9-1
Component Locator Diagrams	9-2

Replaceable Mechanical Parts List

Replaceable Mechanical Parts	10-1
-------------------------------------------	-------------



List of Figures

Figure 2-1: Rear Panel	2-1
Figure 2-2: Fuse Compartment	2-2
Figure 2-3: POWER Button	2-2
Figure 2-4: Probe Compensation Signal Displayed after AUTOSSET ..	2-5
Figure 2-5: Connections for Compensating a Probe	2-5
Figure 2-6: How Probe Compensation Affects Signals	2-7
Figure 2-7: Location of Probe Head Adjustment	2-7
Figure 2-8: Menu Map	2-8
Figure 3-1: Block Diagram	3-2
Figure 4-1: Graticule References	4-2
Figure 4-2: Test Hookup for Functional Tests	4-4
Figure 4-3: Horizontal Adjustments (One)	4-10
Figure 4-4: Horizontal Adjustments (Two)	4-11
Figure 4-5: Horizontal Adjustments (Three)	4-11
Figure 4-6: Gain and Voltage Test Setup	4-15
Figure 4-7: Trigger Level Test Setup	4-17
Figure 4-8: Bandwidth Test Setup	4-18
Figure 4-9: X-Axis Gain Test Setup	4-19
Figure 4-10: Timing Test Setup	4-20
Figure 4-11: Dual Delay Test Setup	4-23
Figure 4-12: Trigger Sensitivity Test Setup One	4-25
Figure 4-13: Trigger Sensitivity Test Setup Two	4-26
Figure 4-14: Trigger Sensitivity Test Setup Three	4-27
Figure 4-15: Video Trigger Test Setup	4-28
Figure 5-1: Location of Boards for Adjustments	5-2
Figure 5-2: CRT Adjustments Calibration Setup	5-5
Figure 5-3: Low Frequency Output Compensation Calibration Setup	5-6
Figure 5-4: Horizontal Adjustments	5-7
Figure 5-5: Horizontal Adjustments	5-8
Figure 5-6: Horizontal Adjustments	5-8
Figure 5-7: Horizontal Output Calibration Setup	5-9
Figure 5-8: Factory Vertical Calibration Setup	5-10
Figure 5-9: Vertical Adjustments	5-11
Figure 5-10: Adjusting Vertical Gain and Centering	5-12
Figure 5-11: High Frequency Step Response Test Setup	5-12
Figure 5-12: Attenuator Compensation Test Setup	5-14
Figure 5-13: TAS 485 Vertical Termination Hybrid Adjustment	5-17
Figure 5-14: TAS 475 Display Driver Board Adjustment Locations ..	5-18
Figure 5-15: TAS 485 Display Driver Board Adjustment Locations ..	5-19

Figure 5-16: Analog Board Adjustment Locations	5-20
Figure 6-1: Oscilloscope Orientation	6-10
Figure 6-2: Cabinet and Front-Panel Mounted Modules	6-12
Figure 6-3: Internal Modules	6-13
Figure 6-4: Cables and Cable Routing	6-14
Figure 6-5: Line Fuse and Line Cord Removal	6-15
Figure 6-6: Knob and Shaft Removal	6-16
Figure 6-7: Rear Cover, Cabinet, and Feet Removal	6-17
Figure 6-8: Trim Ring and Menu Buttons Removal	6-20
Figure 6-9: EMI Gasket Installation	6-21
Figure 6-10: A62 Front Panel Module Removal	6-22
Figure 6-11: Disassembly of Front-Panel Assembly	6-23
Figure 6-12: Front-Panel Ground Spring	6-24
Figure 6-13: Menu Flex Circuit Board Removal	6-25
Figure 6-14: A1 Analog Board Removal	6-27
Figure 6-15: CRT Implosion Shield Removal	6-28
Figure 6-16: CRT Rear Bracket and Ground Clip	6-30
Figure 6-17: CRT Removal	6-32
Figure 6-18: Power Button Shaft Disconnect	6-34
Figure 6-19: Power Supply Removal	6-35
Figure 6-20: Fan and Fan Mount Removal	6-37
Figure 6-21: A5 CPU Board Troubleshooting Procedure	6-42
Figure 6-22: A1 Analog Board Troubleshooting Procedure	6-43
Figure 6-22: A1 Analog Board Troubleshooting Procedure (Cont.) ..	6-44
Figure 6-23: A3 Display Driver Board Troubleshooting Procedure ..	6-45
Figure 6-23: A3 Display Driver Board Troubleshooting Procedure (Cont.)	6-46
Figure 6-24: A62 Front Panel module Troubleshooting Procedure ..	6-47
Figure 6-25: A2 Display Control Board Troubleshooting Procedure ..	6-48
Figure 9-1: Graphic Items and Special Symbols Used in This Manual	9-2
Figure 9-2: Circuit Board Component Locator Diagram Key	9-2
Figure 9-3: Semiconductor Lead Configurations	9-3
Figure 9-4: Locating Components on Circuit Board or Schematic Diagram	9-4
Figure 9-5: A2 Display Control Board	9-5
Figure 9-6: A5 Processor Board TAS 475 — SN B010570 and Below TAS 485 — SN B010320 and Below	9-7
Figure 9-7: A5 Processor Board TAS 475 — SN B010571 and Above TAS 485 — SN B010321 and Above	9-9
Figure 9-8: A4 Front Panel Board	9-11
Figure 9-9: A1 Analog Board and A10 Termination Board	9-13
Figure 9-10: A3 Display Driver Board (TAS 475)	9-15
Figure 9-11: A3 Display Driver Board (TAS 485)	9-17

Figure 10-1: Cabinet and Rear	10-5
Figure 10-2: Front Panel Assembly	10-7
Figure 10-3: Chassis	10-11
Figure 10-4: Circuit Boards	10-13
Figure 10-5: Accessories	10-14

List of Figures



List of Tables

Table 1-1: Nominal Traits — Vertical Deflection System	1-5
Table 1-2: Nominal Traits — Time Base System	1-6
Table 1-3: Nominal Traits — Triggering System	1-6
Table 1-4: Nominal Traits — Video Triggering System	1-7
Table 1-5: Nominal Traits — Cursors	1-7
Table 1-6: Nominal Traits — XY Operation	1-7
Table 1-7: Nominal Traits — Setup Memory Characteristics	1-7
Table 1-8: Nominal Traits — Power Fuse	1-7
Table 1-9: Nominal Traits — Mechanical	1-8
Table 1-10: Warranted Characteristics — Vertical Deflection System	1-9
Table 1-11: Warranted Characteristics — Time Base System	1-11
Table 1-12: Warranted Characteristics — Triggering System	1-13
Table 1-13: Warranted Characteristics — Video Triggering	1-14
Table 1-14: Warranted Characteristics — Cursors	1-14
Table 1-15: Warranted Characteristics — XY Operation	1-14
Table 1-16: Warranted Characteristics — Power Requirements	1-15
Table 1-17: Warranted Characteristics — Environmental and Safety	1-15
Table 1-18: Typical Characteristics — Vertical Deflection System	1-17
Table 1-19: Typical Characteristics — Time Base System	1-18
Table 1-20: Typical Characteristics — Triggering System	1-18
Table 1-21: Typical Characteristics — Video Triggering System	1-19
Table 1-22: Typical Characteristics — Z-Axis	1-19
Table 1-23: Typical Characteristics — Probe Compensator	1-20
Table 1-24: Typical Characteristics — Setup Memory	1-20
Table 4-1: Test Equipment	4-14
Table 4-2: DC Gain and Delta Volts Accuracy	4-16
Table 4-3: DC Coupled Bandwidth	4-18
Table 4-4: Time Base and Cursor Accuracies (Mag Off)	4-21
Table 4-5: Time Base Accuracy (Mag On)	4-22
Table 4-6: 500 μ s Dual Delay Accuracy	4-24
Table 5-1: Adjustments and Dependencies	5-3
Table 6-1: Relative Susceptibility to Static-Discharge Damage	6-3
Table 6-2: External Inspection Check List	6-6
Table 6-3: Tools Required for Module Removal	6-11
Table 6-4: Equipment Required for Troubleshooting	6-39
Table 6-5: Symptom Matrix	6-40
Table 7-1: International Power Cords	7-1



Preface

This is the Service Manual for the TAS 475 and TAS 485 Analog Oscilloscopes. This manual provides you with both service and limited operation information.

Use the *Introduction* section to learn what the TAS 475 and TAS 485 Analog Oscilloscopes can do and about the available options and accessories.

Use the *Operation* section to learn about applying power. This section also contains brief examples of how to use the controls.

Use the *Specifications* section as a reference for all nominal, warranted, and typical characteristics for the TAS 475 and TAS 485 Analog Oscilloscopes.

Use the *Theory* section to help you understand the operation of the oscilloscope to the block level.

Use the *Performance Verification* section to verify the functionality and warranted characteristics of the oscilloscope.

Use the *Adjustment* section to bring the TAS 475 and TAS 485 Analog Oscilloscopes into conformance with the warranted characteristics listed in the *Specifications* section. You should adjust the oscilloscope if indicated by the *Performance Verification* procedures.

Use the *Maintenance* section to learn how to perform general maintenance of your product. Procedures to disassemble and troubleshoot the oscilloscope are also located in this section.

Use the *Replaceable Electrical Parts List* section for a list of the electrical parts.

Use the *Diagrams* section for troubleshooting the oscilloscope. This section contains board dollies, block diagrams and schematics for each board.

Use the *Replaceable Mechanical Parts List* section for a list of the mechanical parts.

Related Manuals

Other documentation for the TAS 475 and TAS 485 Analog Oscilloscopes include:



- The *Reference* (Tektronix part number 070–8720–00) gives you a quick overview of how to operate your TAS 400 Series Analog Oscilloscopes.
- The *Instruction* manual (Tektronix part number 070–8688–01) contains detailed operating information and limited service information.
- The *XYZs of Analog and Digital Oscilloscopes* (Tektronix part number 070–8690–01) provides you with a basic understanding of oscilloscopes and their use.

Safety Summary

Please take a moment to review these safety precautions. They are provided for your protection and to prevent damage to the oscilloscope. This safety information applies to all operators and service personnel.

Symbols and Terms

These two terms appear in manuals:

-  statements identify conditions or practices that could result in damage to the equipment or other property.
-  statements identify conditions or practices that could result in personal injury or loss of life.

These two terms appear on equipment:

- *CAUTION* indicates a personal injury hazard not immediately accessible as one reads the marking, or a hazard to property including the equipment itself.
- *DANGER* indicates a personal injury hazard immediately accessible as one reads the marking.

This symbol appears in manuals:



Static-Sensitive Devices

These symbols appear on equipment:



DANGER
High Voltage



Protective
ground (earth)
terminal



ATTENTION
Refer to
manual

Specific Precautions

Observe all of the following precautions to ensure your personal safety and to prevent damage to either the TAS 475 and TAS 485 Analog Oscilloscopes or equipment connected to them.

Do Not Perform Service While Alone

Do not perform internal service or adjustment of this product unless another person capable of rendering first aid and resuscitation is present.

Use Care When Servicing With Power On

Dangerous voltages exist at several points in this product. To avoid personal injury, do not touch exposed connections or components while power is on. Disconnect power before removing protective panels, soldering, or replacing components.

Power Source

The TAS 475 and TAS 485 Analog Oscilloscopes are intended to operate from a power source that will not apply more than 250 V_{RMS} between the supply conductors or between either supply conductor and ground. A protective ground connection, through the grounding conductor in the power cord, is essential for safe system operation.

Grounding the Oscilloscope

The TAS 475 and TAS 485 Analog Oscilloscopes are grounded through the power cord. To avoid electric shock, plug the power cord into a properly wired receptacle where earth ground has been verified by a qualified service person. Do this before making connections to the input or output terminals of the oscilloscope.

Without the protective ground connection, all parts of the TAS 475 and TAS 485 Analog Oscilloscopes are potential shock hazards. This includes knobs and controls that may appear to be insulators.

Use the Proper Power Cord

Use only the power cord and connector specified for your product. Use only a power cord that is in good condition.

Use the Proper Fuse

To avoid fire hazard, use only the fuse specified in the parts list for your product. It must be identical in type, voltage rating, and current rating.

Do Not Remove Covers or Panels

To avoid personal injury, do not operate the TAS 475 or TAS 485 without the panels or covers.

Do Not Operate in Explosive Atmospheres

The TAS 475 or TAS 485 provide no explosion protection from static discharges or arcing components. Do not operate the TAS 475 or TAS 485 in an atmosphere of explosive gasses.

Electric Overload

Never apply a voltage to a connector on the TAS 475 or TAS 485 that is outside the range specified for that connector.

Product Description

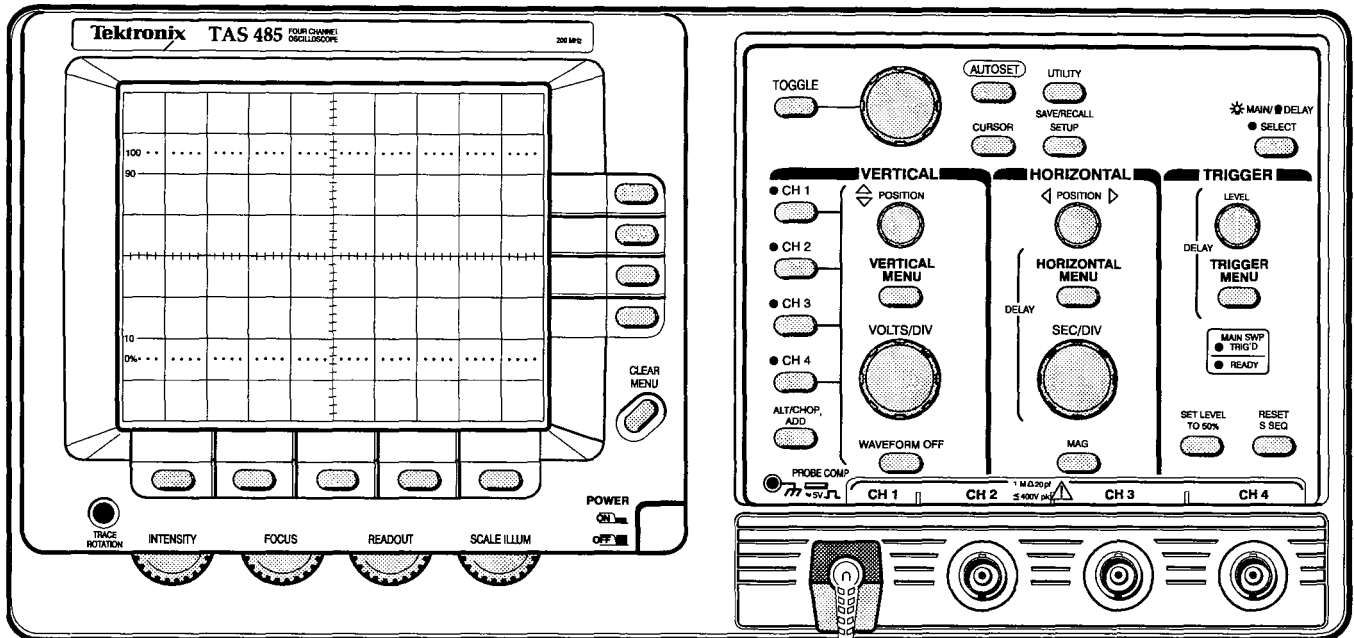

Your Tektronix TAS 475 and TAS 485 Analog Oscilloscopes are superb tools for processing and displaying electrical signals. Their performance addresses the needs of both benchtop and portable applications with the following features:

- 100 MHz minimum bandwidth (TAS 475)
200 MHz minimum bandwidth (TAS 485)
- Four-channel input
- Complete cursor measurement system
 - Voltage
 - Time
 - Frequency
- Delayed time base
- AUTOSET feature
- Front panel setup memory

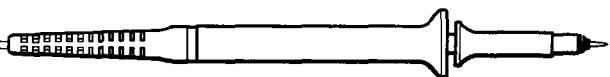

Product Description

The features of the TAS 475 and TAS 485 Analog Oscilloscopes are briefly described here to help get you acquainted with the operating systems.

User Interface

This oscilloscope uses a combination of front-panel buttons, knobs, and on-screen menus to control its many functions. The front-panel controls are grouped according to function: vertical, horizontal, trigger, and special. Within each group, any function adjusted often, such as vertical positioning or the time base setting, is set directly by its own front-panel control.

AUTOSET

The **AUTOSET** button provides you with a usable, triggered display of a signal applied to an input channel. Many instrument controls and menus are set to a pre-defined state, providing you with a known starting point for your measurements.

Menus

Those functions for which control settings changed less often, such as vertical coupling and trigger mode, are set indirectly. That is, pressing a front-panel button, such as **VERTICAL MENU**, displays a menu of functions at the bottom of the screen related to that button. (For the button **VERTICAL MENU**, the menu displayed contains functions such as coupling and bandwidth.) The buttons below this main menu select a function, such as coupling and displays a sub menu of settings for that function, such as DC, AC, or GND, at the right side of the screen. The buttons to the right of the menu select a setting, such as DC.

General Purpose Knob and TOGGLE

Some menus assign the General Purpose Knob to a selected adjustment. The method employed is the same as for *selecting* a function, except the final selection in the side menu causes the General Purpose Knob to *adjust* some function, such as the position of measurement cursors on screen. Pressing the **CLEAR MENU** button clears the assignment of the General Purpose Knob except when assigned to adjust cursors or delay time.

The **TOGGLE** button works in conjunction with the General Purpose Knob when positioning cursors. Each press of the **TOGGLE** button switches which cursor is active, and therefore controlled by the General Purpose Knob.

Save/Recall Setups

You can store up to four complete front panel setups in memory. Once you complete a complex setup and then save it in one of the four memory locations, you can retrieve it at any time. Saved front panel settings do not include the assignment of the General Purpose Knob.

Vertical System

The vertical system provides four vertical channels with calibrated vertical scale factors from 2 mV to 5 V per division.

All channels can be displayed, vertically positioned, bandwidth limited (to either Full or 20 MHz), inverted, and vertical coupling specified.

Besides the four channels, math waveforms are available for display. (A math waveform results when you add two channels.)

Horizontal System

There are three horizontal display modes: main, delayed, and XY.

The main display is the standard horizontal display mode with calibrated sec/div scales.

The delayed display can be delayed by time with respect to the main trigger. The delayed display can also be set to display at the first valid trigger after the delay. The delayed display also has a calibrated sec/div scale.

XY mode is useful to measure the phase difference of two signals.

Trigger System

The triggering system comprises a complete set of features for triggering the horizontal system. You can configure trigger for source, slope, coupling, mode, and holdoff. Video triggers are available for triggering on video signals.

You can adjust the trigger level or automatically set it to 50% of the trigger signal with the press of a button.

Measurement Cursors

Once you have set up to take your measurements, the cursors can help you take those measurements quickly.

The TAS 475 and TAS 485 Oscilloscopes have two types of cursors for taking measurements on the displayed waveforms: delta (difference) and absolute. The General Purpose Knob controls the placement of the cursors. The **TOGGLE** button selects which cursor is active.

Delta voltage measures the voltage between the horizontal bar cursors. Delta time measures the time between vertical bar cursors. These are delta measurements; that is, measurements based on the difference between two cursors.

Absolute voltage measures the voltage position of a single horizontal bar cursor. The displayed voltage level readout is made with respect to the ground reference level of the channel.

Product Description

The bar cursors remain displayed even if you change the function of the General Purpose Knob. This allows you to use them as reference points or markers to easily identify if measurement signals remain within the parameters set by the cursors. Remove the cursor display by turning the cursor measurement off.

Option 22: Additional Probes

With this option, Tektronix ships two additional probes identical to the two standard-accessory probes normally shipped with the instrument (P6109B for the TAS 475 and P6111B for the TAS 485). This provides one probe for each front-panel input.

Option 23: Additional Probes — (TAS 475)

Probes (quantity two), 10X Passive; 100 MHz (TAS 475)	P6109B (single unit)
Probes (quantity two), 10X Passive; 200 MHz (TAS 485)	P6111B (single unit)
P6109B Probe Manual (TAS 475)	070-7849-01
P6111B Probe Manual (TAS 485)	070-8543-00

Nominal Traits

This subsection contains a collection of tables that list the various *nominal traits* that describe the TAS 475 and TAS 485 Analog Oscilloscopes. Included are electrical and mechanical traits.

Nominal traits are described using simple statements of fact such as “Four, all identical” for the trait “Number of Input Channels,” rather than in terms of limits that are performance requirements.

Table 1-1: Nominal Traits — Vertical Deflection System

Name	Description
Number of Input Channels	Four, all identical, called CH 1, CH 2, CH 3, and CH 4.
Input Coupling	DC, AC, or GND. GND input coupling disconnects the input connector from the attenuator and connects a ground reference to the input of the attenuator.
Sensitivity Range	2 mV/div to 5 V/div. The sensitivity ranges from 2 mV/div to 5 V/div in a 1–2–5 sequence.
Trace Separation Control Range	$\geq \pm 4$ divisions.
Bandwidth Selections	20 MHz and FULL, selected independently for each channel.
TAS 475 Rise Time	≤ 3.5 ns. Nominal rise times are calculated from the following formula: $\text{Rise Time (ns)} = \frac{350}{\text{BW (MHz)}}$
TAS 485 Rise Time	≤ 1.75 ns. Nominal rise times are calculated from the following formula: $\text{Rise Time (ns)} = \frac{350}{\text{BW (MHz)}}$
Vertical Position Range	$\geq \pm 10$ divisions from graticule center.
TekProbe Interface	Detects 1X, 10X, and 100X attenuator probes.

Nominal Traits

Table 1-2: Nominal Traits — Time Base System

Name	Description
TAS 475 Main Seconds/Division Range	20 ns/div to 0.5 s/div. The seconds/division ranges from 20 ns/div to 0.5 s/div in a 1–2–5 sequence of settings. The X10 magnifier extends the maximum sweep speed to 2 ns/div.
TAS 485 Main Seconds/Division Range	10 ns/div to 0.5 s/div. The seconds/division ranges from 10 ns/div to 0.5 s/div in a 1–2–5 sequence of settings. The X10 magnifier extends the maximum sweep speed to 1 ns/div.
TAS 475 Delayed Seconds/Division Range	20 ns/div to 5 ms/div. The seconds/division ranges from 20 ns/div to 5 ms/div in a 1–2–5 sequence of settings. The X10 magnifier extends the maximum sweep speed to 2 ns/div.
TAS 485 Delayed Seconds/Division Range	10 ns/div to 5 ms/div. The seconds/division ranges from 10 ns/div to 5 ms/div in a 1–2–5 sequence of settings. The X10 magnifier extends the maximum sweep speed to 1 ns/div.
Sweep Length	> 10 divisions.
Delay Control Range	0.15 division to 10 times the Main seconds/division setting. The maximum value can not exceed the end of the Main sweep.
Delta Time Control Range	0 to 10 divisions to the right of setting of the delay control, but maximum value does not exceed end of the Main sweep.

Table 1-3: Nominal Traits — Triggering System

Name	Description						
Trigger Level or Threshold Ranges	The ranges are as follows:						
	<table border="1"> <thead> <tr> <th>Source</th> <th>Range</th> </tr> </thead> <tbody> <tr> <td>Internal</td> <td>± 15 divisions from center of screen with ground at center graticule.</td> </tr> <tr> <td>Line</td> <td>± 400 V.</td> </tr> </tbody> </table>	Source	Range	Internal	± 15 divisions from center of screen with ground at center graticule.	Line	± 400 V.
Source	Range						
Internal	± 15 divisions from center of screen with ground at center graticule.						
Line	± 400 V.						

Table 1-4: Nominal Traits — Video Triggering System

Name	Description
Slope Selection	Slope selection must match the polarity of the sync (i.e., for negative going sync, negative slope must be selected). A default slope selection for TV trigger modes can be entered in the scope configuration menu.

Table 1-5: Nominal Traits — Cursors

Name	Description
Cursor Functions	Δ Time, $1/\Delta$ Time, Absolute Volts, Δ Volts, Track Trig Level, Ground.

Table 1-6: Nominal Traits — XY Operation

Name	Description
Sensitivity Range	Same as Vertical Deflection System. Volts/div variables in calibrated settings.

Table 1-7: Nominal Traits — Setup Memory Characteristics

Name	Description
Nonvolatile Setup Memory	4 Setups.

Table 1-8: Nominal Traits — Power Fuse

Name	Description									
Fuse Rating	Either of two fuses may be used. Fuse types are as follows:									
	<table border="1"> <thead> <tr> <th><i>Voltage Range</i></th> <th><i>Fuse (250 V) UL 198.6 (5 × 20 mm)</i></th> <th><i>Fuse (250 V) IEC 127 (5 × 20 mm)</i></th> </tr> </thead> <tbody> <tr> <td>90 — 132 VAC</td> <td>3 A Fast.</td> <td>3.15 A Fast.</td> </tr> <tr> <td>180 — 250 VAC</td> <td>3 A Fast.</td> <td>1.5 A Fast.</td> </tr> </tbody> </table>	<i>Voltage Range</i>	<i>Fuse (250 V) UL 198.6 (5 × 20 mm)</i>	<i>Fuse (250 V) IEC 127 (5 × 20 mm)</i>	90 — 132 VAC	3 A Fast.	3.15 A Fast.	180 — 250 VAC	3 A Fast.	1.5 A Fast.
<i>Voltage Range</i>	<i>Fuse (250 V) UL 198.6 (5 × 20 mm)</i>	<i>Fuse (250 V) IEC 127 (5 × 20 mm)</i>								
90 — 132 VAC	3 A Fast.	3.15 A Fast.								
180 — 250 VAC	3 A Fast.	1.5 A Fast.								

Nominal Traits

Table 1-9: Nominal Traits — Mechanical

Name	Description
Weight	Weights that follow are nominal: <ul style="list-style-type: none"> ■ 7.7 kg (17 lbs.), stand-alone instrument. ■ 9.3 kg (20.5 lbs.), with front cover, accessories and accessories pouch installed. ■ 13.6 kg (30 lbs.), when packaged for domestic shipment.
Overall Dimensions	Dimensions that follow are nominal: <p>Height:</p> <ul style="list-style-type: none"> ■ 191 mm (7.5 in.), when feet and accessories pouch are installed. ■ 165 mm (6.5 in.), without the accessories pouch installed. <p>Width:</p> <ul style="list-style-type: none"> ■ 362 mm (14.25 in.), with handle. <p>Depth:</p> <ul style="list-style-type: none"> ■ 471 mm (18.55 in.), stand-alone instrument. ■ 490 mm (19.28 in.), with optional front cover installed. ■ 564 mm (22.20 in.), with fully handle extended.
Cooling Method	Forced-air circulation with no air filter.
Finish Type	Tektronix Blue textured paint finish on an aluminum cabinet.
Construction Material	Chassis parts constructed of aluminum alloy; front panel constructed of plastic laminate; circuit boards constructed of glass-laminate. Tektronix Blue textured paint finish on an aluminum cabinet. Plastic parts are polycarbonate.
Weight of rackmounted instrument and the rackmount conversion kit	Weights that follow are nominal: <ul style="list-style-type: none"> ■ 4.5 kg (10 lbs.), for the rackmount conversion kit only; 7.9 kg (17.5 lbs.), when kit is packaged for domestic shipping. ■ 7.3 kg (16 lbs.) plus weight of rackmount Parts, for the rack-mounted instrument (option 3R). ■ 15.4 kg (34 lbs.), when the rackmounted instrument is packaged for domestic shipment (no manuals tray).
Overall Dimensions of the rackmount instrument	Dimensions that follow are nominal: <ul style="list-style-type: none"> ■ Height: 178 mm (7 in.). ■ Width: 483 mm (19 in.). ■ Depth: 472 mm (18.6 in.). Including handles: 517 mm (20.35 in.).

Warranted Characteristics

This subsection lists the various *warranted characteristics* that describe the TAS 475 and TAS 485 Analog Oscilloscopes. Included are electrical and environmental characteristics.

Warranted characteristics are described in terms of quantifiable performance limits which are warranted. This subsection lists only warranted characteristics. A list of *typical characteristics* starts on page 1-17.

NOTE

*In these tables, those warranted characteristics that are checked in the Performance Verification procedure, found in Section 4, appear in **boldface type** under the column **Name**.*

Performance Conditions

The electrical characteristics found in these tables of warranted characteristics apply under the following conditions:

- The oscilloscope has been adjusted at an ambient temperature between +20° C and +30° C
- A warm-up period of at least 20 minutes has occurred
- The operating temperature is between -10° C and +55° C (unless otherwise noted)
- The Temperature Compensation Calibrations (signal path compensation) have been performed

Table 1-10: Warranted Characteristics — Vertical Deflection System

Name	Description	
Input Impedance, DC Coupled	1 M Ω \pm 1% in parallel with 20 pF \pm 2.0 pF.	
Variable Range	Increases deflection factor by \geq 2.5:1.	
DC Gain Accuracy	The limits are as follows:	
	<i>Condition</i>	<i>Accuracy</i>
	+15° C to +35° C	\pm 2.5% over the center 5 divisions after signal path compensation.
	-10° C to +15° C and +35° C to +55° C	\pm 3.5% over the center 5 divisions after signal path compensation.

Warranted Characteristics

Table 1-10: Warranted Characteristics — Vertical Deflection System (Cont.)

Name	Description												
TAS 475 Bandwidth at the BNC input	100 MHz.												
TAS 485 Bandwidth at the BNC input	The limits are as follows:												
	<table border="1"> <thead> <tr> <th>Condition</th> <th>Bandwidth</th> </tr> </thead> <tbody> <tr> <td>-10° C to +35° C</td> <td></td> </tr> <tr> <td>5 mV/div to 5 V/div ranges</td> <td>200 MHz.</td> </tr> <tr> <td>2 mV/div range</td> <td>180 MHz.</td> </tr> <tr> <td>+35° C to +55° C</td> <td></td> </tr> <tr> <td>All ranges</td> <td>Subtract 1 MHz/°C above +35° C.</td> </tr> </tbody> </table>	Condition	Bandwidth	-10° C to +35° C		5 mV/div to 5 V/div ranges	200 MHz.	2 mV/div range	180 MHz.	+35° C to +55° C		All ranges	Subtract 1 MHz/°C above +35° C.
Condition	Bandwidth												
-10° C to +35° C													
5 mV/div to 5 V/div ranges	200 MHz.												
2 mV/div range	180 MHz.												
+35° C to +55° C													
All ranges	Subtract 1 MHz/°C above +35° C.												
TAS 475 Bandwidth at the probe tip, using the Standard-Accessory Probe	The limits are as follows:												
	<table border="1"> <thead> <tr> <th>Condition</th> <th>Bandwidth</th> </tr> </thead> <tbody> <tr> <td>+15° C to +35° C</td> <td>100 MHz.</td> </tr> <tr> <td>-10° C to +15° C and +35° C to +55° C</td> <td>90 MHz.</td> </tr> </tbody> </table>	Condition	Bandwidth	+15° C to +35° C	100 MHz.	-10° C to +15° C and +35° C to +55° C	90 MHz.						
Condition	Bandwidth												
+15° C to +35° C	100 MHz.												
-10° C to +15° C and +35° C to +55° C	90 MHz.												
TAS 485 Bandwidth at the probe tip, using the Standard-Accessory Probe	The limits are as follows:												
	<table border="1"> <thead> <tr> <th>Condition</th> <th>Bandwidth</th> </tr> </thead> <tbody> <tr> <td>+15° C to +35° C</td> <td>200 MHz.</td> </tr> <tr> <td>-10° C to +15° C and +35° C to +55° C</td> <td>180 MHz.</td> </tr> </tbody> </table>	Condition	Bandwidth	+15° C to +35° C	200 MHz.	-10° C to +15° C and +35° C to +55° C	180 MHz.						
Condition	Bandwidth												
+15° C to +35° C	200 MHz.												
-10° C to +15° C and +35° C to +55° C	180 MHz.												
Lower Frequency Limit, AC Coupled	<p>≤ 10 Hz with 1X probe.</p> <p>The AC Coupled Lower Frequency Limits are reduced by a factor of 10 when 10X, passive probes are used.</p>												
TAS 475 Crosstalk (Channel Isolation)	≥ 50 dB at 10 MHz, ≥ 35 dB at 100 MHz.												
TAS 485 Crosstalk (Channel Isolation)	≥ 50 dB at 10 MHz, ≥ 32 dB at 200 MHz.												
Delay Between Channels, Full Bandwidth	≤ 200 ps between any two channels with equal volts/div and coupling settings.												
Common-mode Rejection Ratio (CMRR)	≥ 10:1 at ≤ 50 MHz.												

Table 1-10: Warranted Characteristics — Vertical Deflection System (Cont.)

Name	Description	
Trace Shift	The limits are as follows:	
	<i>Condition</i>	<i>Allowable Trace Shift</i>
	Changing volts/div settings	$< \pm(0.1 \text{ division} + 0.2 \text{ mV})$.
	Selecting invert	$\leq 0.5 \text{ division}$.
	Changing from bandwidth limit to full bandwidth	$\leq 0.1 \text{ division}$.
Maximum Input Voltage	$\pm 400 \text{ V}$ (DC + peak AC); derate at 20 dB/decade from 100 kHz to 13 V at 3 MHz.	
Low Frequency Linearity	Within $\pm 5\%$.	

Table 1-11: Warranted Characteristics — Time Base System

Name	Description	
Time Base Accuracy, Magnify Off	The limits are as follows:	
	<i>Conditions</i>	<i>Time Measurement Accuracy</i>
	+15° C to +35° C	$\pm 2\%$.
	-10° C to +15° C and +35° C to +55° C	$\pm 3\%$.
	Sweep accuracy applies over the center eight divisions. Excludes the greater of either the first $\frac{1}{4}$ division or 25 ns from the sweep start of the magnified sweep and anything beyond the 100th magnified division.	

Warranted Characteristics

Table 1-11: Warranted Characteristics — Time Base System (Cont.)

Name	Description																																							
TAS 475 Time Base Accuracy, Magnify On	The limits are as follows:																																							
	<table border="1" style="width: 100%; border-collapse: collapse;"> <thead> <tr> <th data-bbox="635 365 759 394"><i>Conditions</i></th> <th data-bbox="1050 365 1398 394"><i>Time Measurement Accuracy</i></th> </tr> </thead> <tbody> <tr> <td data-bbox="635 422 847 451">-10° C to + 55° C</td> <td data-bbox="1050 478 1123 508">±4%.</td> </tr> <tr> <td data-bbox="735 478 1011 539">Excluding 5 ns/div and 2 ns/div</td> <td data-bbox="1050 478 1123 508"></td> </tr> <tr> <td data-bbox="635 560 863 590">+15° C to + 35° C</td> <td data-bbox="1050 617 1123 646">±3%.</td> </tr> <tr> <td data-bbox="735 617 986 646">5 ns/div and 2 ns/div</td> <td data-bbox="1050 617 1123 646"></td> </tr> <tr> <td data-bbox="635 674 916 735">-10° C to + 15° C and +35° C to + 55° C</td> <td data-bbox="1050 753 1123 783">±5%.</td> </tr> <tr> <td data-bbox="735 753 986 783">5 ns/div and 2 ns/div</td> <td data-bbox="1050 753 1123 783"></td> </tr> <tr> <td colspan="2" data-bbox="635 810 1442 926">Sweep accuracy applies over the center eight divisions. Excludes the greater of either the first ¼ division or 25 ns from the sweep start of the magnified sweep and anything beyond the 100th magnified division.</td> </tr> <tr> <td data-bbox="129 953 512 1014" rowspan="5">TAS 485 Time Base Accuracy, Magnify On</td> <td data-bbox="635 953 927 982">The limits are as follows:</td> </tr> <tr> <td data-bbox="635 1005 1398 1035"> <table border="1" style="width: 100%; border-collapse: collapse;"> <thead> <tr> <th data-bbox="635 1005 759 1035"><i>Conditions</i></th> <th data-bbox="1050 1005 1398 1035"><i>Time Measurement Accuracy</i></th> </tr> </thead> <tbody> <tr> <td data-bbox="635 1062 847 1092">-10° C to + 55° C</td> <td data-bbox="1050 1119 1123 1148">±4%.</td> </tr> <tr> <td data-bbox="735 1119 1011 1180">Excluding 2 ns/div and 1 ns/div</td> <td data-bbox="1050 1119 1123 1148"></td> </tr> <tr> <td data-bbox="635 1201 863 1230">+15° C to + 35° C</td> <td data-bbox="1050 1257 1123 1287">±3%.</td> </tr> <tr> <td data-bbox="735 1257 986 1287">2 ns/div and 1 ns/div</td> <td data-bbox="1050 1257 1123 1287"></td> </tr> <tr> <td data-bbox="635 1314 916 1375">-10° C to + 15° C and +35° C to + 55° C</td> <td data-bbox="1050 1394 1123 1423">±7%.</td> </tr> <tr> <td data-bbox="735 1394 986 1423">2 ns/div and 1 ns/div</td> <td data-bbox="1050 1394 1123 1423"></td> </tr> <tr> <td colspan="2" data-bbox="635 1451 1442 1566">Sweep accuracy applies over the center eight divisions. Excludes the greater of either the first ¼ division or 25 ns from the sweep start of the magnified sweep and anything beyond the 100th magnified division.</td> </tr> <tr> <td data-bbox="129 1593 536 1623">Horizontal Position Control Range</td> <td data-bbox="635 1593 1433 1709">The position control is able to move the start of the sweep to the right of the center vertical graticule and able to move a time mark corresponding to the tenth division on an unmagnified sweep to the left of the graticule center.</td> </tr> <tr> <td data-bbox="129 1736 408 1766">Variable Control Range</td> <td data-bbox="635 1736 1433 1824">Continuously variable between calibrated seconds/division settings. Extends both the Main and Delayed sweep seconds/division settings by a factor of 2.5 times.</td> </tr> </tbody> </table> </td></tr></tbody></table>	<i>Conditions</i>	<i>Time Measurement Accuracy</i>	-10° C to + 55° C	±4%.	Excluding 5 ns/div and 2 ns/div		+15° C to + 35° C	±3%.	5 ns/div and 2 ns/div		-10° C to + 15° C and +35° C to + 55° C	±5%.	5 ns/div and 2 ns/div		Sweep accuracy applies over the center eight divisions. Excludes the greater of either the first ¼ division or 25 ns from the sweep start of the magnified sweep and anything beyond the 100th magnified division.		TAS 485 Time Base Accuracy, Magnify On	The limits are as follows:	<table border="1" style="width: 100%; border-collapse: collapse;"> <thead> <tr> <th data-bbox="635 1005 759 1035"><i>Conditions</i></th> <th data-bbox="1050 1005 1398 1035"><i>Time Measurement Accuracy</i></th> </tr> </thead> <tbody> <tr> <td data-bbox="635 1062 847 1092">-10° C to + 55° C</td> <td data-bbox="1050 1119 1123 1148">±4%.</td> </tr> <tr> <td data-bbox="735 1119 1011 1180">Excluding 2 ns/div and 1 ns/div</td> <td data-bbox="1050 1119 1123 1148"></td> </tr> <tr> <td data-bbox="635 1201 863 1230">+15° C to + 35° C</td> <td data-bbox="1050 1257 1123 1287">±3%.</td> </tr> <tr> <td data-bbox="735 1257 986 1287">2 ns/div and 1 ns/div</td> <td data-bbox="1050 1257 1123 1287"></td> </tr> <tr> <td data-bbox="635 1314 916 1375">-10° C to + 15° C and +35° C to + 55° C</td> <td data-bbox="1050 1394 1123 1423">±7%.</td> </tr> <tr> <td data-bbox="735 1394 986 1423">2 ns/div and 1 ns/div</td> <td data-bbox="1050 1394 1123 1423"></td> </tr> <tr> <td colspan="2" data-bbox="635 1451 1442 1566">Sweep accuracy applies over the center eight divisions. Excludes the greater of either the first ¼ division or 25 ns from the sweep start of the magnified sweep and anything beyond the 100th magnified division.</td> </tr> <tr> <td data-bbox="129 1593 536 1623">Horizontal Position Control Range</td> <td data-bbox="635 1593 1433 1709">The position control is able to move the start of the sweep to the right of the center vertical graticule and able to move a time mark corresponding to the tenth division on an unmagnified sweep to the left of the graticule center.</td> </tr> <tr> <td data-bbox="129 1736 408 1766">Variable Control Range</td> <td data-bbox="635 1736 1433 1824">Continuously variable between calibrated seconds/division settings. Extends both the Main and Delayed sweep seconds/division settings by a factor of 2.5 times.</td> </tr> </tbody> </table>	<i>Conditions</i>	<i>Time Measurement Accuracy</i>	-10° C to + 55° C	±4%.	Excluding 2 ns/div and 1 ns/div		+15° C to + 35° C	±3%.	2 ns/div and 1 ns/div		-10° C to + 15° C and +35° C to + 55° C	±7%.	2 ns/div and 1 ns/div		Sweep accuracy applies over the center eight divisions. Excludes the greater of either the first ¼ division or 25 ns from the sweep start of the magnified sweep and anything beyond the 100th magnified division.		Horizontal Position Control Range	The position control is able to move the start of the sweep to the right of the center vertical graticule and able to move a time mark corresponding to the tenth division on an unmagnified sweep to the left of the graticule center.	Variable Control Range	Continuously variable between calibrated seconds/division settings. Extends both the Main and Delayed sweep seconds/division settings by a factor of 2.5 times.
	<i>Conditions</i>	<i>Time Measurement Accuracy</i>																																						
	-10° C to + 55° C	±4%.																																						
	Excluding 5 ns/div and 2 ns/div																																							
+15° C to + 35° C	±3%.																																							
5 ns/div and 2 ns/div																																								
-10° C to + 15° C and +35° C to + 55° C	±5%.																																							
5 ns/div and 2 ns/div																																								
Sweep accuracy applies over the center eight divisions. Excludes the greater of either the first ¼ division or 25 ns from the sweep start of the magnified sweep and anything beyond the 100th magnified division.																																								
TAS 485 Time Base Accuracy, Magnify On	The limits are as follows:																																							
	<table border="1" style="width: 100%; border-collapse: collapse;"> <thead> <tr> <th data-bbox="635 1005 759 1035"><i>Conditions</i></th> <th data-bbox="1050 1005 1398 1035"><i>Time Measurement Accuracy</i></th> </tr> </thead> <tbody> <tr> <td data-bbox="635 1062 847 1092">-10° C to + 55° C</td> <td data-bbox="1050 1119 1123 1148">±4%.</td> </tr> <tr> <td data-bbox="735 1119 1011 1180">Excluding 2 ns/div and 1 ns/div</td> <td data-bbox="1050 1119 1123 1148"></td> </tr> <tr> <td data-bbox="635 1201 863 1230">+15° C to + 35° C</td> <td data-bbox="1050 1257 1123 1287">±3%.</td> </tr> <tr> <td data-bbox="735 1257 986 1287">2 ns/div and 1 ns/div</td> <td data-bbox="1050 1257 1123 1287"></td> </tr> <tr> <td data-bbox="635 1314 916 1375">-10° C to + 15° C and +35° C to + 55° C</td> <td data-bbox="1050 1394 1123 1423">±7%.</td> </tr> <tr> <td data-bbox="735 1394 986 1423">2 ns/div and 1 ns/div</td> <td data-bbox="1050 1394 1123 1423"></td> </tr> <tr> <td colspan="2" data-bbox="635 1451 1442 1566">Sweep accuracy applies over the center eight divisions. Excludes the greater of either the first ¼ division or 25 ns from the sweep start of the magnified sweep and anything beyond the 100th magnified division.</td> </tr> <tr> <td data-bbox="129 1593 536 1623">Horizontal Position Control Range</td> <td data-bbox="635 1593 1433 1709">The position control is able to move the start of the sweep to the right of the center vertical graticule and able to move a time mark corresponding to the tenth division on an unmagnified sweep to the left of the graticule center.</td> </tr> <tr> <td data-bbox="129 1736 408 1766">Variable Control Range</td> <td data-bbox="635 1736 1433 1824">Continuously variable between calibrated seconds/division settings. Extends both the Main and Delayed sweep seconds/division settings by a factor of 2.5 times.</td> </tr> </tbody> </table>	<i>Conditions</i>	<i>Time Measurement Accuracy</i>	-10° C to + 55° C	±4%.	Excluding 2 ns/div and 1 ns/div		+15° C to + 35° C	±3%.	2 ns/div and 1 ns/div		-10° C to + 15° C and +35° C to + 55° C	±7%.	2 ns/div and 1 ns/div		Sweep accuracy applies over the center eight divisions. Excludes the greater of either the first ¼ division or 25 ns from the sweep start of the magnified sweep and anything beyond the 100th magnified division.		Horizontal Position Control Range	The position control is able to move the start of the sweep to the right of the center vertical graticule and able to move a time mark corresponding to the tenth division on an unmagnified sweep to the left of the graticule center.	Variable Control Range	Continuously variable between calibrated seconds/division settings. Extends both the Main and Delayed sweep seconds/division settings by a factor of 2.5 times.																			
	<i>Conditions</i>	<i>Time Measurement Accuracy</i>																																						
	-10° C to + 55° C	±4%.																																						
	Excluding 2 ns/div and 1 ns/div																																							
+15° C to + 35° C	±3%.																																							
2 ns/div and 1 ns/div																																								
-10° C to + 15° C and +35° C to + 55° C	±7%.																																							
2 ns/div and 1 ns/div																																								
Sweep accuracy applies over the center eight divisions. Excludes the greater of either the first ¼ division or 25 ns from the sweep start of the magnified sweep and anything beyond the 100th magnified division.																																								
Horizontal Position Control Range	The position control is able to move the start of the sweep to the right of the center vertical graticule and able to move a time mark corresponding to the tenth division on an unmagnified sweep to the left of the graticule center.																																							
Variable Control Range	Continuously variable between calibrated seconds/division settings. Extends both the Main and Delayed sweep seconds/division settings by a factor of 2.5 times.																																							

Table 1-11: Warranted Characteristics — Time Base System (Cont.)

Name	Description
Delay Accuracy, Main Sweep Trigger Point to Start of Delayed Sweep	$\pm(0.5\% \text{ of reading} + 5\% \text{ of 1 division of the Main sweep} + 25 \text{ ns})$.
Delta Delay Accuracy	$\pm(0.5\% \text{ of reading} + 5\% \text{ of 1 division of the Main sweep} + 10 \text{ ns})$.

Table 1-12: Warranted Characteristics — Triggering System

Name	Description
TAS 475 Edge-Type Trigger Sensitivity, DC Coupled	The limits are as follows:
	<i>Trigger Source</i> <i>Sensitivity</i>
	Any Channel 0.30 division from DC to 25 MHz, increasing to 1 div at 150 MHz.
TAS 485 Edge-Type Trigger Sensitivity, DC Coupled	The limits are as follows:
	<i>Trigger Source</i> <i>Sensitivity</i>
	Any Channel 0.30 division from DC to 25 MHz, increasing to 1.5 div at 250 MHz.
Trigger Level or Threshold Accuracy	The limits are as follows for signals having rise and fall times ≥ 20 ns:
	<i>Coupling</i> <i>Source</i> <i>Accuracy</i>
	DC All except Line $\pm(5\% \text{ of reading} + 0.4 \text{ division} + 1 \text{ mV})$.
	Noise Reject All except Line $\pm(5\% \text{ of reading} + 1.1 \text{ division} + 1 \text{ mV})$.
	HF Reject All except Line $\pm(5\% \text{ of reading} + 0.35 \text{ division} + 1 \text{ mV})$.

Warranted Characteristics

Table 1-13: Warranted Characteristics — Video Triggering

Name	Description
Sensitivity	0.75 divisions of composite sync will achieve a stable display.
60 Hz Rejection	Stable video trigger with up to 4 divisions of 60 Hz on the video signal.
Sync Offset	Stable video trigger if sync tip is ± 15 divisions, referenced to input ground.
Sync Separation	Stable trigger on positive or negative composite horizontal sync (lines) video, for all 525/60 and 625/50 video systems which include: NTSC, PAL, and SECAM.
Field Interval	Stable trigger on vertical sync interval $> 20 \mu\text{s}$.

Table 1-14: Warranted Characteristics — Cursors

Name	Description						
Δ Time Cursor to Signal Accuracy	Same as Time Base Accuracy + 0.1 division.						
$1/\Delta$ Time Accuracy	Readouts calculated using Δ Time cursor difference.						
Absolute Volts Accuracy	Accuracies are as follows:						
	<table border="1"> <thead> <tr> <th>Condition</th> <th>Accuracy</th> </tr> </thead> <tbody> <tr> <td>$-10^\circ \text{ C to } +30^\circ \text{ C}$</td> <td>$\pm(1\% \text{ of reading} + 2\% \text{ of one vertical division} + \text{HF display errors} + 0.5 \text{ mV} + \text{trace shift errors})$.</td> </tr> <tr> <td>$+30^\circ \text{ C to } +55^\circ \text{ C}$</td> <td>$\pm(1\% \text{ of reading} + 2\% \text{ of one vertical division} + \text{HF display errors} + 4 \text{ mV} + \text{trace shift errors})$.</td> </tr> </tbody> </table>	Condition	Accuracy	$-10^\circ \text{ C to } +30^\circ \text{ C}$	$\pm(1\% \text{ of reading} + 2\% \text{ of one vertical division} + \text{HF display errors} + 0.5 \text{ mV} + \text{trace shift errors})$.	$+30^\circ \text{ C to } +55^\circ \text{ C}$	$\pm(1\% \text{ of reading} + 2\% \text{ of one vertical division} + \text{HF display errors} + 4 \text{ mV} + \text{trace shift errors})$.
Condition	Accuracy						
$-10^\circ \text{ C to } +30^\circ \text{ C}$	$\pm(1\% \text{ of reading} + 2\% \text{ of one vertical division} + \text{HF display errors} + 0.5 \text{ mV} + \text{trace shift errors})$.						
$+30^\circ \text{ C to } +55^\circ \text{ C}$	$\pm(1\% \text{ of reading} + 2\% \text{ of one vertical division} + \text{HF display errors} + 4 \text{ mV} + \text{trace shift errors})$.						
Δ Volts Cursor to Signal Accuracy	$\pm(1.6\% \text{ of reading} + 2\% \text{ of one vertical division} + \text{HF display errors})$.						

Table 1-15: Warranted Characteristics — XY Operation

Name	Description
XY Accuracy	$\pm 4\%$.
X Bandwidth	DC to at least 3 MHz.
Phase Difference Between X and Y Amplifiers	$\pm 3^\circ$, DC to 150 kHz.

Table 1-16: Warranted Characteristics — Power Requirements

Name	Description
Source Voltage and Frequency	90–132 VAC _{RMS} continuous range for 48 through 440 Hz. 180–250 VAC _{RMS} continuous range for 48 through 440 Hz.
Power Consumption	≤ 85 watts (150 VA).

Table 1-17: Warranted Characteristics — Environmental and Safety

Name	Description
Third Party Certifications	This product shall conform to and be certified where appropriate according to the following requirements: <i>Certification</i>
	Underwriter's Laboratories (UL) Listed or Recognized Component, Electrical and Electronic Measuring and Testing Equipment UL 1244.
	Canadian Standards CSA Association (CSA) Category Certified Electronic Development and Test Equipment, CSA 22.2 no. 231.
	Self-Certification International Electro-Technical Commission (IEC) Self-certified by Tektronix to comply with IEC 348 recommendation.
Temperature: Operating and Nonoperating	Operating: –10° C to +55° C. Nonoperating: –51° C to +71° C.
Humidity: Operating and Nonoperating	To 95% relative humidity at or below +40° C to 75% relative humidity form +41° C to +55° C. A more sever test than stated in MIL–T–28800E, para. 4.5.5.1.1.2.
Altitude: Operating and Nonoperating	Operating: To 4572 m (15,000 ft.). Nonoperating: To 12192 m (40,000 ft.).
Random Vibration: Nonoperating	2.46 g _{RMS} , from 5 to 500 Hz, 10 minutes each axis.
Random Vibration: Operating	0.31 g _{RMS} , from 5 to 500 Hz, 10 minutes each axis.
Emissions	The instrument meets or exceeds the EMC requirements of the following standards: <ul style="list-style-type: none"> ■ VFG 243. ■ FCC Code of Federal Regulations, 47 CFR, Part 15, Subpart B, Class A.
Electrostatic Discharge Susceptibility	IEC 801–2.

Typical Characteristics

This subsection contains tables that lists the various *typical characteristics* that describe the TAS 475 and TAS 485 Analog Oscilloscopes.

Typical characteristics are described in terms of typical or average performance. Typical characteristics are not warranted.

This subsection lists only typical characteristics. A list of warranted characteristics starts on page 1-9.

Table 1-18: Typical Characteristics — Vertical Deflection System

Name	Description	
Upper-Frequency Limit, 20 MHz Bandwidth Limited	20 MHz.	
Trace Shift Leakage	The typical amount of trace shift while changing the input coupling between GND and 1 M Ω DC is as follows:	
	<i>Condition</i>	<i>Typical Trace Shift</i>
	-10° C to +35° C	<0.5 mV.
	+35° C to +55° C	<2 mV.
Variable Volts/Div Offset	0.5 division trace shift while changing the variable volts/div setting.	
Chop Mode Clock Rate	>500 kHz, <1 MHz.	
	Chop mode is allowed from 0.5 s to 10 μ s sec/div settings.	
TAS 475 Noise (measured tangentially)	■ ≤ 0.06 div at ≥ 10 mV/div (600 μ V).	
	■ ≤ 0.10 div at 5 mV/div (500 μ V).	
	■ ≤ 0.14 div at 2 mV/div (280 μ V).	
TAS 485 Noise (measured tangentially)	■ ≤ 0.06 div at ≥ 10 mV/div (600 μ V).	
	■ ≤ 0.10 div at 5 mV/div (500 μ V).	
	■ ≤ 0.15 div at 2 mV/div (300 μ V).	

Typical Characteristics

Table 1-19: Typical Characteristics — Time Base System

Name	Description
Time Base Linearity	<p>$\pm 5\%$.</p> <p>Sweep linearity applies over the center eight divisions. Excludes the greater of either the first $\frac{1}{4}$ division or 25 ns from the sweep start of the magnified sweep and anything beyond the 100th magnified division.</p>
Delay Jitter	<p>≤ 1 part in 10,000 (20,000 for 1 ms and slower) + 2 ns, peak-to-peak during a two-second time interval. Exclude the first 0.15 divisions of the Main sweep.</p>

Table 1-20: Typical Characteristics — Triggering System

Name	Description										
TAS 475 Edge-Type Trigger Sensitivity, Not DC Coupled	<p>The typical sensitivities are as follows:</p> <table border="1"> <thead> <tr> <th>Trigger Source</th> <th>Typical Signal Level for Stable Triggering</th> </tr> </thead> <tbody> <tr> <td>Noise Reject</td> <td>1.2 divisions from DC to 25 MHz, increasing to 2.2 divisions at 150 MHz. 0.5 division or less will not trigger.</td> </tr> <tr> <td>HF REJ</td> <td>0.30 division from DC to 10 kHz; attenuates signals above the upper -3 dB cut-off frequency of 50 kHz.</td> </tr> <tr> <td>LF REJ</td> <td>0.30 division from 100 kHz to 25 MHz, increasing to 1.0 division at 150 MHz; attenuates signals below the lower -3 dB cutoff frequency of 50 kHz.</td> </tr> <tr> <td>AC</td> <td>0.30 division from 350 Hz to 25 MHz, increasing to 1.0 division at 150 MHz; attenuates signals below the -3 dB cut-off frequency of 160 Hz.</td> </tr> </tbody> </table>	Trigger Source	Typical Signal Level for Stable Triggering	Noise Reject	1.2 divisions from DC to 25 MHz, increasing to 2.2 divisions at 150 MHz. 0.5 division or less will not trigger.	HF REJ	0.30 division from DC to 10 kHz; attenuates signals above the upper -3 dB cut-off frequency of 50 kHz.	LF REJ	0.30 division from 100 kHz to 25 MHz, increasing to 1.0 division at 150 MHz; attenuates signals below the lower -3 dB cutoff frequency of 50 kHz.	AC	0.30 division from 350 Hz to 25 MHz, increasing to 1.0 division at 150 MHz; attenuates signals below the -3 dB cut-off frequency of 160 Hz.
Trigger Source	Typical Signal Level for Stable Triggering										
Noise Reject	1.2 divisions from DC to 25 MHz, increasing to 2.2 divisions at 150 MHz. 0.5 division or less will not trigger.										
HF REJ	0.30 division from DC to 10 kHz; attenuates signals above the upper -3 dB cut-off frequency of 50 kHz.										
LF REJ	0.30 division from 100 kHz to 25 MHz, increasing to 1.0 division at 150 MHz; attenuates signals below the lower -3 dB cutoff frequency of 50 kHz.										
AC	0.30 division from 350 Hz to 25 MHz, increasing to 1.0 division at 150 MHz; attenuates signals below the -3 dB cut-off frequency of 160 Hz.										

Table 1-20: Typical Characteristics — Triggering System (Cont.)

Name	Description										
TAS 485 Edge-Type Trigger Sensitivity, Not DC Coupled	The typical sensitivities are as follows:										
	<table border="1"> <thead> <tr> <th><i>Trigger Source</i></th> <th><i>Typical Signal Level for Stable Triggering</i></th> </tr> </thead> <tbody> <tr> <td>Noise Reject</td> <td>1.2 divisions from DC to 25 MHz, increasing to 3.5 divisions at 250 MHz. 0.5 division or less will not trigger.</td> </tr> <tr> <td>HF REJ</td> <td>0.30 division from DC to 10 kHz; attenuates signals above the upper -3 dB cut-off frequency of 50 kHz.</td> </tr> <tr> <td>LF REJ</td> <td>0.30 division from 100 kHz to 25 MHz, increasing to 1.4 division at 250 MHz; attenuates signals below the lower -3 dB cutoff frequency of 50 kHz.</td> </tr> <tr> <td>AC</td> <td>0.30 division from 350 Hz to 25 MHz, increasing to 1.4 division at 250 MHz; attenuates signals below the -3 dB cut-off frequency of 160 Hz.</td> </tr> </tbody> </table>	<i>Trigger Source</i>	<i>Typical Signal Level for Stable Triggering</i>	Noise Reject	1.2 divisions from DC to 25 MHz, increasing to 3.5 divisions at 250 MHz. 0.5 division or less will not trigger.	HF REJ	0.30 division from DC to 10 kHz; attenuates signals above the upper -3 dB cut-off frequency of 50 kHz.	LF REJ	0.30 division from 100 kHz to 25 MHz, increasing to 1.4 division at 250 MHz; attenuates signals below the lower -3 dB cutoff frequency of 50 kHz.	AC	0.30 division from 350 Hz to 25 MHz, increasing to 1.4 division at 250 MHz; attenuates signals below the -3 dB cut-off frequency of 160 Hz.
<i>Trigger Source</i>	<i>Typical Signal Level for Stable Triggering</i>										
Noise Reject	1.2 divisions from DC to 25 MHz, increasing to 3.5 divisions at 250 MHz. 0.5 division or less will not trigger.										
HF REJ	0.30 division from DC to 10 kHz; attenuates signals above the upper -3 dB cut-off frequency of 50 kHz.										
LF REJ	0.30 division from 100 kHz to 25 MHz, increasing to 1.4 division at 250 MHz; attenuates signals below the lower -3 dB cutoff frequency of 50 kHz.										
AC	0.30 division from 350 Hz to 25 MHz, increasing to 1.4 division at 250 MHz; attenuates signals below the -3 dB cut-off frequency of 160 Hz.										
Lowest Frequency for Successful Operation of "Set Level to 50%" Function	50 Hz with 1 division.										
Holdoff Control Range	Increases Main sweep holdoff time by a factor of 10.										

Table 1-21: Typical Characteristics — Video Triggering System

Name	Description
Field Separation	Stable trigger on odd or even fields in interlaced video systems with line rates between 12 kHz and 17 kHz.

Table 1-22: Typical Characteristics — Z-Axis

Name	Description						
Sensitivity	The sensitivity is as follows:						
	<table border="1"> <thead> <tr> <th><i>Condition</i></th> <th><i>Sensitivity</i></th> </tr> </thead> <tbody> <tr> <td>DC to 2 MHz</td> <td>Positive voltage decreases intensity; +2 V blanks a maximum intensity trace.</td> </tr> <tr> <td>2 MHz to 20 MHz</td> <td>+2 V modulates a normal intensity trace. +2 V (DC to 20 MHz) blanks a 1 μA CRT beam.</td> </tr> </tbody> </table>	<i>Condition</i>	<i>Sensitivity</i>	DC to 2 MHz	Positive voltage decreases intensity; +2 V blanks a maximum intensity trace.	2 MHz to 20 MHz	+2 V modulates a normal intensity trace. +2 V (DC to 20 MHz) blanks a 1 μ A CRT beam.
<i>Condition</i>	<i>Sensitivity</i>						
DC to 2 MHz	Positive voltage decreases intensity; +2 V blanks a maximum intensity trace.						
2 MHz to 20 MHz	+2 V modulates a normal intensity trace. +2 V (DC to 20 MHz) blanks a 1 μ A CRT beam.						
Rise Time	<15 ns.						

Typical Characteristics

Table 1-22: Typical Characteristics — Z-Axis (Cont.)

Name	Description
Input Resistance	10 k Ω \pm 10%.
Maximum Input Voltage	\pm 25 V peak; 25 V _{p-p} AC at 10 kHz or less.

Table 1-23: Typical Characteristics — Probe Compensator

Name	Description
Probe Compensator Output Voltage and Frequency	The limits are as follows:
	<i>Characteristic</i> <i>Limits</i>
	Output Voltage 5 V (base-top) \pm 10% into a 1 M Ω load.
Frequency	1 kHz \pm 5%.

Table 1-24: Typical Characteristics — Setup Memory

Name	Description
Nonvolatile Memory Retention Time	<p>Internal batteries, installed at time of manufacture, have a life of \geq 10 years when operated and/or stored at an ambient temperature from 0° C to +50° C. Retention time of the nonvolatile memories is equal to the remaining life of the batteries.</p> <p>Battery life can be reduced when the instrument is stored for extended time above +50° C. Retained data may be lost when stored for extended time below 0° C.</p>

Power On

Before you begin using the TAS 475 and TAS 485 Analog Oscilloscopes, ensure proper installation.

Installation

Perform this procedure to properly install and power on the TAS 475 and TAS 485 Analog Oscilloscopes.

1. Check that you have the proper electrical connections. The TAS 475 and TAS 485 Analog Oscilloscopes require 90 to 132 VAC_{RMS} or 180 to 250 VAC_{RMS}, continuous range for 48 Hz to 440 Hz. A maximum of 85 Watts may be required.
2. Check that the Line Voltage Range switch (Figure 2-1) is at the proper setting for your power system.
3. Check the fuse to ensure it is the proper type and rating (the rear panel provides you with this information). The TAS 475 and TAS 485 Analog Oscilloscopes are shipped with the UL approved fuse installed. Figure 2-2 illustrates how to open the fuse drawer.
4. Connect the proper power cord from the rear-panel power connector (Figure 2-1) to the power system.

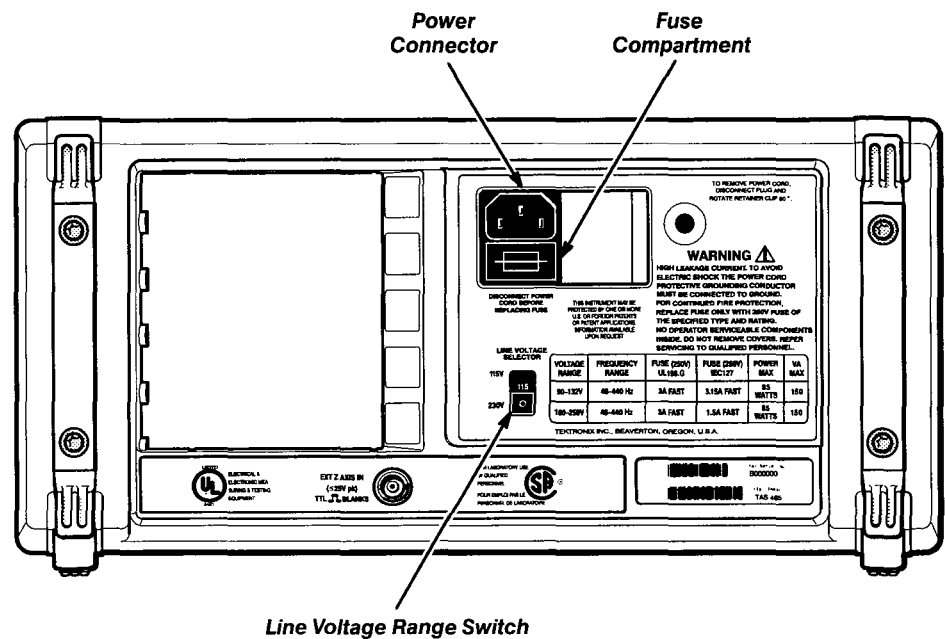

Figure 2-1: Rear Panel

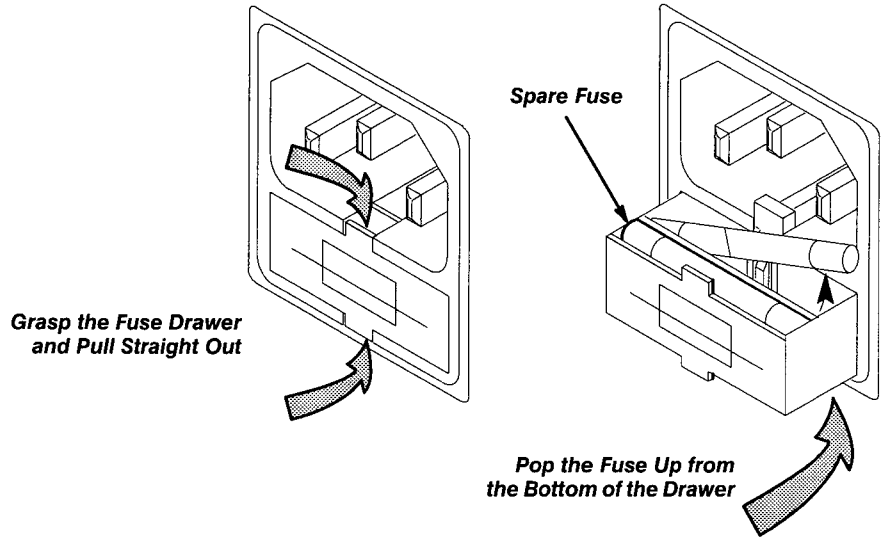

Figure 2-2: Fuse Compartment

5. Be sure you have the appropriate operating environment. Specifications for temperature, relative humidity, altitude, vibrations, and emissions are in Section 1, *Specifications*.
6. Leave space for cooling. Do this by verifying that the air intake and exhaust holes on the sides of the cabinet are free of any airflow obstructions. Leave at least 5.1 cm (2 in.) free on each side.
7. Press the **POWER** button to power on the oscilloscope.

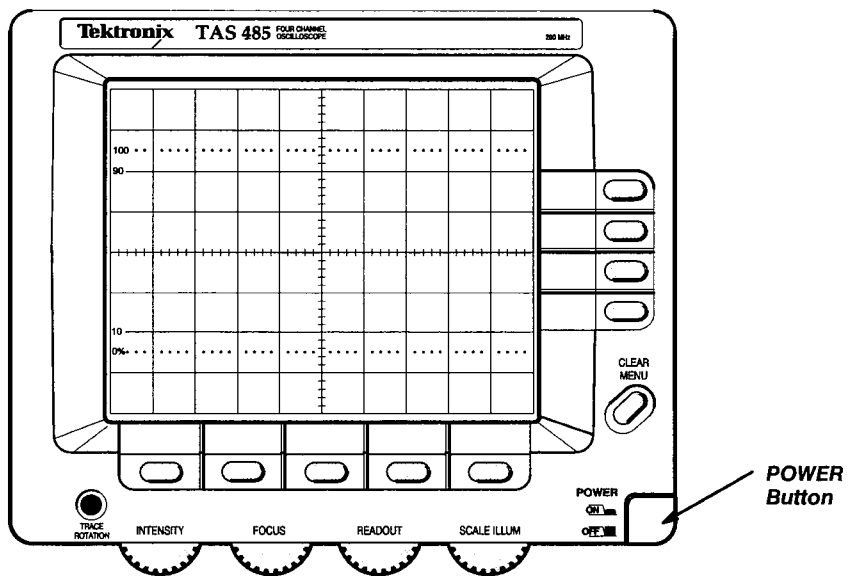

Figure 2-3: POWER Button

Quick Start

This section helps you get acquainted with basic controls and operating systems of the TAS 475 and TAS 485 Analog Oscilloscopes once you have power applied. Review *At a Glance* in Section 2 if you want an overview of all controls and connectors.

Selecting and Deselecting Input Channels

The TAS 475 and TAS 485 Oscilloscopes have four input channels. You can display the channels separately or simultaneously. The following steps demonstrate how to select and deselect channels for display.

1. Power on the oscilloscope and wait for the self tests to complete.
2. Press the **CH 1** button located on the front panel. The **CH 1** indicator lights, channel 1 is displayed, and vertical controls and menus are assigned to channel 1.
3. Press the **CH 2** button located on the front panel. The **CH 2** indicator lights, channel 2 is displayed, and controls and menus are assigned to channel 2.
4. Press the **CH 1** button, assigning control to channel 1.
5. Press the **WAVEFORM OFF** button, removing channel 1 from the display and leaving channel 2 displayed.

Using the Menus

The TAS 475 and TAS 485 Oscilloscopes use menus for many instrument settings. In the following steps, you will set only channel 1 on and turn the cursors on.

1. Press the **WAVEFORM OFF** button until only channel 1 is displayed.
2. Press the **CURSOR** menu button.
3. Set the delta volts (Δ VOLT) cursors on (using the following guide).

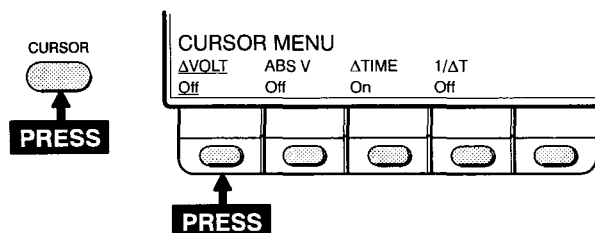

Quick Start

- Now two horizontal bar cursors are displayed. The active (movable) one is a solid line and the inactive one is a dashed line. Use the General Purpose Knob to move the active cursor and use the **TOGGLE** button to select which cursor is active.

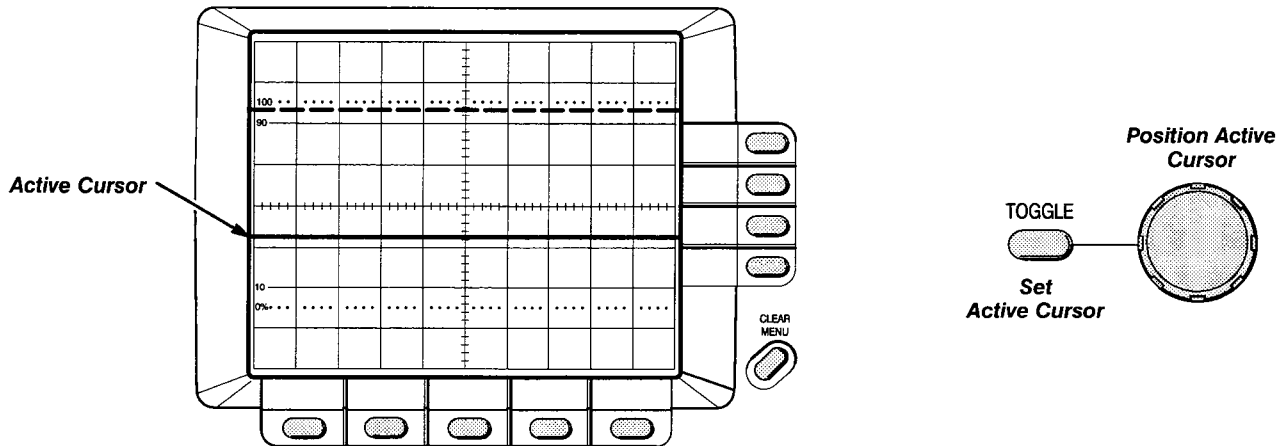

Connecting a Signal

The TAS 475 and TAS 485 Oscilloscopes accept signals through the front panel input connectors labeled **CH 1**, **CH 2**, **CH 3**, and **CH 4**. The probes you use for taking measurements should only be those supplied with the TAS 475 and TAS 485 Oscilloscopes. Connecting signals to the TAS 475 and TAS 485 Oscilloscopes is also possible with the use of 50 Ω coaxial cables.

Before using any probe to take measurements, compensate the probe to match the input channel. See *Compensating the Probe* on page 2-5.

Using AUTOSET

The **AUTOSET** feature of the TAS 475 and TAS 485 Oscilloscopes automatically sets most of the front panel controls.

- Connect the probe compensation signal (from the **PROBE COMP** connector on the front panel) to either channel of the oscilloscope and display that channel (see Figure 2-5). Turn all other channels off.
- Press the **AUTOSET** button on the front panel. Wait one to three seconds to allow the instrument to adjust all the control settings.

The instrument will trigger on the waveform, display at least one complete cycle, and center it horizontally on the CRT. The baseline of the waveform will be at the center horizontal graticule line. The intensity level is increased if set too low for a viewable display.

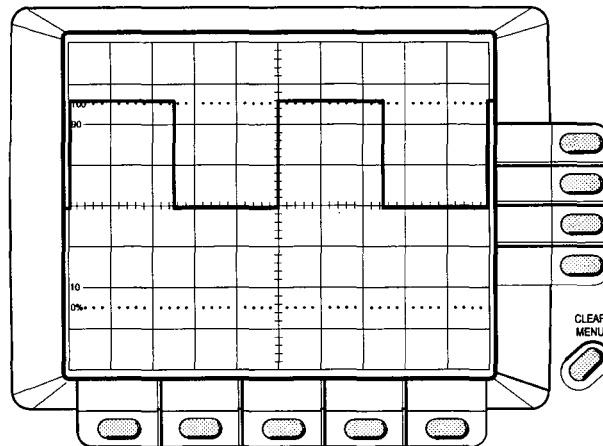

Figure 2-4: Probe Compensation Signal Displayed after AUTASET

Compensating the Probe

Passive probes require compensation to ensure maximum distortion-free input to the TAS 475 and TAS 485 Oscilloscopes. Before taking any measurements using a probe, first check the compensation of the probe and adjust it to match the channel inputs. The signal source for this check is the front-panel **PROBE COMP** signal (Figure 2-5).

1. Attach the probe to one of the channel input connectors along the lower right of the front panel.
2. Attach the probe tip to the **PROBE COMP** connector.

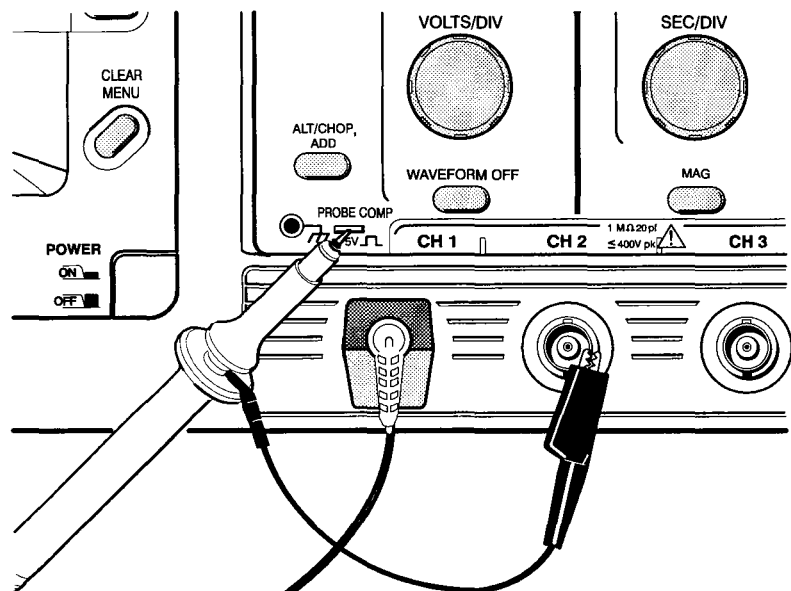
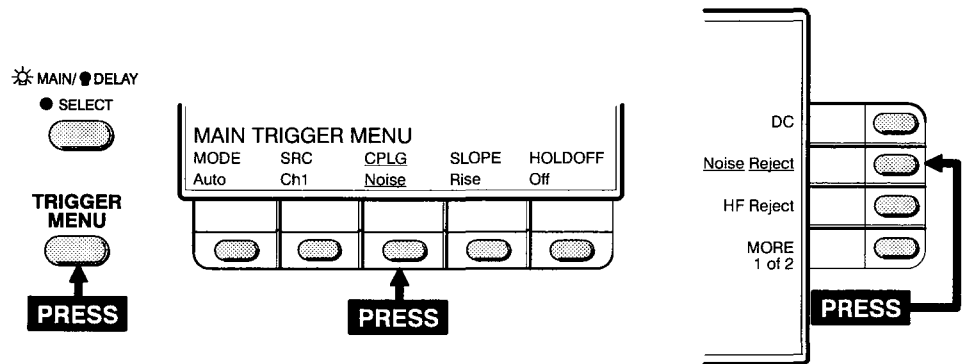
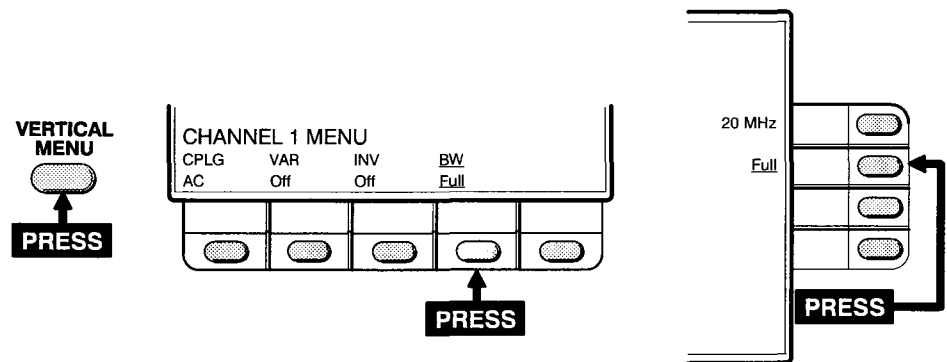

Figure 2-5: Connections for Compensating a Probe

3. Select the appropriate input channel by pressing either the **CH 1**, **CH 2**, **CH 3**, or **CH 4** front-panel button.
4. With the probe attached between an input channel and the probe compensation output of the oscilloscope, press the **AUTOSET** button on the front panel.
5. Set the vertical scale to 1 V using the **VOLTS/DIV** control.
6. Center the waveform vertically using the vertical **POSITION** control.
7. Set the horizontal scale to 200 μ s using the **SEC/DIV** control.
8. Set the trigger coupling to **Noise Reject** (use the following guide).



9. Set the vertical bandwidth to **Full** (use the following guide).



10. Check that the displayed waveform is a square wave with flat tops and bottoms. See Figure 2-6 for illustrations indicating proper and improper probe compensation.

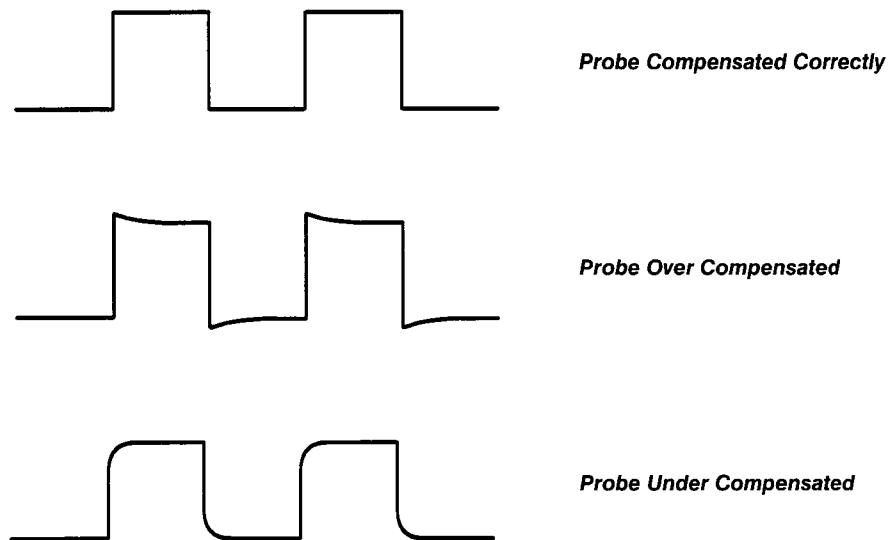

Figure 2-6: How Probe Compensation Affects Signals

11. Adjust the low frequency compensation adjustment, located in the probe body, for the best possible square wave. See Figure 2-7 for the location of the low frequency adjustment.

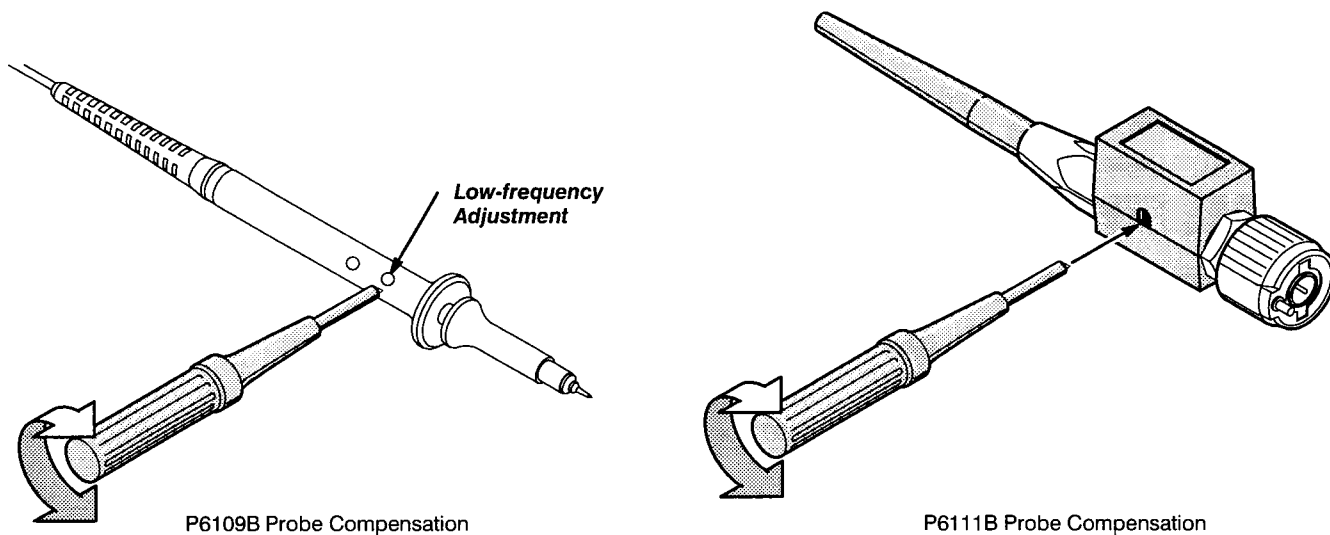

Figure 2-7: Location of Probe Head Adjustment

Menu Map

Figure 2-8 is a map of the menus to help you locate menu driven functions and their available settings. Refer to the *Instruction* manual for operating information about each menu.

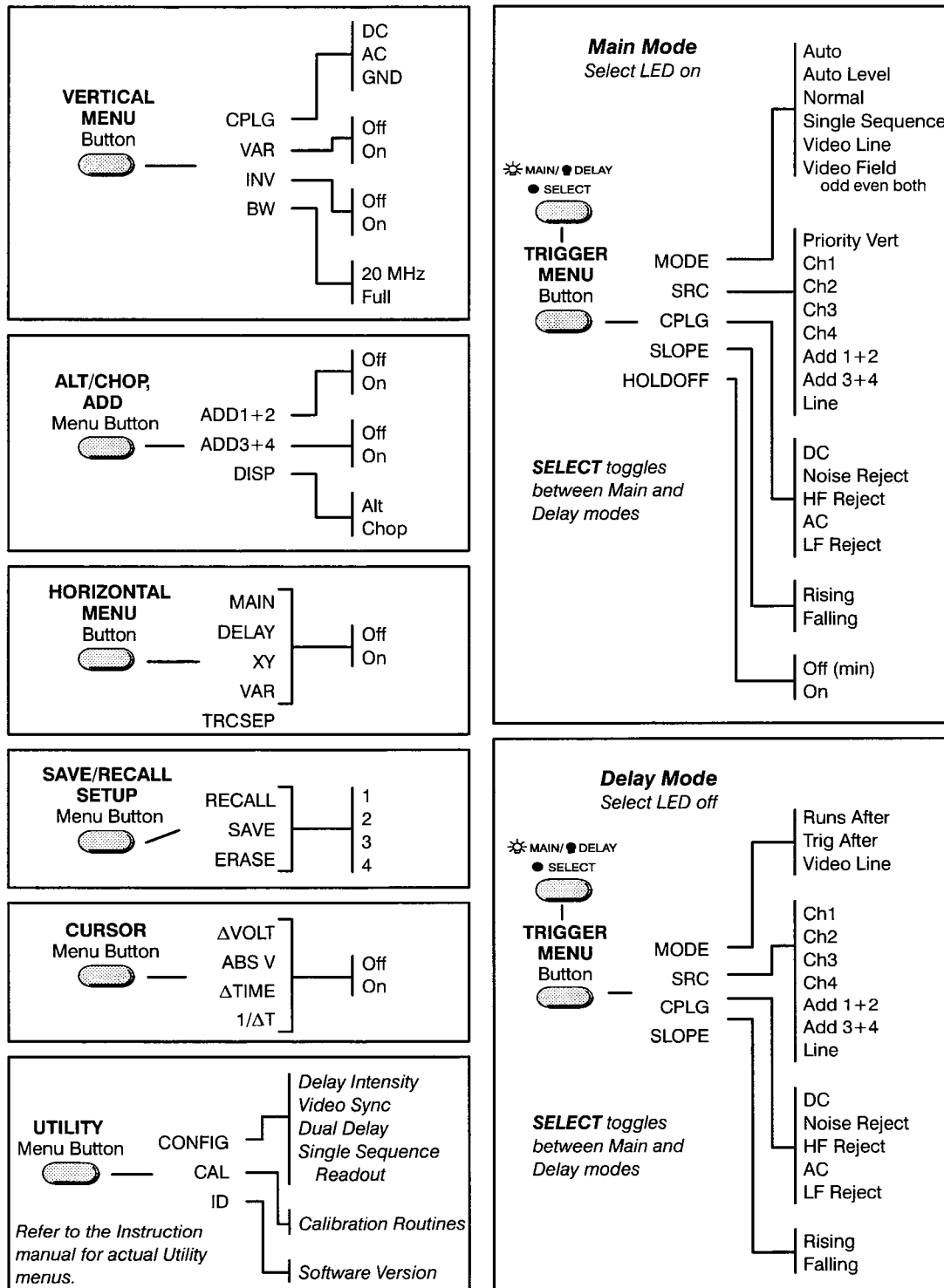

Figure 2-8: Menu Map

Circuit Description

This section describes the electrical operation of the Tektronix TAS 475 and TAS 485 Analog Oscilloscopes. Refer to the schematics in the *Diagrams* section as necessary.

Logic Conventions

This manual refers to digital logic circuits with standard logic symbols and terms. Unless otherwise stated, all logic functions are described using the positive logic convention: the more positive of the two logic levels is the high (1) state and the more negative level is the low (0) state. Signal states may also be described as “true” meaning their active state or “false” meaning their non-active state. The specific voltages that constitute a high or low state vary among the electronic devices.

Active-low signals are indicated by a tilde (~) prefixed to the signal name (~RESET). Signal names are considered to be either active-high, active-low, or to have both active-high and active-low states.

Module Interconnection

Figure 3-1 shows the interconnection paths between the modules of the TAS 475 and TAS 485 Oscilloscopes.

Circuit Description

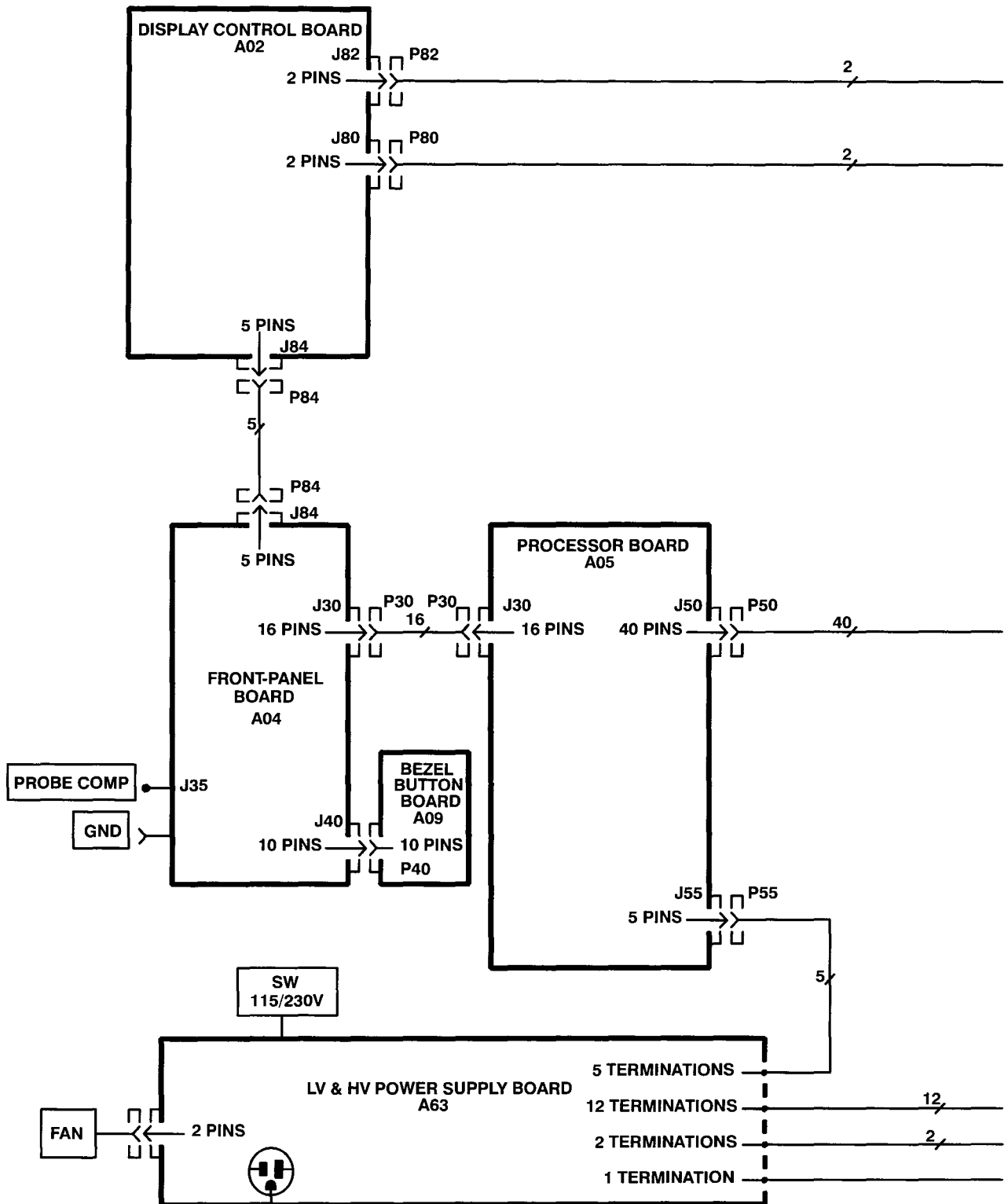

Figure 3-1: Block Diagram

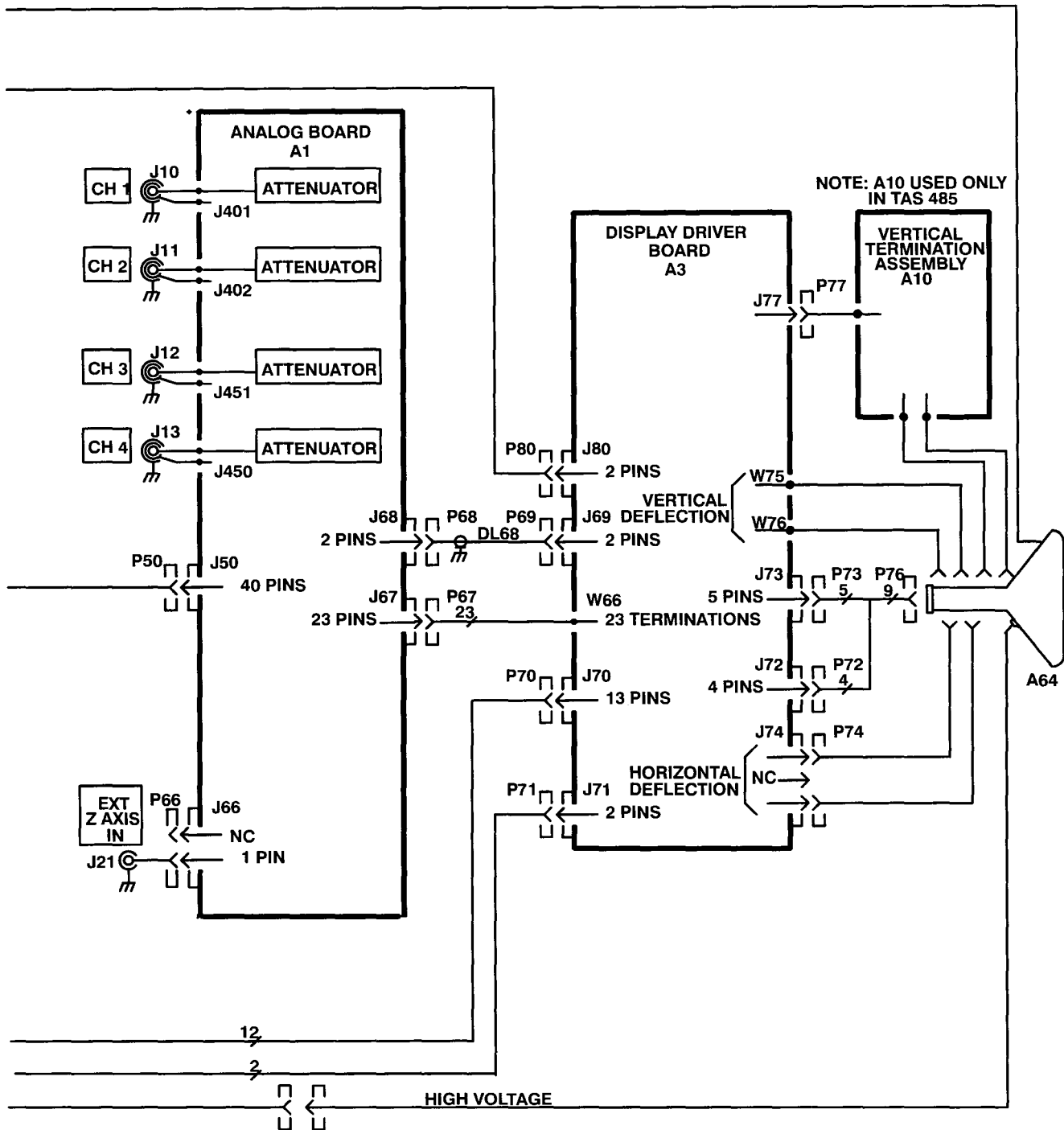

Figure 3-1: Block Diagram (Cont.)

Analog Board

A signal enters the oscilloscope through a probe connected to a BNC on the A1 Analog board.

Attenuators A1

The attenuator hybrids AT401, AT402, AT450, and AT451, and the vertical preamplifier IC, select the input coupling, attenuation factor, variable gain, and the invert function. The processor system controls and calibrates the attenuators.

Probe Coding Interface A1

Probe coding interface signals pass through the A1 Analog board to the A5 CPU board and then to the A4 Front Panel board. The probe interface signals are digitized on the Front Panel board and communicated to the processor system to control the instrument.

Analog Acquisition Hybrid A1

The input signals are routed to the highly integrated analog acquisition hybrid, U405, which does the analog processing required to provide vertical, horizontal, and Z-axis signals to the A3 Display Driver board. Under control of the processor, the hybrid provides vertical signal processing, triggers, sweeps, sequencing logic, and intensity control.

Processor System

The processor board is a microcontroller design. Microcontroller U201 is the core of the circuit, operating at 16 MHz. The primary function of the processor is to receive input from the front panel, display the readout, and control the A1 Analog board.

The processor board can be divided into five subsystems: the processor, the ROM/RAM, the readout, the front-panel interface, and the analog board interface. A description of each subsystem follows.

Processor Subsystem A5

The processor subsystem consists of a 32-bit integrated microcontroller and its supporting circuits. It contains four peripheral modules; the CPU, a general-purpose timer (GPT), a queued serial module (QSM), and a system integration module (SIM).

The CPU is based on the MC68020 instruction set and can utilize the extensive software base for the Motorola M68000 Family.

The GPT inputs are used for measuring the main and delay sweep gates, as well as the measurement latches. The outputs of the GPT are used for loading or resetting various sections of the analog board.

The QSM is primarily used as a synchronous bus for setting up the internal register bits of the GCS, HS, preamp and DACs on the analog board.

The SIM module does all of the chip selecting for all of the addressable ICs on the processor board. U201 has three types of support circuitry. The first type is pull-up resistors for IRQ lines and for configuring the processor boot up. The second type is a crystal oscillator. The crystal oscillates at 32 kHz. The processor uses a phase lock loop to create a 16 MHz system clock from this crystal. The third type is a power-on reset circuit. The reset circuit, consisting mainly of U207, is a passive circuit that monitors VCC. When the power supply exceeds 4.5V, U207 releases the reset line allowing the processor to run. If VCC drops below 4.5V a reset occurs.

ROM/RAM Subsystem A5

The ROM/RAM subsystem consists of 256 kb of Flash ROM, 256 kb of static RAM, and 64 kb of non-volatile static RAM. The Flash ROM has a requirement which states that it must not have an OE during a write cycle. Consequently, the gates of U221 in this subsystem prevent this from happening.

Readout Subsystem A5

The readout subsystem consists of a custom readout IC, two DACs, a 2.5 V reference voltage, and some support resistors and capacitors for compensation and filtering. The readout IC has an internal RAM into which the processor puts ascii characters. The processor also controls the state of the readout IC for calibration, cursor positioning, and update rate. The readout IC itself then drives the vertical and horizontal DACs as well as the blanking.

Front-Panel Interface Subsystem A5

The front-panel interface subsystem consists of U215 (DUART), and its 3.686 MHz crystal. The processor communicates to the front-panel processor through an RS232 like interface. This interface is maintained by the DUART, running at 9600 baud. The DUART is connected to IRQ5 on the processor. U201 talks to U215 using data lines D8 through D15.

Analog Board Interface Subsystem A5

The analog board interface subsystem consists of an ECL to CMOS converter and a CMOS to ECL converter. The SGMAIN lines coming from the analog board are ECL. These lines were converted to CMOS by using two transistors and a couple of resistors.

Display Assembly

All information (waveforms, text, and cursors) is displayed by the A3 Display Driver board. It generates the high voltages necessary to drive the CRT. It also contains the vertical and horizontal amplifier circuitry.

Vertical Output A3

The vertical output amplifier provides the final stage of amplification of the vertical signal. The output of the vertical amplifier is connected to the CRT vertical plates. Vertical time and frequency compensation networks, some which are adjustable are also contained in this circuit block. The compensation networks corrects for errors in the time response of the vertical delay-line and variations in time and frequency response of the total vertical system. The vertical signal at the input of the vertical output stage is sampled and feedback to the trigger circuitry on the analog board. This feedback vertical signal is used for purposes of calibration.

Horizontal Output A3

The horizontal output amplifier provides the final stage of amplification of the horizontal signal and drives the CRT horizontal plates directly. The input signal from the analog board is current in and the output signal to the CRT is a voltage.

High Voltage A3

This circuitry provides the necessary static and dynamic levels to support the CRT biasing and Z-axis drive. The Z-axis amplifier provides amplification of the Z-axis signal from the analog board which is a current. The output of the Z-axis amplifier is then applied to the DC restorer circuitry which level shifts this signal to the cathode level. A focus amplifier receives its input signal from a user control on the front panel. This enables the user the ability to optimize the CRT focus. Additional circuitry is provided to support the necessary bias and operation levels for the CRT.

The External Z-Axis connector provides the ability to modulate the Z-axis amplifier circuit on the A3 Display Driver board, thus modulating or blanking the intensity of the CRT display.

Vertical Termination (TAS 485 only) — The A10 Vertical Termination hybrid provides the correct impedance for the vertical deflection plates in the CRT.

Front Panel

The processor system sends and receives information to and from the A4 Front Panel board. The Front Panel board reads the front-panel controls and changes in their settings are reported to the processor system. The front-panel processor turns the LEDs on and off, generates the probe compensation signal, and processes the probe coding interface signals.

Menu Switches A4

Front-panel menu switches are read by the Front Panel board and changes in menu selections are sent to the processor system.

CPU A4 

U101 is the front-panel processor (FPP) and monitors the front-panel controls. It is a single chip microprocessor with built-in RAM, ROM, A-to-D converter, programmable timer, and serial communications interface.

The front-panel processor reports any changes in state of the front-panel controls to the U201 on the A5 CPU board via the serial communication interface.

The programmable timer TCMP1 (U101 pin 2) produces a 0 to 5V, 1kHz square wave signal (CALSIG) that is used for probe compensation. TCMP2 (U101 pin 1) produces a 0 to 5V, 1 kHz signal that is converted to ECL level (DITHER) by the resistive divider R503–R505. DITHER is used by the Analog Signal Processor on the analog board.

FPP Pots & Probes A4  

The pot/probe scanner working with the A-to-D converter internal to the front-panel processor digitizes the inputs and reports the amount a pot has turned and the type of probe used.

Control lines to the analog multiplexers U420 and U421 determine whether to scan for pots or probes. If pots are to be scanned, one of 10 possible pot inputs are read from either multiplexer U420 or U421. The voltage at the wiper of the pot selected is applied to the front-panel processor and digitized. The amount and direction of change from the previous stored value is calculated and sent to the host processor 68331 on the processor board.

The intensity and readout intensity pots on the front bezel are stopped pots and represent one input each on the analog multiplexer U420. The other 8 pot inputs on U420 and U421 represent the 4 continuous rotation pots on the front panel which are made of two wipers separated by 180 degrees and contact a single resistive arc. Each continuous rotation pot represents two inputs to the multiplexers.

The analog multiplexer U420 also doubles for selecting one of the 4 possible probe inputs. The probe code resistance from the P6139 probe is converted to a voltage by the pull-up resistors R411–R414. This voltage is read by the pot/probe scanner and the probe type is determined and sent to the host processor.

LEDs & Driver A4 

There are 5 LEDs (light emitting diodes) on the front panel which are connected between the outputs of an 8 bit LED latch U202 and a pull-up resistor to +5 V. When a particular LED needs to be turned on or off, the front-panel processor converts the LED identification received from the host processor to the correct LED address on the latch (U202) and changes the state of the LED.

Circuit Description

Switches A4 

The front-panel switches and menu switches are arranged in an array of 9 rows and 8 columns. The switch scanner sets the nine row lines low in sequence and performs an eight column scan to check for any changes in state and reports these changes to the host processor. When a switch is closed, one row is connected to one column line through an isolation diode and the column line is pulled low indicating a switch closure.

Low Voltage Power Supply

The low voltage power supply is a switching power converter. It supplies power to all oscilloscope circuitry.

The **POWER** switch, located on the front panel, controls all power to the oscilloscope including the power supply.

Fan

The fan provides forced air cooling for the oscilloscope. It connects to +12 V on the A63 Power Supply board.

General Instructions

This Performance Verification section is divided into two subsections, *Brief Performance Checks* and *Performance Tests*.

The *Brief Performance Checks* section contains procedures to verify the operation of the TAS 475 and TAS 485 Analog Oscilloscopes.

The *Performance Tests* section contains procedures to confirm the performance of the TAS 475 and TAS 485 Oscilloscopes to its warranted specifications.

Using the Brief Performance Checks Procedures

The *Brief Performance Checks* contain three procedures: Power-On Self Tests, Functional Tests, and Temperature Compensation Calibrations. Completing these checks takes approximately one hour.

The *Self Tests* are performed each time the oscilloscope is powered on.

The *Functional Tests* use the probe compensation output on the front panel as a test-signal source for further verifying that the oscilloscope functions properly. A standard-accessory probe, included with this oscilloscope, is the only equipment required.

To rapidly confirm that this oscilloscope functions and was adjusted properly, perform the procedures in the *Functional Tests* section; which begin on page 4-3.

Advantages: These procedures are quick to do, require no external equipment or signal sources, and provide high confidence that the oscilloscope will perform properly. These also provide hands-on experience to become familiar with the controls and menus.

The *Temperature Compensation Calibrations* allow you to adjust the display accuracy of the oscilloscope.

Using the Performance Tests Procedures

The *Performance Tests* confirm that the TAS 475 and TAS 485 Oscilloscopes perform as specified. The *Performance Tests* begin on page 4-13. Completing these tests takes approximately two hours and requires suitable test equipment. (See *Equipment Required* on page 4-13.)

Advantages: These procedures add direct checking of warranted specifications.

Conventions

The procedures in this section provide the following information:

- Title of test
- Equipment required (if applicable)
- Procedure

Where instructed to use a front-panel control or select from a menu, the name appears in boldface type. For example, “press **VERTICAL MENU**;

then “set **CPLG** to **DC**.”



The symbol at the left is accompanied by information you must read to do the procedure properly.

These procedures make references to the graticule lines. For example, “position the cursor to the second vertical graticule line.” Figure 4-1 shows how to interpret the references.

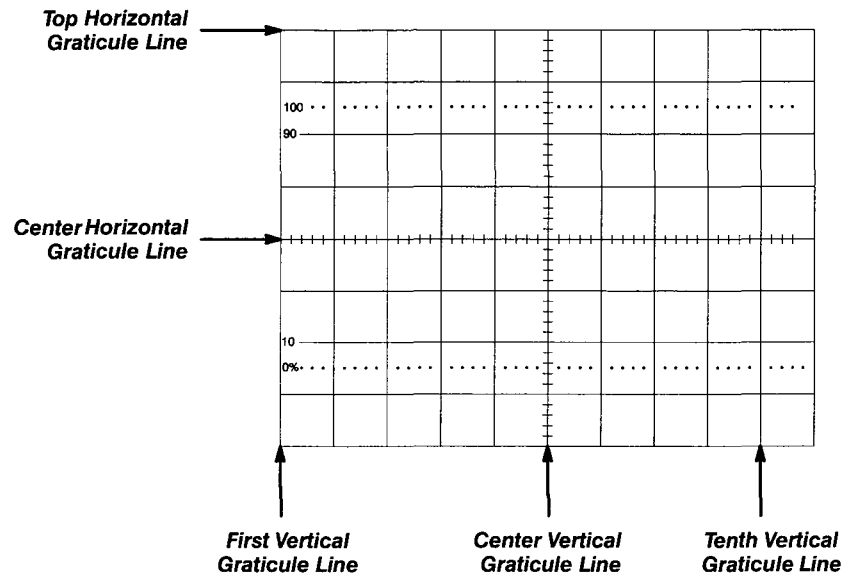

Figure 4-1: Graticule References

These procedures may ask you to check for a stable display. A stable display is consistent. The display should not have its trigger point switching slopes (double trigger) nor should it “free-run.” The **MAIN SWP TRIG'D LED** should remain lit.

Brief Performance Checks

This section contains three brief procedures: two that verify the operation of the TAS 475 and TAS 485 Analog Oscilloscopes and one to perform a brief calibration to compensate for temperature variances.

The *Power-On Self Tests* use internal routines (performed at each power on) to confirm basic functionality and proper adjustment.

The *Functional Tests* further verify that the oscilloscope functions properly. These tests utilize the front panel **PROBE COMP** signal and a standard accessory probe.

The *Temperature Compensation Calibrations* use internal routines and actions from you to adjust the display accuracy of the oscilloscope. These adjustments are typically necessary only when the operating temperature and the last calibration temperature varies more than 5° C. However, performing these compensations before making a critical measurement ensures optimum accuracy.

If any of these tests return a failed message or do not perform as stated, contact your local Tektronix service center or sales engineer for more information.

Power-On Self Tests

These tests verify that the internal power-on diagnostics passed by confirming no error messages are reported on-screen.

Functional Tests

The purpose of these procedures is to confirm that this oscilloscope functions properly. The only equipment required is a standard accessory probe.



These procedures verify function; that is, they verify that oscilloscope *operates*. They do *not* verify that it operates within limits.

Therefore, when the instructions in the functional tests that follow call for you to verify that a signal appears on screen “that is about five divisions in amplitude” or “has a period of about six horizontal divisions”, do *not* interpret the quantities given as limits. Operation within limits is checked in *Performance Tests*, which begin on page 4-13.



DO NOT make changes to the front-panel settings that are not called out in the procedures. Each verification procedure requires you to set the oscilloscope to certain default settings before verifying functions. If you make changes to these default settings, other than those called out in the procedure, you may obtain invalid results. In this case, begin the procedure again from step 1.

Functional Tests Prerequisites

1. Power on the oscilloscope and allow a 20 minute warm-up before performing this procedure; adjust the **READOUT** control to display the readout and the **INTENSITY** control to display waveforms.
2. Disable the dual delay with the following menu selections.
 - a. Press the **UTILITY** button and select **CONFIG** from the main menu.
 - b. Select **MORE** until you can select **Dual Delay Disabled**.
3. Press the **ALT/CHOP, ADD** button and set **ADD1+2** and **ADD3+4** to **Off**.
4. Install the probe on **CH 1**. Connect the probe tip to **PROBE COMP** on the front-panel; connect the probe ground to the ground barrel of an unused input BNC (see Figure 4-2).

Some functional checks require that you install the probe on connectors other than **CH 1**. All functional checks use the **PROBE COMP** on the front-panel as the signal source.

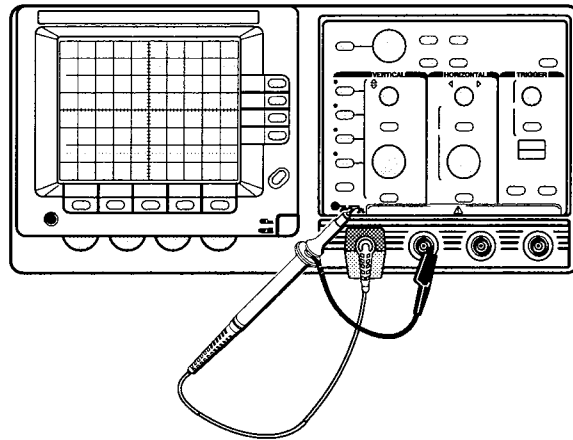

Figure 4-2: Test Hookup for Functional Tests

Verify the Probe Compensator Output

1. Press the **WAVEFORM OFF** button until the readout indicates that only channel 1 is selected.
2. Press the **AUTOSET** button.
3. Press the **VERTICAL MENU** button and set **CPLG** to **DC**.
4. Set the volts/div scale to 1 V and vertically center the display.
5. Set the sec/div scale to 500 μ s.
6. Press the **CURSOR** button and set Δ VOLT to **On**.

7. Align the active cursor to the top of the signal using the General Purpose Knob.
8. Press the **TOGGLE** button and align the active cursor to the bottom of the signal using the General Purpose Knob.
9. Verify that the Δ Volts readout is about 5.2 V.
10. Set $1/\Delta T$ to **On**.
11. Align the active cursor to a rising edge of the signal using the General Purpose Knob.
12. Press the **TOGGLE** button and align the active cursor to the next rising edge of the signal using the General Purpose Knob.
13. Verify that the $1/\Delta T$ readout is about 1 kHz.
14. Set Δ TIME to **On**.
15. Verify that the Δ Time readout is about 1 ms.

Verify the Input Channels

1. Display the channel to be verified and turn all others off.
2. Install the probe on the channel to be verified.
3. Press the **AUTOSET** button.
4. Press the **VERTICAL MENU** button and set **CPLG** to **DC**.
5. Verify that the channel is operational, confirming the following statements are true.
 - The vertical scale readout is set to 2 V for the channel under test and a square wave signal about 2.6 divisions in amplitude is on-screen.
 - Pressing the **SET LEVEL TO 50%** button sets the trigger level readout to approximately 2.7 V.
 - The vertical **POSITION** control moves the signal up and down the screen when rotated. Return the bottom portion of the displayed waveform to the center horizontal graticule line.
 - Turning the **VOLTS/DIV** control counterclockwise and clockwise decreases and increases the amplitude of the waveform. Return the volts/div scale to 2 V.

Brief Performance Checks

6. Press the **VERTICAL MENU** button and select **CPLG**. Select the following coupling types and verify the display.
 - Select **DC** coupling and verify that the waveform amplitude is positive-going from the center horizontal graticule line.
 - Select **AC** coupling, press the **SET LEVEL TO 50%** button, and verify that the waveform is centered at about the center horizontal graticule line.
 - Select **GND** coupling and verify that a straight line is displayed (no waveform).
7. Return the coupling to **DC** and press the **CLEAR MENU** button.
8. Repeat this procedure until all input channels are verified.

Verify the Alt/Chop and Add Functions

1. Install the probe on **CH 1**.
2. Press the **WAVEFORM OFF** button until the readout indicates channel 1 is the only selected channel.
3. Press the **AUTOSET** button.
4. Press the **CH 2** button, then position the channel 2 trace to the bottom horizontal graticule line.
5. Press the **WAVEFORM OFF** button, removing the channel 2 display.
6. Press the **ALT/CHOP, ADD** button and set **ADD1+2** to **On**.
7. Verify that a second waveform of approximately 2.6 divisions amplitude has been added to the display.
8. Set **ADD1+2** to **Off**.
9. Install the probe on **CH 3**.
10. Press the **CH 3** button.
11. Press the **CH 1** button, then the **WAVEFORM OFF** button, removing the channel 1 display.
12. Press the **CH 2** button, then the **WAVEFORM OFF** button, removing the channel 2 display.
13. Press the **AUTOSET** button.
14. Press the **CH 4** button, then position the channel 4 display to the bottom horizontal graticule line.
15. Press the **WAVEFORM OFF** button, removing the channel 4 display.
16. Press the **ALT/CHOP, ADD** button and set **ADD3+4** to **On**.
17. Verify that a second waveform of approximately 2.6 divisions amplitude has been added to the display.
18. Set **DISP** to **Chop**.

19. Set the sec/div scale to 100 ms.
20. Verify that the two waveforms are displayed simultaneously.
21. Set **DISP** to **Alt**.
22. Verify that the two waveforms are displayed alternately.
23. Set **ADD3+4** to **Off**.
24. Press the **CLEAR MENU** button.

Verify the Time Base

1. Press the **WAVEFORM OFF** button until the readout indicates channel 1 is the only selected channel.
2. Install the probe on **CH 1**.
3. Press the **AUTOSET** button.
4. Verify that the main time base is operational, confirming the following statements are true.
 - One period of the square wave is about five horizontal divisions.
 - Rotate the **SEC/DIV** control clockwise and verify that the waveform expands (more horizontal divisions per period of waveform) and that counterclockwise rotation contracts it.
 - Set the sec/div scale to 1 ms and verify that approximately one period of waveform per horizontal division is displayed.
 - Rotate the horizontal **POSITION** control and verify that the waveform moves left and right on-screen.
 - Pressing the **MAG** button changes the sec/div scale from 1 ms to 100 μ s and one period of the square wave is about ten horizontal divisions. Return to a non-magnified display by pressing the **MAG** button again.
5. Press the **HORIZONTAL MENU** button and set **DELAY** to **On**.
6. Set the delayed sec/div scale to 500 μ s.
7. Press the **TRIGGER MENU** button and set **MODE** to **Runs After**.
8. Press the **HORIZONTAL MENU** button.
9. Select **TRCSEP** from the main menu and vertically position the delayed time base below the main time base using the General Purpose Knob.
10. Select **DELAY** from the main menu.

Brief Performance Checks

11. Verify that the delayed time base is operational, confirming the following statements are true.
 - The main sweep has an intensified zone of approximately 5.5 horizontal divisions. Adjust the **INTENSITY** level if necessary to view the entire intensified zone.
 - Rotating the General Purpose Knob clockwise moves the intensified zone to the right on-screen. Position the intensified portion to the center of the screen.
12. Adjust the delayed sec/div scale to 200 μ s.
13. Set **MAIN** to **Off** and confirm that only the delayed sec/div scale is displayed and the period of the square-wave signal is about five horizontal divisions.
14. Set **MAIN** to **On** and **DELAY** to **Off**.

Verify the Trigger System

1. Press the **WAVEFORM OFF** button until the readout indicates channel 1 is the only selected channel.
2. Press the **AUTOSET** button.
3. Set the sec/div scale to 1 ms.
4. Press the **TRIGGER MENU** button and set **MODE** to **Auto**.
5. Verify that the main trigger is operational, confirming that the following statements are true.
 - Rotating the trigger **LEVEL** control changes the main trigger level readout.
 - Rotating the trigger **LEVEL** control through its range triggers and untriggers the display. Leave the signal untriggered.
 - Pressing the **SET LEVEL TO 50%** button triggers the signal and the trigger level readout indicates approximately 2.7 V.
6. Press the **HORIZONTAL MENU** button and set **DELAY** to **On**.
7. Set the delayed sec/div scale to 500 μ s.
8. Verify that the delayed sweep is operational, confirming that an intensified zone appears on the main sweep.
9. Press the **TRIGGER MENU** button and set **MODE** to **Trig After** and **SRC** to **Ch1**.

10. Verify that the delayed trigger is operational, confirming that the following statements are true.
 - Rotating the trigger **LEVEL** control changes the delayed trigger level readout.
 - Rotating the trigger **LEVEL** control through its range triggers and untriggers (intensified zone displayed and not displayed) the delayed sweep. Leave the signal untriggered.
 - Pressing the **SET LEVEL TO 50%** button triggers the signal, the trigger level readout indicates approximately 2.7 V, and the intensified zone is displayed.
11. Press the **HORIZONTAL MENU** button and set **DELAY** to **Off**.
12. Set the sec/div scale to 50 ms.
13. Press the **TRIGGER MENU** button and set **MODE** to **Single Sequence** and confirm the following statements are true.
 - There is no waveform displayed.
 - Pressing the **RESET S SEQ** button causes one sweep of the waveform display to occur.
14. Set the sec/div scale to 1 ms.
15. Set **MODE** to **Auto Level**.
16. Disconnect the probe from the oscilloscope.

Temperature Compensation Calibrations

The procedures that follow allow you to quickly compensate the calibration of the oscilloscope for any external temperature variations. This ensures the most accurate measurements. No test equipment is required to perform these procedures.



Optimum instrument performance depends on the recommended 20 minute minimum warm-up time prior to performing the following calibration routines. All calibration routines require a successful completion (no "failed" message).



The Temperature Compensation Calibrations affect the accuracy of the display system; therefore, they should only be performed by a qualified technician.

Horizontal Sweep Path

1. Press the **AUTOSET** button.
2. Press the **UTILITY** button and select **CAL** from the main menu.
3. Select **Horizontal Sweep Path** from the sub menu, initiating the routine.

Brief Performance Checks

The **Horizontal Sweep Path** routine takes about 20 seconds to complete its initial calibrations. Once complete, two dots are displayed. The displayed dots are used for the next horizontal calibration steps.

NOTE

*The following steps use both the General Purpose Knob and the **TOGGLE** button to make adjustments. The General Purpose Knob performs two functions: to adjust gain and centering. Pressing the **TOGGLE** button selects the function of the General Purpose Knob.*

4. Use a combination of the **TOGGLE** button and the General Purpose Knob to position the two dots eight divisions apart, centered horizontally (see Figure 4-3).

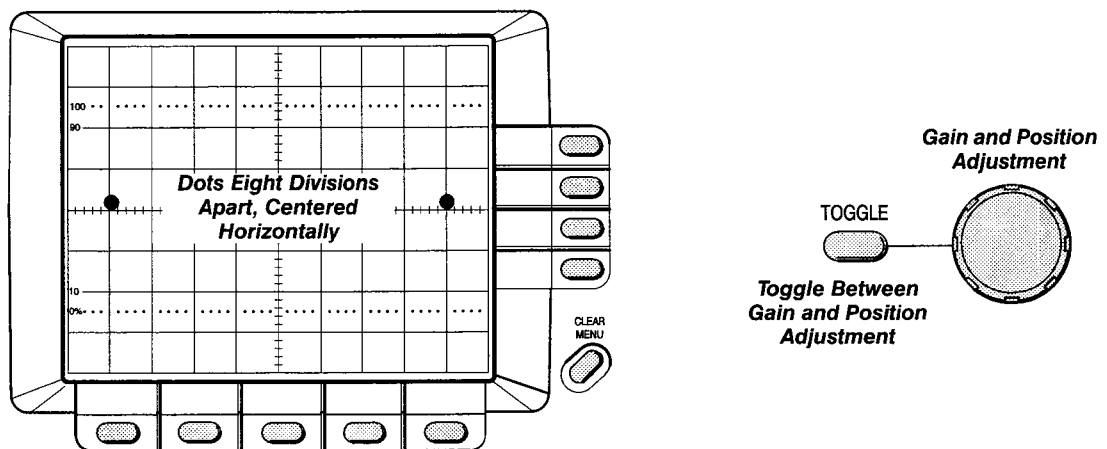

Figure 4-3: Horizontal Adjustments (One)

5. Select **Done** when you have the appropriate display.
6. Again, use a combination of the **TOGGLE** button and the General Purpose Knob to position the two dots eight divisions apart, centered horizontally (see Figure 4-3).
7. Select **Done** when you have the appropriate display.
8. One dot is now displayed.
9. Use a combination of the **TOGGLE** button and the General Purpose Knob to horizontally center the single dot at the center of the screen (see Figure 4-4).

Continue to press the **TOGGLE** button and adjusting the dot to center screen with the General Purpose Knob until the dot stays horizontally centered while pressing the **TOGGLE** button.

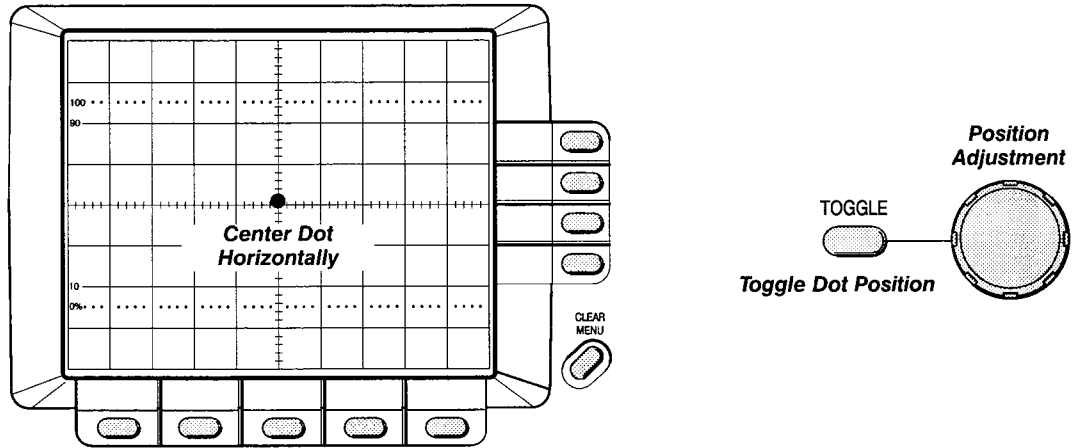

Figure 4-4: Horizontal Adjustments (Two)

10. Select **Done** when you have the appropriate display.
11. Two vertical lines are now displayed.

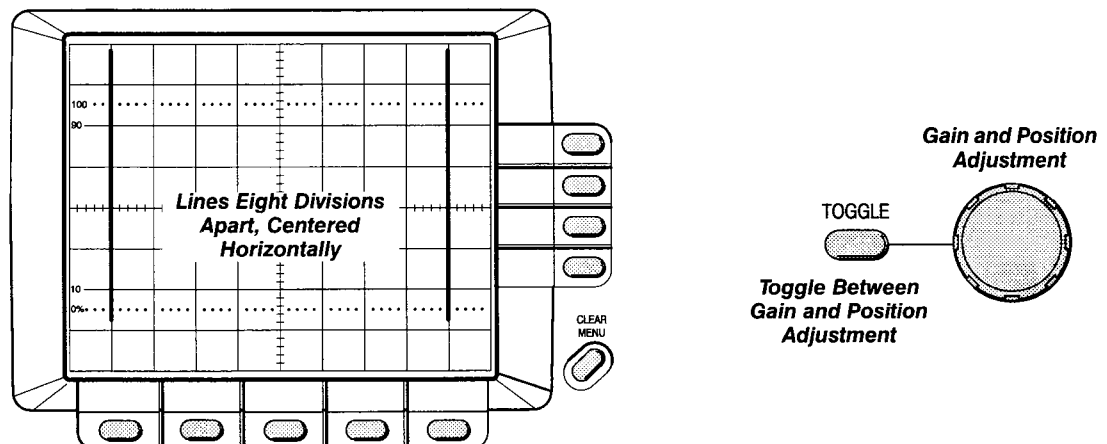

Figure 4-5: Horizontal Adjustments (Three)

12. Use a combination of the **TOGGLE** button and the General Purpose Knob to position the two lines eight divisions apart, centered horizontally (see Figure 4-5).
13. Select **Done** when you have the appropriate display.
14. A **pass** or **failed** status appears on the screen.
15. Select **Done** to exit the routine, displaying a **Calibration Finished** message.

Vertical Signal Path

1. Press the **AUTOSET** button.
2. Press the **UTILITY** button and select **CAL** from the main menu.
3. Select **Vertical Signal Path** from the sub menu, initiating the routine.
4. Remove any input signals from the oscilloscope.
5. Select **Done**.

The **Vertical Signal Path** routine takes less than two minutes to complete. When finished, a *pass* or *failed* status will appear on the screen.

6. Press **Done** to exit the routine, displaying a **Calibration Finished** message.
7. Press the **CLEAR MENU** button.

Performance Tests

This subsection contains procedures to verify that the TAS 475 and TAS 485 Analog Oscilloscopes perform as warranted.

The procedures are arranged in three logical groupings: *Vertical Checks*, *Horizontal Checks*, and *Trigger Checks*. They check all the characteristics that are designated as checked in Section 1, *Specifications*. (The checked characteristics appear in **boldface** type under *Warranted Characteristics* in section 1.)

These procedures *extend* the confidence level provided by the *Brief Performance Checks* in this section.

Performance Tests Prerequisites



The tests in this subsection comprise an extensive, valid confirmation of performance and functionality when the following requirements are met.

- The cabinet must be installed on the oscilloscope.
- The *Power-On Self Tests* show no failures.
- You must have completed the *Temperature Compensation Calibrations*, beginning on page 4-9.
- The oscilloscope must have an operating warm-up period of at least 20 minutes at an ambient temperature between -10°C and $+55^{\circ}\text{C}$.
- Set the **INTENSITY** and **READOUT** controls for nominal viewing levels.
- Set the delayed sweep intensity to **Intensity Delay > Main** in the Utility Configure menu.

Related Information — Read *General Instructions* that start on page 4-1. If you are not familiar with operating this oscilloscope, read Section NO TAG, *Getting Started*, before performing these procedures.

Equipment Required

These procedures use external, traceable signal sources to directly check warranted characteristics. Table 4-1 lists the required test equipment.

Performance Tests

Table 4-1: Test Equipment

Item Number and Description	Minimum Requirements	Example	Purpose
1 Attenuator, 2X ³	Ratio: 2X; Impedance 50 Ω; Connectors: female BNC input, male BNC output	Tektronix part number 011-0069-02	Signal attenuation
2 Attenuator, 10X	Ratio: 10X; Impedance 50 Ω; Connectors: female BNC input, male BNC output	Tektronix part number 011-0059-02	Signal attenuation
3 Termination, 50 Ω	Impedance 50 Ω; Connectors: female BNC input, male BNC output	Tektronix part number 011-0049-01	Signal interconnection
4 Termination, 75 Ω	Impedance 75 Ω; Connectors: female BNC input, male BNC output	Tektronix part number 011-0102-01	Signal interconnection, video
5 Cable, Precision Coaxial	50 Ω, 36 in, male-to-male BNC connectors	Tektronix part number 012-0482-00	Signal interconnection
6 Cable, Coaxial	75 Ω, 36 in, male-to-male BNC connectors	Tektronix part number 012-1338-00	Signal interconnection, video
7 Coupler, Dual-Input (three required)	Female-BNC-to-dual-male-BNC	Tektronix part number 067-0525-02	Signal interconnection
8 Generator, Leveled Sine Wave	200 kHz to 250 MHz; Variable amplitude from 5 mV to 4 V _{p-p} into 50 Ω	TEKTRONIX SG 503 Leveled Sine Wave Generator ¹	Trigger and bandwidth checks
9 Generator, Time Mark	Variable marker frequency from 10 ms to 10 ns; accuracy within 2 ppm	TEKTRONIX TG 501A Time Mark Generator ¹	Timing accuracy checks
10 Generator, Pulse	High Amplitude pulse with variable amplitude of 60 V to 100 V	TEKTRONIX PG 506A Calibration Generator ^{1,2}	Gain accuracy checks
11 Generator, DC Calibration	DC voltage levels from 100 mV to 10 V	TEKTRONIX PG 506A Calibration Generator ^{1,2}	Gain accuracy checks
12 Probe, 10X, included with this instrument	Standard accessory probe	TEKTRONIX P6109B (TAS 475) or TEKTRONIX P6111B (TAS 485)	Signal interconnection
13 Generator, Video Signal	Provides NTSC compatible outputs	TEKTRONIX TSG 100	Video trigger check
14 Adjustment Tool ³	0.1 inch hex on both ends	GC Electronics #8606	Internal adjustments

¹ Requires a TM 500 or TM 5000 Series Power Module Mainframe.² The PG 506A must have the internal Square-Wave/DC switch repositioned depending on the requirements of the procedure.³ This item is used only when performing the Adjustment Procedures.

Vertical System Checks

These procedures check those characteristics that relate to the vertical system and are listed as checked under *Warranted Characteristics* in Section 1, *Specifications*.

Check DC Gain and Voltage Measurement Accuracy

Equipment Required: One pulse generator (item 10) and one precision coaxial cable (item 5).

1. Display the channel to be verified, turning all others off.
2. Press the **AUTOSET** button.
3. Set the sec/div scale to 500 μ s.
4. Press the **TRIGGER MENU** button and set **CPLG** to **Noise Reject**.
5. Press the **CURSOR** button and set Δ **Volt** to **On**.
6. Press the **VERTICAL MENU** button and make the following selections:
 - Set **CPLG** to **DC**
 - Set **BW** to **20 MHz**
7. Set the volts/div scale to 2 mV.
8. Position the trace three divisions below the center horizontal graticule line.
9. Connect the standard amplitude output of the pulse generator to the input of the channel to be verified as shown in Figure 4-6.

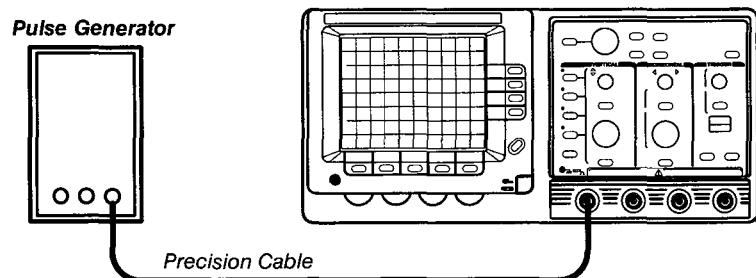

Figure 4-6: Gain and Voltage Test Setup

10. Set the pulse generator for 10 mV amplitude output.
11. Use the General Purpose Knob and **TOGGLE** button to precisely align the cursors to the signal peaks.
12. Check the Displayed Signal Accuracy and Volts Readout Accuracy while setting the Volts/Div Scale and the Input Amplitude given in Table 4-2.

Table 4-2: DC Gain and Delta Volts Accuracy

Volts/Div Scale	Input Amplitude	Displayed Signal Accuracy	Delta Volts Readout Accuracy
2 mV	10 mV	4.87 to 5.13 div	9.80 mV to 10.2 mV
5 mV	20 mV	3.9 to 4.1 div	19.6 mV to 20.4 mV
10 mV	50 mV	4.87 to 5.13 div	49.0 mV to 51.0 mV
20 mV	0.1 V	4.87 to 5.13 div	98.0 mV to 102 mV
50 mV	0.2 V	3.9 to 4.1 div	196 mV to 204 mV
100 mV	0.5 V	4.87 to 5.13 div	490 mV to 510 mV
1 V	5 V	4.87 to 5.13 div	4.90 V to 5.10 V

13. Return the volts/div scale to 2 mV and set the pulse generator for 10 mV amplitude output.
14. Press the **VERTICAL MENU** button and set **VAR** to **On**.
15. Check that rotating the General Purpose Knob counterclockwise reduces the displayed signal amplitude to two divisions or less. Set **VAR** to **Off**.
16. Disconnect the test setup from the oscilloscope.
17. Repeat this procedure until you have verified all input channels.
18. Press the **CURSOR** button and set Δ **Volt** to **Off**.

Check Trigger Level Accuracy

Equipment Required: One DC calibration generator (item 11) and one precision coaxial cable (item 5).

1. Display channel 1, turning all others off.
2. Press the **AUTOSET** button.
3. Set the sec/div scale to 500 μ s.
4. Press the **TRIGGER MENU** button and make the following selections:
 - Set **CPLG** to **DC**
 - Set **SLOPE** to **Rising**
5. Press the **VERTICAL MENU** button and make the following selections:
 - Set **CPLG** to **DC**
 - Set **BW** to **20 MHz**
6. Set the volts/div scale to 50 mV.
7. Position the trace three divisions below the center horizontal graticule line.

8. Connect the DC calibration generator to the **CH 1** input as shown in Figure 4-7.

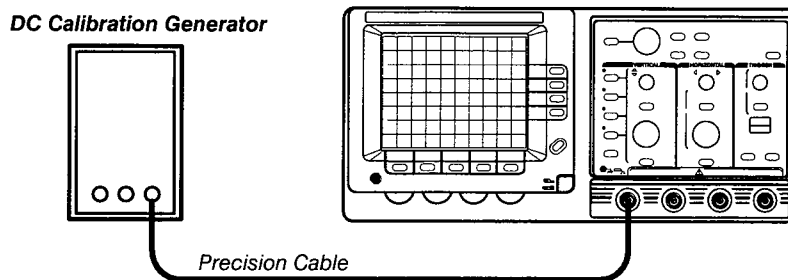

Figure 4-7: Trigger Level Test Setup

9. Set the DC calibration generator for a 200 mV output.
10. Press the **SET LEVEL TO 50%** button.
11. Check that the Trigger Level Accuracy readout is in the range of 169 mV to 231 mV.
12. Press the **TRIGGER MENU** button and set **SLOPE** to **Falling**.
13. Press the **SET LEVEL TO 50%** button.
14. Check that the Trigger Level Accuracy readout is in the range of 169 mV to 231 mV.
15. Press the **MAIN/DELAY SELECT** button, displaying the delay trigger menu.
16. Set **MODE** to **Runs After** and **SRC** to **Ch1**.
17. Press the **SET LEVEL TO 50%** button.
18. Check that the Trigger Level Accuracy readout is in the range of 169 mV to 231 mV.
19. Disconnect the test setup from the oscilloscope.
20. Press the **MAIN/DELAY SELECT** button and set **SLOPE** to **Rising**.
21. Press the **HORIZONTAL MENU** button and set **DELAY** to **Off**.

Check DC Coupling Bandwidth

Equipment Required: One leveled sine wave generator (item 8), one precision coaxial cable (item 5), and one 50 Ω termination (item 3).

1. Display the channel to be verified, turning all others off.
2. Connect the output of the sine wave generator to the channel to be verified as shown in Figure 4-8.

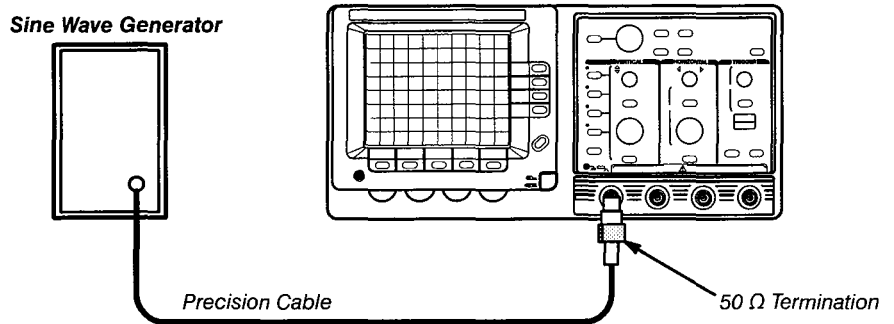

Figure 4-8: Bandwidth Test Setup

3. Press the **AUTOSET** button.
4. Set the volts/div scale to 2 mV.
5. Set the sec/div scale to 200 μ s.
6. Set the sine wave generator for a 50 kHz reference frequency and adjust the amplitude for a six division display.
7. Press the **TRIGGER MENU** button and set **CPLG** to **Noise Reject**.
8. Use the following substeps (a to c) and the settings and limits given in Table 4-3 to confirm the bandwidth of the input channels.
 - a. Set the volts/div scale as indicated.
 - b. Set the signal generator for the specified amplitude at the reference frequency.
 - c. While confirming the Display Amplitude remains greater than the minimum number of divisions, increase the signal generator frequency to 100 MHz or 200 MHz, depending on the instrument model.

Table 4-3: DC Coupled Bandwidth

Volts/Div Scale	50 kHz Reference Amplitude	Display Amplitude	
		TAS 475 To 100 MHz	TAS 485 To 200 MHz
2 mV	6 division	≥ 4.2 division	≥ 4.2 division
5 mV	6 division	≥ 4.2 division	≥ 4.2 division
10 mV	6 division	≥ 4.2 division	≥ 4.2 division
20 mV	6 division	≥ 4.2 division	≥ 4.2 division
50 mV	6 division	≥ 4.2 division	≥ 4.2 division
100 mV	6 division	≥ 4.2 division	≥ 4.2 division
1 V	5 division	≥ 3.5 division	≥ 3.5 division

9. Disconnect the test setup from the oscilloscope.
10. Repeat this procedure until all input channels are verified.

Check X-Axis Gain

Equipment Required: One pulse generator (item 10) and one precision coaxial cable (item 5).

1. Display channel 1, turning all others off.
2. Connect the output of the pulse generator to the **CH 1** input as shown Figure 4-9.

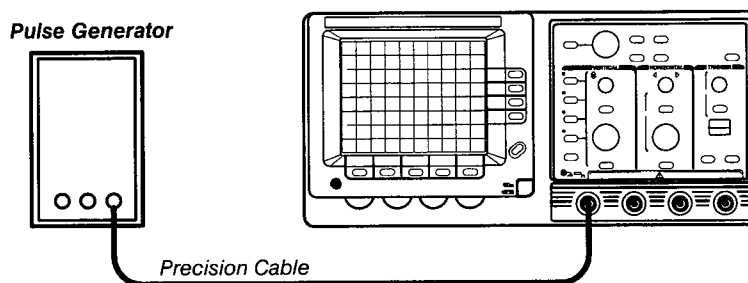

Figure 4-9: X-Axis Gain Test Setup

3. Set the output of the pulse calibration generator for 50 mV.
4. Press the **AUTOSET** button.
5. Set the volts/div scale to 10 mV.
6. Center the display using the vertical **POSITION** control.
7. Press the **HORIZONTAL MENU** button and set **XY** to **On**.
8. Check that the amplitude of the X-axis signal is 4.8 to 5.2 divisions.
9. Set **XY** to **Off**.
10. Disconnect the test setup from the oscilloscope.

Horizontal System Checks

These procedures check those characteristics that relate to the horizontal system and are listed as checked under *Warranted Characteristics* in Section 1, *Specifications*.

Check Time Base and Time Cursor Accuracy

Equipment Required: One time marker generator (item 9), one precision coaxial cable (item 5), and one 50 Ω termination (item 3).

1. Display channel 1, turning all others off.

Performance Tests

2. Connect the output of the time marker generator to the **CH 1** input as shown in Figure 4-10.

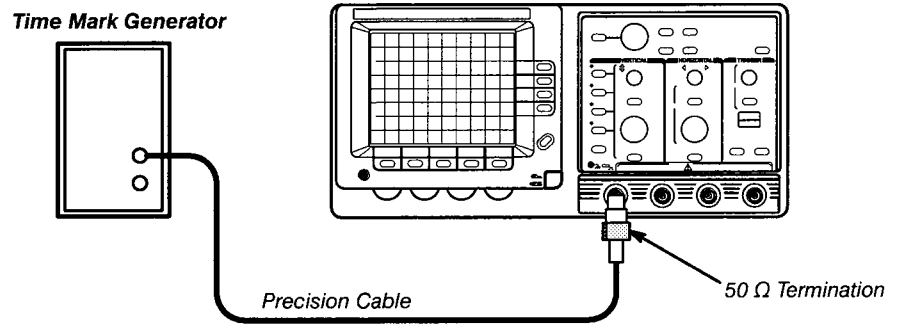

Figure 4-10: Timing Test Setup

3. Set the output of the generator as follows:
 - TAS 475 — 20 ns markers
 - TAS 485 — 10 ns markers
4. Press the **AUTOSET** button.
5. Set the sec/div scale as follows:
 - TAS 475 — 20 ns
 - TAS 485 — 10 ns
6. Set the volts/div scale to 500 mV.
7. Center the time mark display vertically.
8. Press the **CURSOR** button and set Δ **TIME** to **On**.
9. Position the rising edge of the second time mark to the second vertical graticule line.
10. Align the active cursor to the second time mark at the point the rising edge intersects the center horizontal graticule line using the General Purpose Knob.
11. Press the **TOGGLE** button and align the second cursor to the tenth time mark at the point the rising edge intersects the center horizontal graticule line using the General Purpose Knob.
12. Check that the Time-mark to Graticule Accuracy and the Time Cursor Readout Accuracy over the center eight divisions are within the limits shown for each Sec/Div Scale listed in Table 4-4.

Table 4-4: Time Base and Cursor Accuracies (Mag Off)

Sec/Div Scale (Mag Off)	Time Mark Setting	Time-mark to Graticule Accuracy	Time Cursor Readout Accuracy
		Over Center 8 Divisions	2nd and 10th Time Marks
10 ns ¹	20 ns	±0.16 division	78.4 ns to 81.6 ns
20 ns	20 ns	±0.16 division	157 ns to 163 ns
50 ns	50 ns	±0.16 division	392 ns to 408 ns
100 ns	0.1 μs	±0.16 division	784 ns to 816 ns
200 ns	0.2 μs	±0.16 division	1.57 μs to 1.63 μs
500 ns	0.5 μs	±0.16 division	3.92 μs to 4.08 μs
1 μs	1 μs	±0.16 division	7.84 μs to 8.16 μs
2 μs	2 μs	±0.16 division	15.7 μs to 16.3 μs
5 μs	5 μs	±0.16 division	39.2 μs to 40.8 μs
10 μs	10 μs	±0.16 division	78.4 μs to 81.6 μs
20 μs	20 μs	±0.16 division	157 μs to 163 μs
50 μs	50 μs	±0.16 division	392 μs to 408 μs
100 μs	0.1 ms	±0.16 division	784 μs to 816 μs
200 μs	0.2 ms	±0.16 division	1.57 ms to 1.63 ms
500 μs	0.5 ms	±0.16 division	3.92 ms to 4.08 ms
1 ms	1 ms	±0.16 division	7.84 ms to 8.16 ms
2 ms	2 ms	±0.16 division	15.7 ms to 16.3 ms
5 ms	5 ms	±0.16 division	39.2 ms to 40.8 ms

¹The 10 ns sec/div scale is only available on the TAS 485.

13. Set **ΔTIME** to **Off**.
14. Set the time mark generator as follows:
 - TAS 475 — 20 ns markers
 - TAS 485 — 10 ns markers
15. Set the main sec/div scale as follows:
 - TAS 475 — 20 ns
 - TAS 485 — 10 ns
16. Press the **HORIZONTAL MENU** button and set **DELAY** to **On** and **MAIN** to **Off**.

17. Set the delayed sec/div scale as follows:
 - TAS 475 — 20 ns
 - TAS 485 — 10 ns
18. Using the General Purpose Knob, set the delay time as follows:
 - TAS 475 — 3 ns
 - TAS 485 — 1.5 ns
19. Position the edge of the second time mark to the second vertical graticule line.
20. Check that the Time Mark to Graticule Accuracy over the center eight divisions are within the limits shown for each sec/div scale listed in Table 4-4 (disregard the Time Cursor Readout Accuracy column).
21. Set **MAIN** to **On**.
22. Set the main sec/div scale as follows:
 - TAS 475 — 20 ns
 - TAS 485 — 10 ns
23. Set **MAIN** to **Off**.
24. Press the **MAG** button, turning magnification on.
25. Set the time mark generator for 5 ns markers.
26. Set the volts/div scale to 200 mV.
27. Check that the timing accuracies at the beginning, middle, and end of sweep over the center eight divisions are within the limits shown for each of the sec/div scales given in Table 4-5. Exclude the first and last five divisions of the magnified sweep for accuracy measurements.

Table 4-5: Time Base Accuracy (Mag On)

Sec/Div Scale (Mag On)	Time Marker Setting	Time Mark to Graticule Over Center 8 Divisions
1 ns ⁴	5 ns ¹	±0.24 division ³
2 ns	5 ns ¹	±0.24 division ²
5 ns	5 ns ¹	±0.24 division
10 ns	10 ns	±0.24 division
100 ns	0.1 μs	±0.24 division
100 μs	0.1 ms	±0.24 division

¹ Change the volts/div scale as necessary to maintain vertical amplitude.

² At this setting, two cycles of the signal are displayed for every five horizontal divisions.

³ At this setting, one cycle of the signal is displayed for every five horizontal divisions.

⁴ The 1 ns sec/div scale is only available on the TAS 485.

28. Set **MAIN** to **On** and **DELAY** to **Off**.
29. Set the sec/div scale as follows:
 - TAS 475 — 2 ns
 - TAS 485 — 1 ns
30. Set the time mark generator for 5 ns markers.
31. Check that the timing accuracies at the beginning, middle, and end of sweep over the center eight divisions are within the limits shown for each Sec/Div Scale given in Table 4-5. Exclude the first and last five divisions of the magnified sweep for accuracy measurements.
32. Press the **MAG** button, turning magnification off.

Check Dual Delay Accuracy

Equipment Required: One time marker generator (item 9), one precision coaxial cable (item 5), and one 50 Ω termination (item 3).

1. Display channel 1, turning all others off.
2. Connect the output of the time marker generator to the **CH 1** input as shown in Figure 4-11.

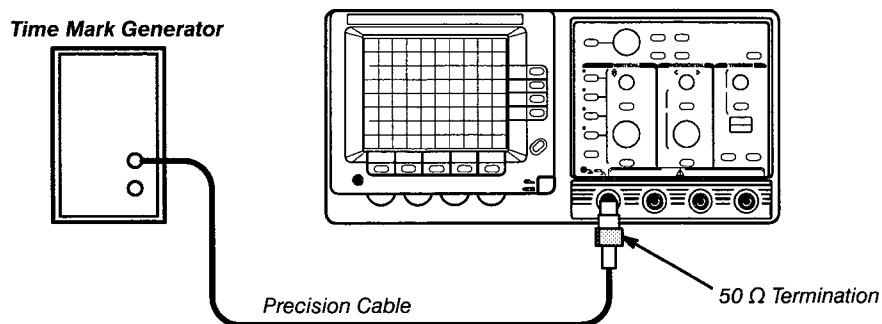

Figure 4-11: Dual Delay Test Setup

3. Set the output of the time marker generator for 0.5 ms markers.
4. Press the **AUTOSET** button.
5. Set the sec/div scale to 500 μ s.
6. Set the volts/div scale to 500 mV.
7. Position the time marker display to the upper half of the graticule and align the first time marker to the second vertical graticule line.
8. Press the **TRIGGER MENU** button and then the **MAIN/DELAY SELECT** button.
9. Set **MODE** to **Runs After**.
10. Set the delayed sec/div scale to 50 μ s.

11. Press **HORIZONTAL MENU**.
12. Select **TRCSEP** and position the delayed time marker display to the lower half of the graticule using the General Purpose Knob.
13. Select **DELAY**.
14. Using the General Purpose Knob, position the intensified zone on the main sweep to the second time marker; then, slightly adjust the General Purpose Knob until the delayed sweep time marker is at the graticule center.
15. Press the **UTILITY** button and select **CONFIG** from the main menu.
16. Select **MORE** until you can select **Dual Delay Enabled** from the sub menu.
17. Press the **CURSOR** button and set Δ **TIME** to **On**.
18. Using the General Purpose Knob, position the second intensified zone on the main sweep to the third time marker; then, slightly adjust the General Purpose Knob to superimpose the delayed sweep time markers at the graticule center. Press the **TOGGLE** button to assign the General Purpose Knob to the second intensified zone if necessary.
19. Check the Dual Delay Accuracy Reading for each time marker pair listed in Table 4-6.

Table 4-6: 500 μ s Dual Delay Accuracy

Time Markers Intensified	Dual Delay Accuracy Reading Limits
Second and third	473 μ s to 527 μ s
Second and fourth	970 μ s to 1.03 ms
Second and sixth	1.97 ms to 2.03 ms
Second and tenth	3.96 ms to 4.04 ms

20. Press the **MAIN/DELAY SELECT** button and set the main sec/div scale to 200 ns.
21. Press the **MAIN/DELAY SELECT** button and set the delayed sec/div scale to 20 ns.
22. Set the time mark generator for 0.2 μ s markers.
23. Using the General Purpose Knob, position the second intensified zone on the main sweep to the tenth time marker; then, slightly adjust the General Purpose Knob to superimpose the delayed sweep time markers at the graticule center.
24. Check the dual delay accuracy (Δ Time) reading is in the range of 1.58 μ s to 1.62 μ s.
25. Press the **CURSOR** button and set Δ **TIME** to **Off**.

26. Press the **UTILITY** button and select **Dual Delay Disabled**.
27. Press the **HORIZONTAL MENU** button and set **DELAY** to **Off**
28. Disconnect the test setup from the oscilloscope.

Trigger System Checks

These procedures check those characteristics that relate to the trigger system and are listed as checked under *Warranted Characteristics* in Section 1, *Specifications*.

Check Trigger Sensitivity

Equipment Required: One sine wave generator (item 8), one 10X attenuator (item 2), one precision coaxial cable (item 5), one dual-input coupler (item 7), and one 50 Ω termination (item 3).

Low Frequency — The following steps check trigger sensitivity at 25 MHz.

1. Display channel 1, turning all others off.
2. Connect the output of the sine wave generator to the **CH 1** input as shown in Figure 4-12.

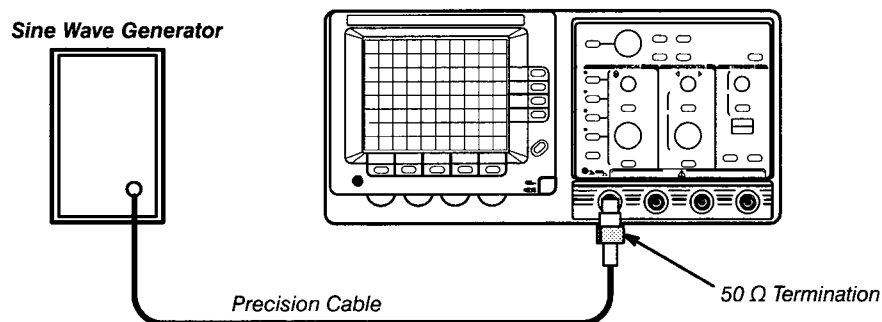

Figure 4-12: Trigger Sensitivity Test Setup One

3. Set the frequency of the sine wave generator to 25 MHz.
4. Press the **AUTOSET** button.
5. Set the volts/div scale to 50 mV.
6. Set the sec/div scale to 100 ns.
7. Press the **VERTICAL MENU** button and set **CPLG** to **DC**

8. Press the **TRIGGER MENU** button and make the following selections from the main trigger menu:
 - Set **MODE** to **Auto**
 - Set **SRC** to **Ch1**
 - Set **CPLG** to **DC**
 - Set **SLOPE** to **Rising**
9. Press the **MAIN/DELAY SELECT** button and make the following selections from the delay trigger menu:
 - Set **MODE** to **Runs After**
 - Set **SRC** to **Ch1**
 - Set **CPLG** to **DC**
 - Set **SLOPE** to **Rising**
10. Set the delayed sec/div scale to 50 ns.
11. Press the **HORIZONTAL MENU** button and select **DELAY**.
12. Set the delay time to 15 ns using the General Purpose Knob.
13. Set **DELAY** to **Off**.
14. Adjust the sine wave generator amplitude for a three division display.
15. Add a 10X attenuator to the test setup as shown in Figure 4-13.

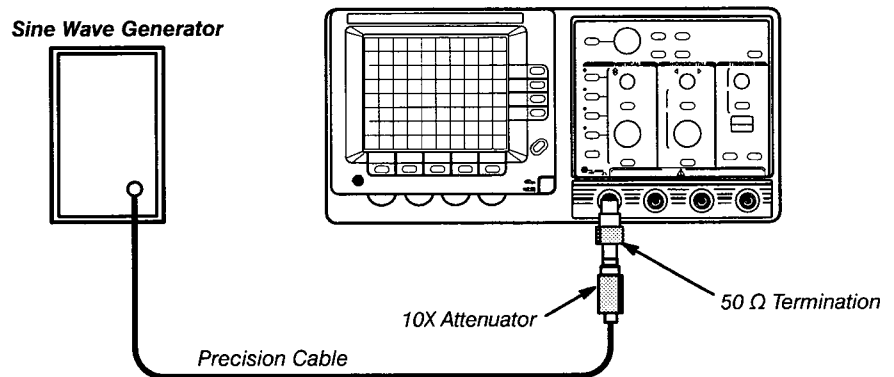

Figure 4-13: Trigger Sensitivity Test Setup Two

16. Press the **SET LEVEL TO 50%** button and confirm a stable display.
17. Press the **TRIGGER MENU** button and set **SLOPE** to **Falling**.
18. Press the **SET LEVEL TO 50%** button and confirm a stable display.
19. Press the **HORIZONTAL MENU** button and set **DELAY** to **On**.
20. Select **TRCSEP** and position the delayed sweep below the main sweep using the General Purpose Knob.

21. Press the **TRIGGER MENU** button and set **MODE** to **Trig After**.
22. Press the **SET LEVEL TO 50%** button and confirm a stable delayed sweep display.
23. Set **SLOPE** to **Falling**.
24. Press the **SET LEVEL TO 50%** button and confirm a stable delayed sweep display.
25. Press the **HORIZONTAL MENU** button and set **DELAY** to **Off**.

High Frequency — The following steps check trigger sensitivity at 150 MHz (TAS 475) or 250 MHz (TAS 485).

1. Remove the 10X attenuator from the test setup. Reconnect as shown in Figure 4-14.

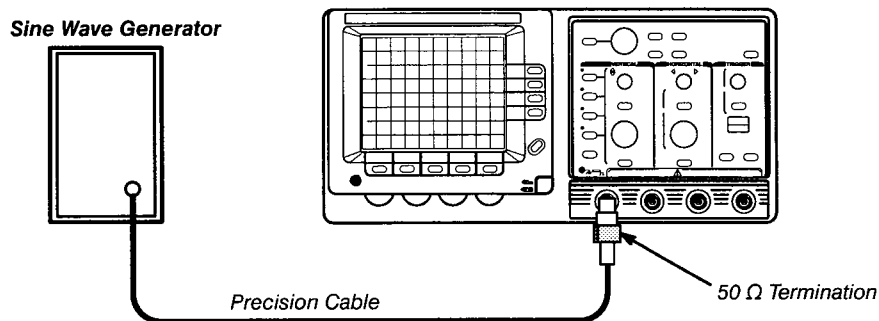

Figure 4-14: Trigger Sensitivity Test Setup Three

2. Set the sine wave generator frequency as follows:
 - TAS 475 — 150 MHz
 - TAS 485 — 250 MHz
3. Press the **MAG** button.
4. Set the volts/div scale to 50 mV.
5. Adjust the sine wave generator amplitude as follows:
 - TAS 475 — adjust for a one division display
 - TAS 485 — adjust for a 1.5 division display
6. Press the **SET LEVEL TO 50%** button and confirm a stable display.
7. Set **SLOPE** to **Rising**.
8. Press the **SET LEVEL TO 50%** button and confirm a stable display.
9. Press the **MAIN/DELAY SELECT** button (selecting delay).
10. Press the **SET LEVEL TO 50%** button and confirm a stable delayed sweep display (see the following note).

NOTE

*A slight adjustment of the delay time may be necessary to obtain a stable delayed sweep display. Press the **Horizontal Menu** button and adjust the delay time using the General Purpose Knob. Press the **Trigger Menu** button after confirming a stable display.*

11. Set **SLOPE** to **Rising**.
12. Press the **SET LEVEL TO 50%** button and confirm a stable delayed sweep display.

NOTE

*A slight adjustment of the delay time may be necessary to obtain a stable delayed sweep display. Press the **Horizontal Menu** button and adjust the delay time using the General Purpose Knob.*

13. Press the **HORIZONTAL MENU** button and set **DELAY** to **Off**.
14. Disconnect the test setup from the oscilloscope.

Video Trigger — The following steps check the video trigger sensitivity.

Equipment Required: One NTSC Television signal generator (item 13), one 75 Ω termination (item 4), and one 75 Ω coaxial cable (item 6).

1. Display channel 1, turning all others off.
2. Connect the composite sync output of the television signal generator to the **CH 1** input as shown in Figure 4-15.

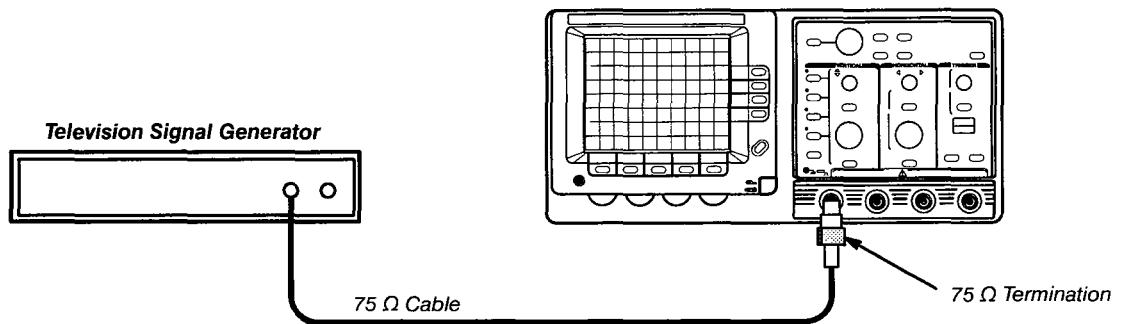

Figure 4-15: Video Trigger Test Setup

3. Press the **AUTOSET** button.
4. Set the volts/div scale to 200 mV.
5. Set the sec/div scale to 100 μ s.
6. Press the **UTILITY** button and select **CONFIG**.

7. Select **MORE** until you can select **Video Sync Negative** from the sub menu.
8. Press the **TRIGGER MENU** button and make the following selections:
 - Set **MODE** to **Video Field <odd>**
 - Set **SLOPE** to **Falling**
9. Confirm a stable display of the video field.
10. Set **MODE** to **Video Field <even>**.
11. Confirm a stable display of the video field.
12. Disconnect the test setup from the oscilloscope.

Adjustment Procedures

This section contains information needed to adjust the TAS 475 and TAS 485 Analog Oscilloscopes.

Description — The *Adjustment Procedures* are divided into two parts:

- General information about adjusting the oscilloscope
- Written procedures for oscilloscope calibration

Purpose — Use this procedure to return the oscilloscope to conformance with its *Warranted Characteristics* as listed in Section 1, *Specifications*. It also optimizes the performance of the oscilloscope.

This procedure is *not* required to verify the oscilloscope conforms with its warranted characteristics. Performance verification procedures are found in Section 4, *Performance Verification*.

Adjustment Interval — As a general rule, perform these adjustments after every 2,000 hours of operation or once a year if used infrequently.

Requirements for Performance

Before you perform this procedure, you need to address the following requirements.

Personnel

This procedure is only to be performed by trained service technicians.

Access to Adjustments

The cabinet must be removed to perform the adjustment procedure. Refer to Section 6, *Maintenance*, for procedures to remove the cabinet. The adjustment procedures make references to adjustments located on internal circuit boards. Figure 5-1 shows the location of each board with adjustments. The end of this section contains figures that show the location of each adjustment for each circuit board.

Warm-Up Period

This oscilloscope requires a 20 minute warm-up period in a 20° C to 30° C environment before performing this adjustment procedure. Adjustments performed before the operating temperature has stabilized may cause errors in performance.

Adjustment Procedures

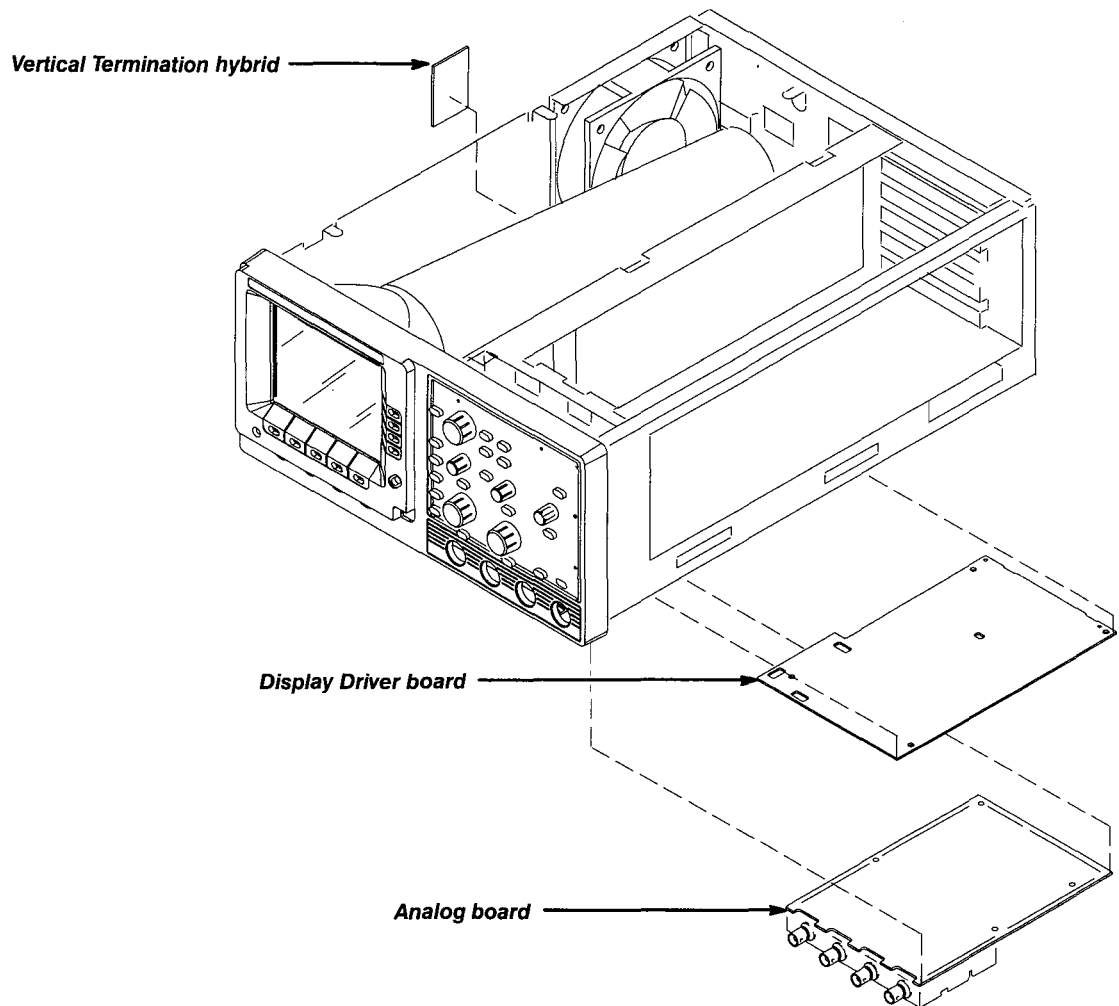

Figure 5-1: Location of Boards for Adjustments

Equipment Required

These procedures use external, traceable signal sources to calibrate the TAS 475 and TAS 485 Oscilloscopes. Table 4-1 on page 4-14 lists all the test equipment required for these procedures.

Performing the Adjustment Procedures

The following topics cover what is required to adjust the oscilloscope. Also, the performance of individual adjustments is discussed.

The **Factory Horizontal Cal** and **Factory Vertical Cal** calibration routines are selected from the Utility menu of the oscilloscope. These routines use both front-panel controls and external standards you provide in response to instructions displayed on the CRT readout.

Complete Adjustment

A complete adjustment consists of a sequence of individual calibration steps performed in the order shown:

1. CRT Adjustment
2. Low Frequency Output Compensation
3. Factory Horizontal Cal
4. Factory Vertical Cal
5. High Frequency Step Response Adjustment
6. Attenuator Compensation
7. Vertical Gain Adjustment

Partial Adjustment

The Adjustment Procedures allow you to make individual adjustments of the steps outlined above; however, usually all adjustment steps are made. Read the information under *Adjustment Dependencies* that follows before performing an individual adjustment.

Adjustment Dependencies

Some adjustments depend on the successful prior completion of other adjustments. Generally, the procedures should be performed in the order shown under *Complete Adjustment*. Some adjustments do not depend on completion of other adjustments. Table 5-1 lists the adjustments and their dependencies.

Table 5-1: Adjustments and Dependencies

Adjustment	Prior Completion Requirements
CRT Adjustment	None
Low Frequency Output Compensation	None
Factory Horizontal Cal	CRT Adjustment
Factory Vertical Cal	Low Frequency Output Compensation and Factory Horizontal Cal
High Frequency Step Response	Factory Vertical Cal
Attenuator Compensation	Low Frequency Output Compensation
Vertical Gain Adjustment	Low Frequency Output Compensation, Factory Vertical Cal, and Attenuator Compensation

Adjustment Instructions

The following instructions will guide you through each of the adjustments outlined in *Complete Adjustments*. Each adjustment section lists all necessary equipment required to perform the adjustments.

CRT Adjustments

Equipment Required: One time marker generator (item 9), one precision coaxial cable (item 5), and one 50 Ω termination (item 3).

Adjustment Locations: This procedure requires adjustments to the Display Driver board. See Figures 5-14 and 5-15 on pages 5-18 and 5-19 for the location of the adjustments.

1. Disconnect all signal inputs from the oscilloscope.
2. Display channel 1, turning all others off.
3. Press the **AUTOSET** button.
4. Set the volts/div scale to 50 mV.
5. Set the sec/div scale to 2 μ s.
6. Press the **VERTICAL MENU** button and make the following selections from the menu:
 - Set **CPLG** to **GND**
 - Set **BW** to **20 MHz**
7. Position the channel 1 trace to the center horizontal graticule line and adjust the **FOCUS** control for a well-defined display.
8. Adjust the **TRACE ROTATION** control (screw-driver adjustment) to align the trace with the center horizontal graticule line.
9. Press the **HORIZONTAL MENU** button and set **XY** to **On**.
10. Set the **INTENSITY** control fully counterclockwise (off).
11. Adjust R322 on the Display Driver board until the dot is visible, then re-adjust R322 until the dot just extinguishes.
12. Set **XY** to **Off**.
13. Connect the output of the time mark generator to the **CH 1** input as shown in Figure 5-2.

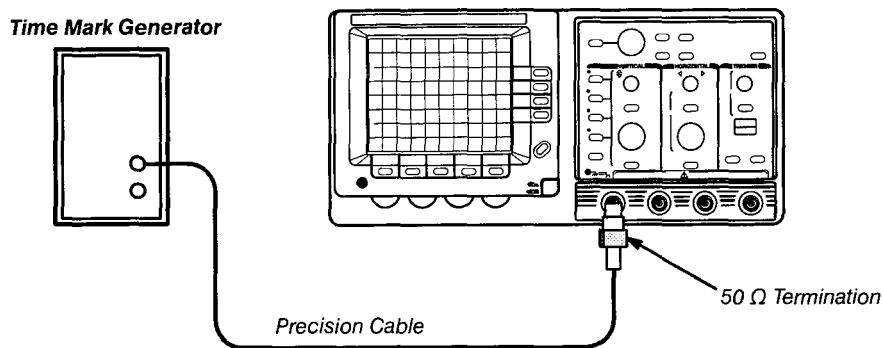

Figure 5-2: CRT Adjustments Calibration Setup

14. Set the time mark generator for 1 μ s markers.
15. Set the **INTENSITY** control to view the display.
16. Press the **VERTICAL MENU** button and set **CPLG** to **DC**
17. Press the **SET LEVEL TO 50%** button.
18. Adjust the **FOCUS** and R321 on the Display Driver board for the best focus of the time mark display and readout display.
19. Set the vertical **POSITION** control counterclockwise, moving the baseline of the time mark display down off the graticule area.
20. Set the **READOUT INTENSITY** control fully counterclockwise (off).
21. Adjust R323 on the Display Driver for the best geometry (minimum bowing) of the time mark display across the entire graticule area.
22. Set the **READOUT INTENSITY** control to view the readout.
23. Disconnect the calibration setup from the oscilloscope.

Low Frequency Output Compensation

Equipment Required: One pulse generator (item 10), one precision coaxial cable (item 5), one 50 Ω termination (item 3), and one dual-input coupler (item 7).

Adjustment Locations: This procedure requires adjustments to the Display Driver board. See Figures 5-14 and 5-15 on pages 5-18 and 5-19 for the location of the adjustments.

1. Display channel 1, turning all others off.
2. Press the **AUTOSET** button.
3. Set the volts/div scale to 50 mV.
4. Set the sec/div scale to 1 ms.
5. Press the **ALT/CHOP, ADD** button and set **DISP** to **Alt**.

Adjustment Procedures

6. Press the **VERTICAL MENU** button and set **CPLG** to **AC**.
7. Connect the positive fast rise pulse output of the pulse generator to the **CH 1** and **CH 2** input connectors as shown in Figure 5-3.

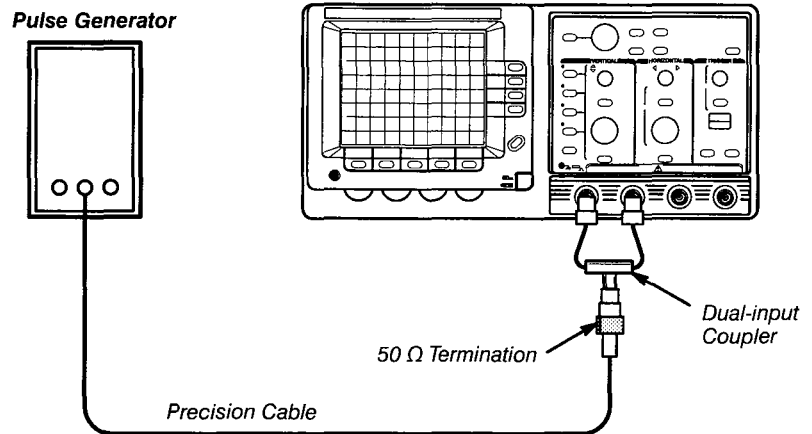

Figure 5-3: Low Frequency Output Compensation Calibration Setup

8. Set the pulse generator for fast rise period of 1 ms and a 4 division display.
9. Press the **SET LEVEL TO 50%** button.
10. Press the **CURSOR** button and set Δ VOLT to **On**.
11. Set the cursors 5 divisions apart using the General Purpose Knob and the **TOGGLE** button.
12. Set the volts/div scale to 20 mV.
13. Press the **CH 2** button.
14. Set the channel 2 volts/div scale to 20 mV.
15. Press the **VERTICAL MENU** button and make the following selections from the menu (channel 2):
 - Set **CPLG** to **GND**
 - Set **VAR** to **Off**
 - Set **INV** to **Off**
 - Set **BW** to **Full**
16. Position the channel 2 trace to the center vertical graticule line.
17. Set **CPLG** to **AC**.
18. Adjust R111 located on the Display Driver board for minimum vertical movement of the readout (over the entire graticule area).
19. Disconnect the test setup from the oscilloscope.

Factory Horizontal Cal

Equipment Required: One time mark generator (item 9), one precision coaxial cable (item 5), and one 50 Ω termination (item 3).

Prerequisites: CRT adjustment procedure.

1. Disconnect all signal inputs from the oscilloscope.
2. Press the **UTILITY** button to display the Utility menu.
3. Select **CAL** from the main menu.
4. Select **Factory Horizontal Cal**, initiating the calibration routine.

This routine takes about 20 seconds to complete its initial calibrations. Once complete, 2 dots are displayed and the message "**Toggle to set 8div about center**" appears. The displayed dots are used for the next horizontal calibration steps.

NOTE

*The following steps use both the General Purpose Knob and the **TOGGLE** button to make adjustments. The General Purpose Knob performs two functions: to adjust horizontal gain and centering. The **TOGGLE** button selects the function of the General Purpose Knob.*

5. Use a combination of the **TOGGLE** button and the General Purpose Knob to position the dots 8 divisions apart, centered horizontally (see Figure 5-4).
6. Select **Done** when you have the appropriate display.

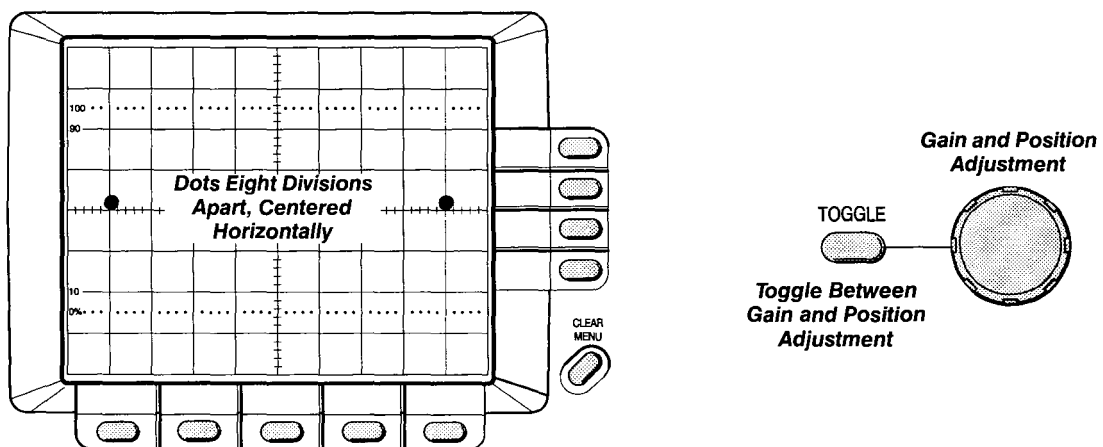

Figure 5-4: Horizontal Adjustments

7. Again, use a combination of the **TOGGLE** button and the General Purpose Knob to position the dots 8 divisions apart, centered horizontally (see Figure 5-4).

Adjustment Procedures

8. Select **Done** when you have the appropriate display.
9. One dot is displayed.
10. Use a combination of the **TOGGLE** button and the General Purpose Knob to center the single dot at the center of the screen (see Figure 5-5).

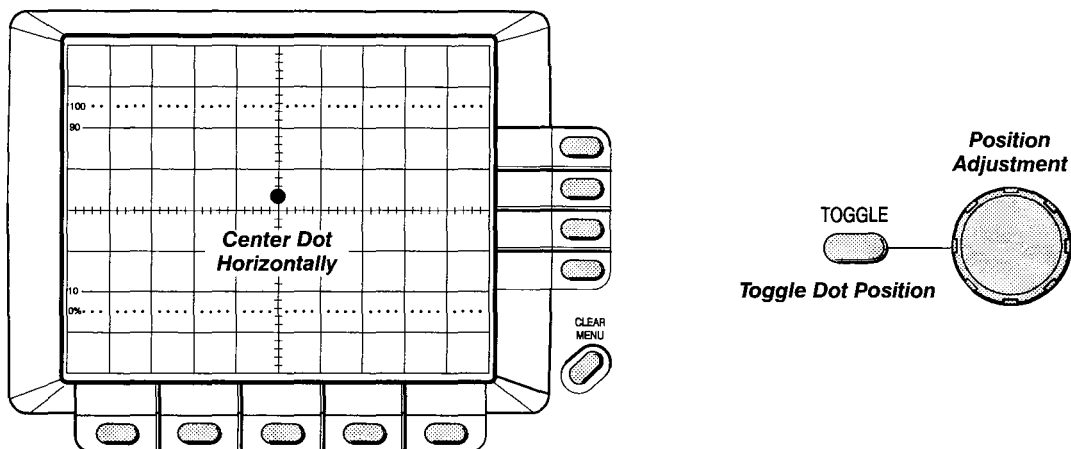

Figure 5-5: Horizontal Adjustments

11. Continue to press the **TOGGLE** button and adjusting the dot to center screen with the General Purpose Knob until the dot stays centered while pressing the **TOGGLE** button.
12. Select **Done** when you have the appropriate display.
13. Two vertical cursor lines are displayed.
14. Use a combination of the **TOGGLE** button and the General Purpose Knob to position the vertical lines 8 divisions apart, centered horizontally (see Figure 5-6).

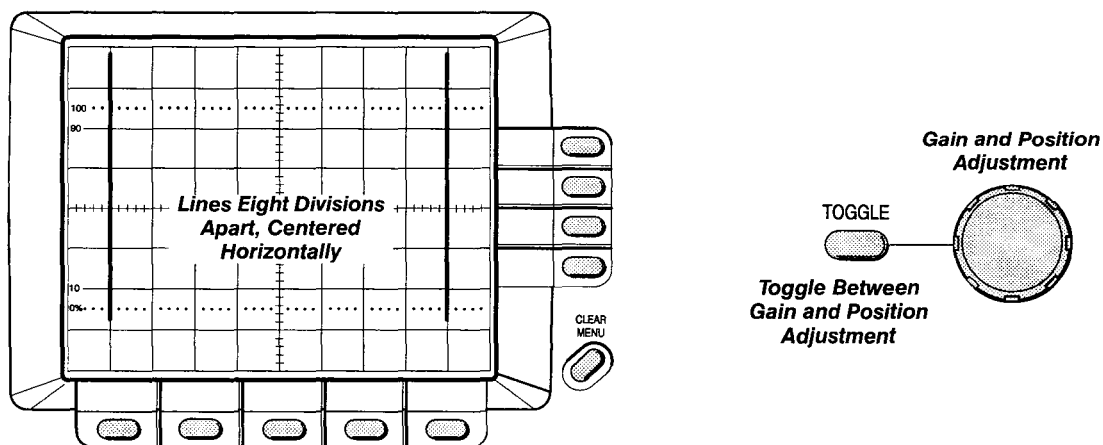

Figure 5-6: Horizontal Adjustments

15. Select **Done** with the menu button when you have the appropriate display.

NOTE

*At this time, the calibration routine can be terminated by selecting **Abort** instead of **Done**. The abort option appears through the remainder of this Factory Horizontal Cal routine.*

16. Select **Done** to continue or **Abort** to terminate the calibration routine.
17. Connect the output of the time mark generator to the **CH 1** input as shown in Figure 5-7.

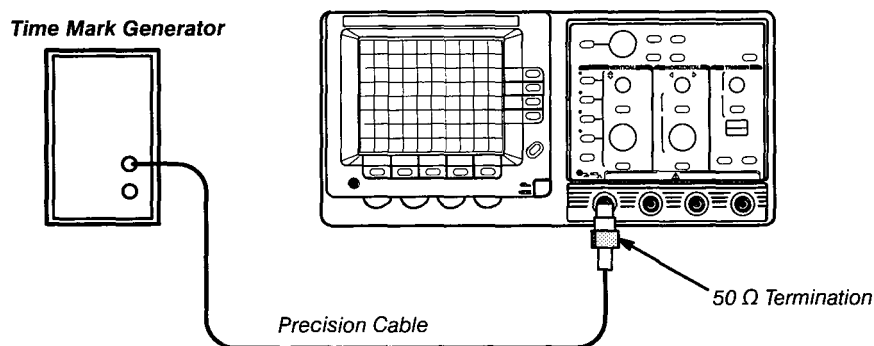

Figure 5-7: Horizontal Output Calibration Setup

18. Set the time mark generator for 5 ns markers.
19. Select **Done** when completed.
20. Adjust the 2 ns main sweep accuracy by performing these substeps.
 - a. Using the General Purpose Knob, adjust the display for 2 time markers per 5 divisions over the center 8 divisions.
 - b. Select **Done** when adjusted.
21. Adjust the 2 ns delay sweep accuracy by performing these substeps.
 - a. Using the General Purpose Knob, adjust the display for 2 time markers per 5 divisions over the center 8 divisions.
 - b. Select **Done** when adjusted. If adjusting the TAS 475, a **Cal Passed** message appears and you can skip to step 24. If adjusting the TAS 485 continue this procedure.
22. **TAS 485 Only** — Adjust the 1 ns main sweep accuracy by performing these substeps.
 - a. Using the General Purpose Knob, adjust the display for 2 time markers per 8 divisions over the center 8 divisions.
 - b. Select **Done** when adjusted.

23. **TAS 485 Only** — Adjust the 1 ns delay sweep accuracy by performing these substeps.
 - a. Using the General Purpose Knob, adjust the display for 2 time markers per 8 divisions over the center 8 divisions.
 - b. Select **Done** when adjusted; a **Cal Passed** message appears.
24. Select **Done** to exit the routine.
25. Disconnect the test setup from the oscilloscope.

Factory Vertical Cal

Equipment Required: One DC calibration generator (item 11), one precision coaxial cable (item 5), and three dual-input couplers (item 7).

Prerequisites: Low Frequency Output Compensation adjustment and Self Cal Horizontal adjustment procedures.

1. Press the **UTILITY** button.
2. Select **CAL** from the main menu.
3. Select **Factory Vertical Cal**, initiating the calibration routine.

The calibration routine displays user prompts on-screen throughout this procedure.

NOTE

*At this time, the calibration routine can be terminated by selecting **Abort**. The abort option appears through the remainder of this Factory Vertical Cal routine.*

4. Set the DC calibration generator for 10 VDC output and connect to the **CH 1**, **CH 2**, **CH 3**, and **CH 4** inputs as shown in Figure 5-8.

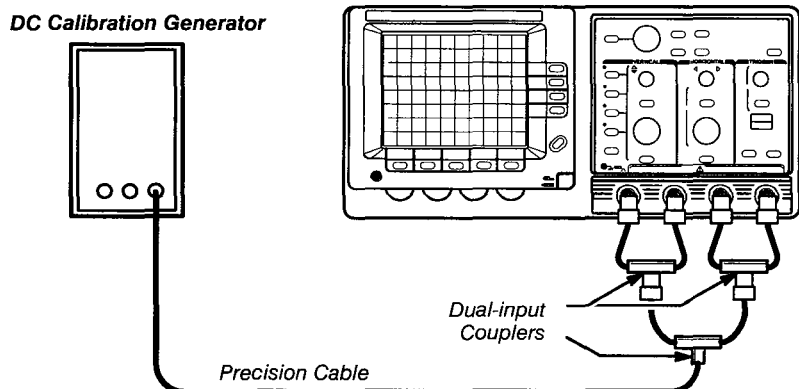

Figure 5-8: Factory Vertical Calibration Setup

5. Select **Done** when completed.

6. Set the DC calibration generator for 1 VDC output.
7. Select **Done** when completed.
8. Set the DC calibration generator for 100 mVDC output.
9. Select **Done** when completed.
10. Disconnect the test setup.
11. Select **Done** when completed.

This portion of the routine takes less than two minutes to complete.

NOTE

*The following steps use both the General Purpose Knob and the **TOGGLE** button to make adjustments. The General Purpose Knob performs two functions: adjust horizontal gain and centering. The **TOGGLE** button selects the function of the General Purpose Knob.*

12. Use a combination of the **TOGGLE** button and the General Purpose Knob to position the dots 6 divisions apart, centered horizontally (see Figure 5-9).

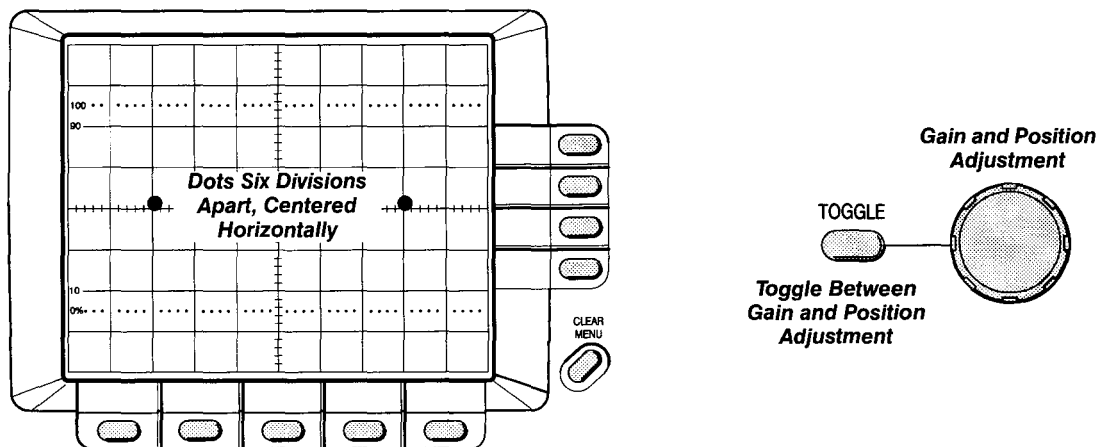

Figure 5-9: Vertical Adjustments

13. Select **Done** when you have the appropriate display.
14. Adjust R112 (vertical gain) and R154 (vertical centering) on the Display Driver board, setting the horizontal cursors 6 divisions apart, centered vertically (see Figure 5-10).

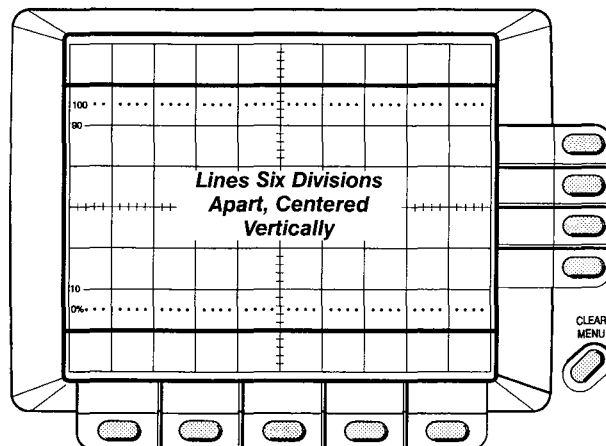

Figure 5-10: Adjusting Vertical Gain and Centering

15. Select **Done** when you have completed the adjustments.
16. Select **Done** again to exit the routine.

High Frequency Step Response

Equipment Required: One pulse generator (item 10), one precision coaxial cable (item 5), one 2X attenuator (item 1), and one 50 Ω termination (item 3).

Adjustment Locations: This procedure requires adjustments to the Display Driver board and the Vertical Termination hybrid. See Figures 5-14 and 5-15 on pages 5-18 and 5-19 for the location of the Display Driver board adjustments. See Figure 5-13 on page 5-17 for the location of the Vertical Termination hybrid adjustment.

Prerequisites: Factory Vertical Cal adjustment procedure.

1. Display channel 1, turning all others off.
2. Connect the positive fast rise pulse output of the pulse generator to the **CH 1** input as shown in Figure 5-11.

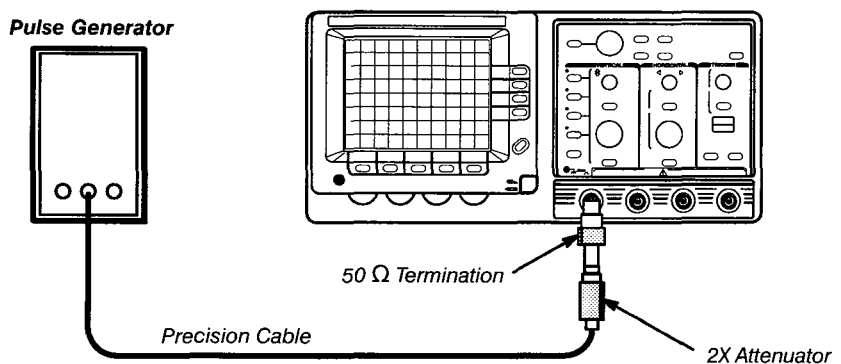

Figure 5-11: High Frequency Step Response Test Setup

3. Set the pulse generator fast rise period to 1 μ s and pulse amplitude to mid-range.
4. Press the **AUTOSET** button.
5. Use the following substeps to adjust the TAS 475. If adjusting the TAS 485, proceed to step 6.
 - a. Set the volts/div scale to 10 mV.
 - b. Set the sec/div scale to 200 ns.
 - c. Press the **VERTICAL MENU** button and set **CPLG** to **DC**.
 - d. Adjust the vertical **POSITION** control and the generator pulse amplitude to obtain a 5 division, vertically centered, display.
 - e. Adjust R141 and C122 on the Display Driver board for flattest long term response of the pulse front corner.
 - f. Set the sec/div scale to 20 ns.
 - g. Adjust R140 and C121 on the Display Driver board for minimum signal aberrations of the pulse front corner.

NOTE

Some interaction of the adjustments made in steps e through g may occur. For optimum oscilloscope performance, these steps should be rechecked after making adjustments.

6. Use the following substeps to adjust the TAS 485.
 - a. Set the volts/div scale to 100 mV.
 - b. Set the sec/div scale to 200 ns.
 - c. Press the **VERTICAL MENU** button and set **CPLG** to **DC**.
 - d. Adjust the vertical **POSITION** control and the generator pulse amplitude to obtain a 5 division, vertically centered, display.
 - e. Adjust R141 and C122 on the Display Driver board for flattest long term response of the pulse front corner.
 - f. Adjust R142 on the Display Driver board for flattest long term response of the pulse front corner.
 - g. Set the sec/div scale to 20 ns.
 - h. Adjust R140 and C121 on the Display Driver board for 1 minor graticule division of signal aberrations on the pulse front corner.
 - i. Adjust the termination on the Vertical Termination hybrid for flattest long term response of the pulse front corner.

NOTE

The position of the leads from the Vertical Termination hybrid to the CRT affect the high frequency step response. Unless the leads have been repositioned, it may not be necessary to adjust them.

Some interaction of the adjustments made in steps e through i may occur. For optimum oscilloscope performance, these steps should be rechecked after making adjustments.

7. Disconnect the calibration setup from the oscilloscope.

Attenuator Compensation

Equipment Required: One pulse generator (item 10), one precision coaxial cable (item 5), one 50 Ω termination (item 3), and three dual-input couplers (item 7).

Adjustment Locations: This procedure requires adjustments to the Analog board. See Figure 5-16 on page 5-20 for the location of the adjustments.

Prerequisites: Low Frequency Output Compensation adjustment procedure.

1. Display channel 1, turning all others off.
2. Connect the high amplitude output of the pulse generator to the **CH 1**, **CH 2**, **CH 3**, and **CH 4** inputs as shown in Figure 5-12.

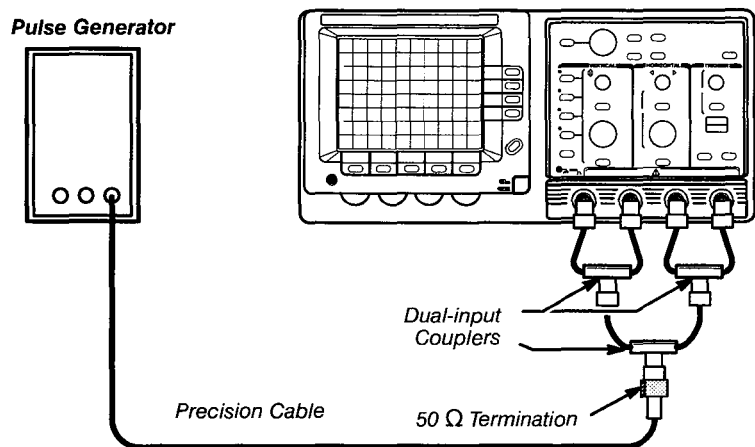

Figure 5-12: Attenuator Compensation Test Setup

3. Set the pulse generator high amplitude period to 1 ms.
4. Press the **AUTOSET** button.
5. Press the **VERTICAL MENU** button and set **CPLG** to **DC**.

6. Set the volts/div scale to 200 mV.
7. Set the sec/div scale to 200 μ s.
8. Using the vertical **POSITION** control and the generator pulse amplitude, obtain a 5 division, vertically centered display of channel 1.
9. Set the volts/div scale to 100 mV.
10. Press the **CH 2** button.
11. Press the **VERTICAL MENU** button and make the following selections from the menu:
 - Set **CPLG** to **DC**
 - Set **VAR** to **Off**
 - Set **INV** to **Off**
 - Set **BW** to **Full**
 - Set the volts/div scale to 100 mV
 - Position the channel 2 display approximately 0.5 divisions below the channel 1 display
12. Press the **CH 3** button.
13. Press the **VERTICAL MENU** button and make the following selections from the menu:
 - Set **CPLG** to **DC**
 - Set **VAR** to **Off**
 - Set **INV** to **Off**
 - Set **BW** to **Full**
 - Set the volts/div scale to 100 mV
 - Position the channel 3 display approximately 0.5 divisions below the channel 2 display
14. Press the **CH 4** button.
15. Press the **VERTICAL MENU** button and make the following selections from the menu:
 - Set **CPLG** to **DC**
 - Set **VAR** to **Off**
 - Set **INV** to **Off**
 - Set **BW** to **Full**
 - Set the volts/div scale to 100 mV
 - Position the channel 4 display approximately 0.5 divisions below the channel 3 display

Adjustment Procedures

16. Press the **CH 1** button.
17. Adjust Ch 1 10X on the Analog board for the flattest response of the most positive portion of the channel 1 waveform.
18. Set the channel 1 volts/div scale to 1 V.
19. Press the **CH 2** button.
20. Adjust Ch 2 10X adjustment on the Analog board for the flattest response of the most positive portion of the channel 2 waveform.
21. Set the channel 2 volts/div scale to 1 V.
22. Press the **CH 3** button.
23. Adjust Ch 3 10X adjustment on the Analog board for the flattest response of the most positive portion of the channel 2 waveform.
24. Set the channel 3 volts/div scale to 1 V.
25. Press the **CH 4** button.
26. Adjust Ch 4 10X adjustment on the Analog board for the flattest response of the most positive portion of the channel 2 waveform.
27. Set the channel 4 volts/div scale to 1 V.
28. Set the pulse generator amplitude to maximum.
29. Adjust Ch 4 100X on the Analog board for the flattest response of the channel 4 waveform.
30. Adjust Ch 3 100X on the Analog board for the flattest response of the channel 3 waveform.
31. Adjust Ch 2 100X on the Analog board for the flattest response of the channel 2 waveform.
32. Adjust Ch 1 100X on the Analog board for the flattest response of the channel 1 waveform.
33. Disconnect the test setup from the oscilloscope.

Vertical Gain Adjust (Cabinet On)

Equipment Required: None.

Adjustment Locations: This procedure requires adjustments to the Display Driver board. See Figures 5-14 and 5-15 on pages 5-18 and 5-19 for the location of the adjustments.

Prerequisites: Low Frequency Output Compensation, Factory Vertical Cal, and Attenuator Compensation adjustment procedures.

1. Slide the cabinet on the instrument and allow a 20-minute warm-up.
2. Press the **CURSOR** button and set Δ VOLT to **On**.
3. Set the volts/div scale to 1 V.

4. Position the cursors 6 divisions apart, centered vertically and check that the Δ Volts readout is between 5.96 V and 6.04 V.

NOTE

If the readout in step 4 is within the limits given, stop here. The calibration is complete.

If the readout is outside the limits, continue with this procedure.

5. Adjust the cursors until the Δ Volts readout is 6 V.
6. Note the cursor display error (are the cursors more or less than six divisions apart).
7. Slide the cabinet off the instrument and adjust R112 on the Display Driver board to compensate for the display error noted in step 6.

For example, if you noted in step 6 that the with the Δ Volts readout at 6 V, the cursor display equaled 6.2 divisions. Compensate by adjusting the cursor display to 5.8 divisions with R112.
8. Slide the cabinet on the instrument and repeat this procedure until the cursor display matches the Δ Volts readout.

Adjustment Complete

The adjustment procedure is complete. Install the cabinet and rear cover.

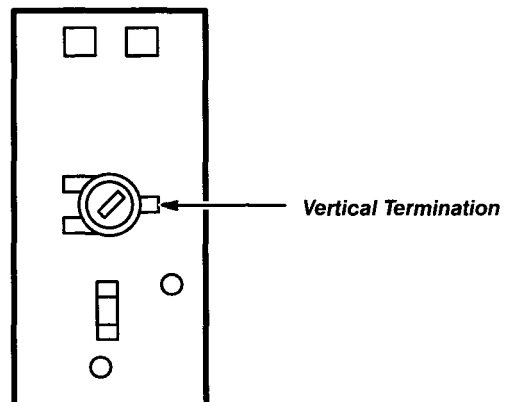

Figure 5-13: TAS 485 Vertical Termination Hybrid Adjustment

Adjustment Procedures

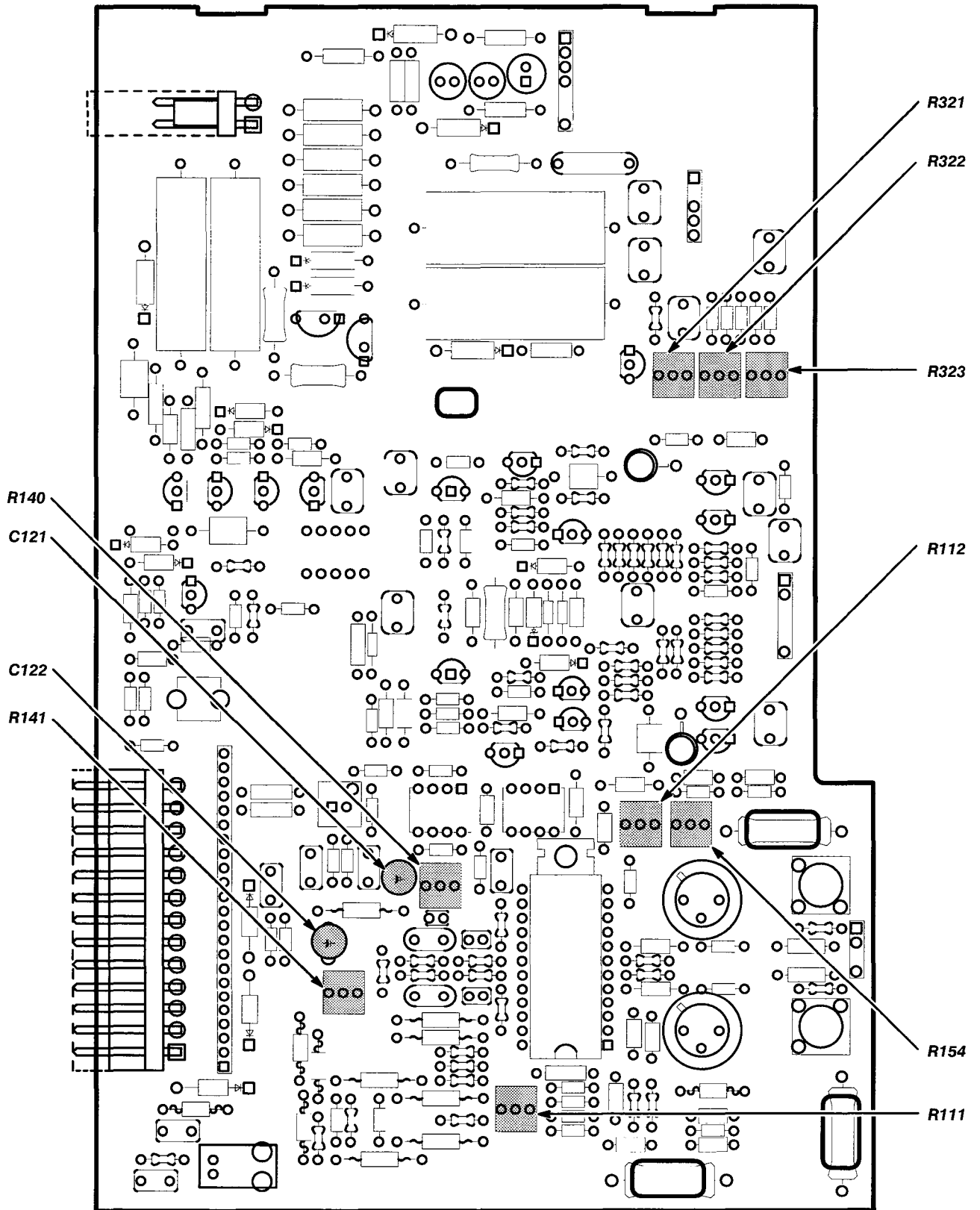

Figure 5-14: TAS 475 Display Driver Board Adjustment Locations

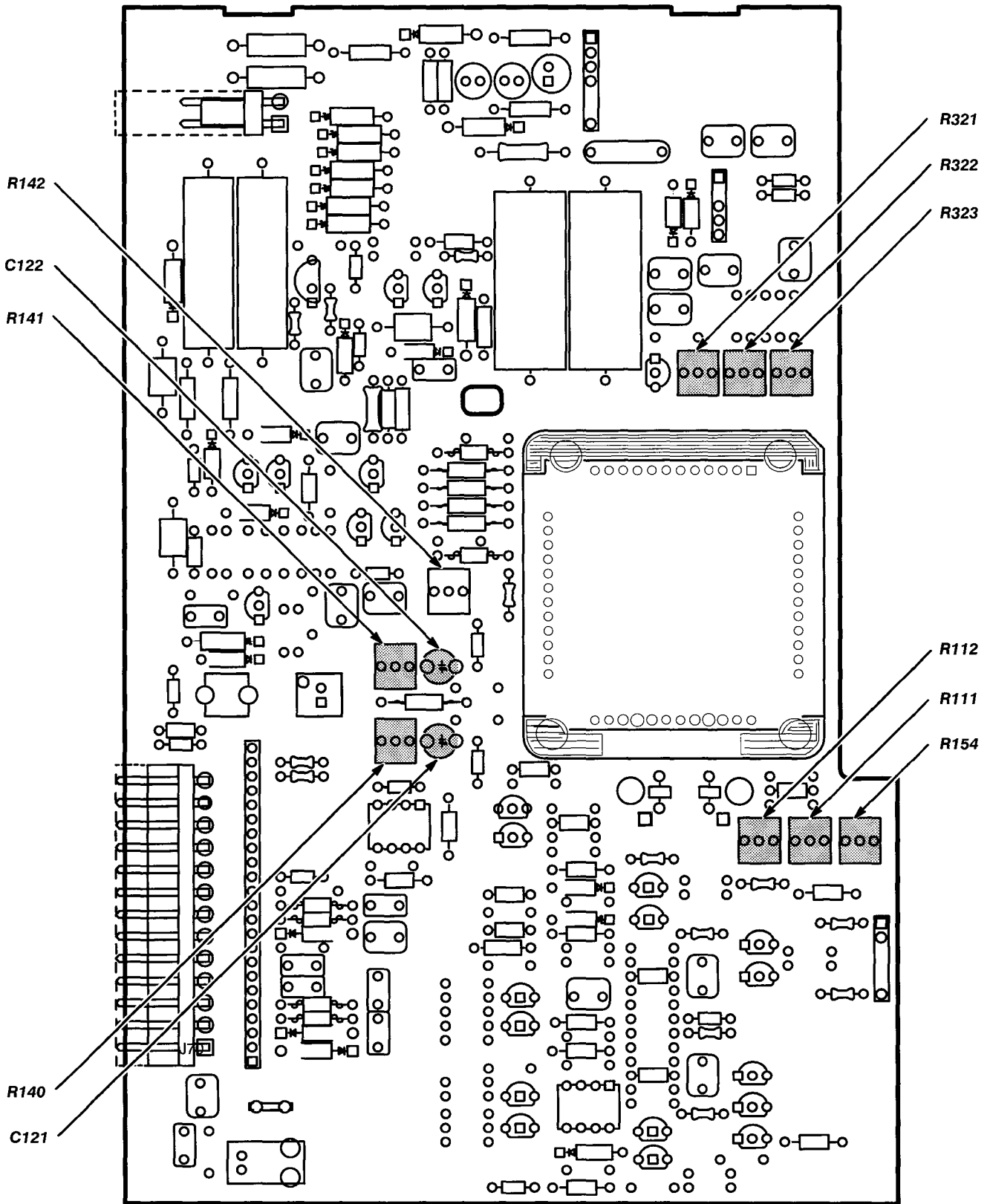

Figure 5-15: TAS 485 Display Driver Board Adjustment Locations

Adjustment Procedures

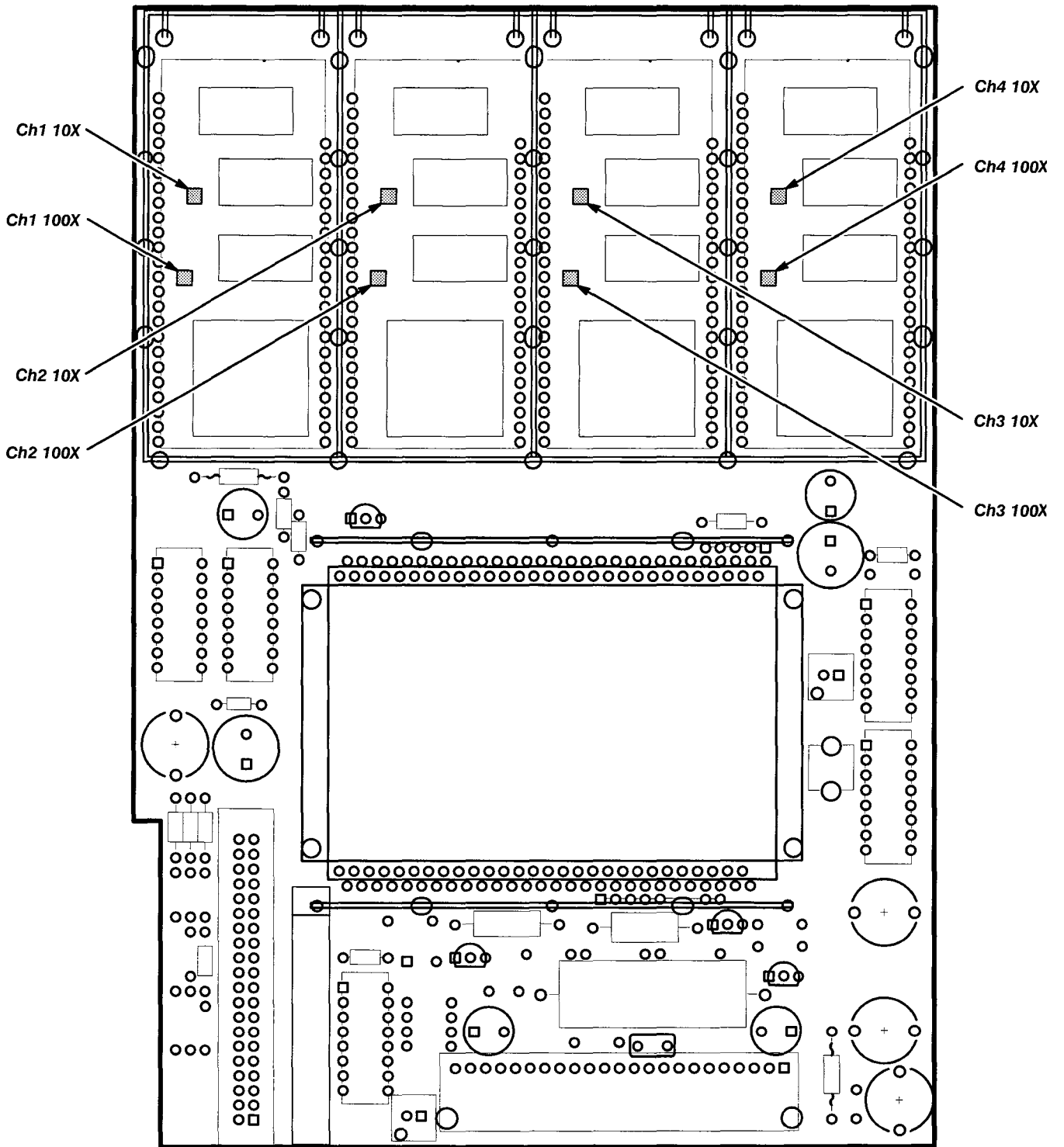

Figure 5-16: Analog Board Adjustment Locations

Maintenance Information

This section contains the information needed to do periodic maintenance on the TAS 475 and TAS 485 Analog Oscilloscopes.

- **Maintenance Information** — This subsection. It includes this introduction, servicing information, plus general information on preventing damage to internal modules when doing maintenance.
- **Inspection and Cleaning** — Information and procedures for inspecting the oscilloscope and cleaning its external and internal modules.
- **Removal and Installation Procedures** — Procedures for removing and installing the modules, circuit boards, and mechanical parts.
- **Troubleshooting Aids** — Procedures that help isolate problems to a module.

Before Servicing

This manual is for servicing of the TAS 475 and TAS 485 Analog Oscilloscopes. To prevent injury to yourself or damage to the oscilloscope, do the following before you attempt service.

- Be sure you are a qualified service person.
- Read the *Safety Summary* found at the beginning of this manual.

When using this manual for servicing, be sure to heed all warnings, cautions, and notes.

Tektronix Service

Tektronix provides service to cover repair under warranty as well as other services that may provide a cost-effective answer to your service needs.

Whether providing warranty repair service or any of the other services listed below, Tektronix service technicians, trained on Tektronix products, are best equipped to service your TAS 475 and TAS 485 Analog Oscilloscopes. Tektronix technicians are apprised of the latest information on improvements to the product as well as the latest new options.

Warranty Service

Tektronix warrants this product for three years from date of purchase, excluding probes for which the warranty is one year. (The warranty appears on the back of the title page in this manual.) Tektronix technicians provide warranty service at most Tektronix service locations worldwide. Your Tektronix product catalog lists all service locations worldwide.

Repair or Calibration Service

Tektronix offers several types of service contracts that you may purchase to tailor repair and/or calibration of your TAS 475 and TAS 485 Analog Oscilloscopes to fit your requirements.

Refer to the *Warranty-Plus Service Options*, Page 7-1, for a list of the available service contracts for the TAS 475 and TAS 485 Analog Oscilloscopes.

Self Service

This manual contains all the information needed for periodic maintenance and repair of the TAS 475 and TAS 485 Analog Oscilloscopes.

For periodic maintenance, use these sections:

- Performance verification procedures
- Calibration procedures

For instrument repair, use these sections:

- Troubleshooting aids to help isolate problems to a module
- Disassembly procedures
- Electrical schematics
- Parts lists

Replace failed modules with fully tested modules obtained from the factory. Schematics of each module are provided for repair to the component level of the circuit boards where feasible.

For information, contact your local Tektronix service center or sales engineer on any repair services.

Preventing ESD

When performing any service which requires internal access to the oscilloscope, adhere to the following precautions to avoid damaging internal modules and their components due to electrostatic discharge (ESD).



Static discharge can damage any semiconductor component in this oscilloscope.

1. Minimize handling of static-sensitive modules.
2. Discharge the static voltage from your body by wearing a grounded antistatic wrist strap while handling these modules. All service must be done at a static-free work station.

3. Do not remove the oscilloscope cabinet unless you have met precaution number 2, above. Consider all internal modules static-sensitive.
4. Remove anything capable of generating or holding a static charge from the work station surface.
5. Do not slide the modules over any surface.
6. Do not use high-velocity compressed air when cleaning dust from modules.

Susceptibility to ESD

Table 6-1 lists the relative susceptibility of various classes of semiconductors. Static voltages of 1 kV to 30 kV are common in unprotected environments.

Table 6-1: Relative Susceptibility to Static-Discharge Damage

Semiconductor Classes	Relative Susceptibility Levels ¹
MOS or CMOS microcircuits or discrete circuits, or linear microcircuits with MOS inputs (most sensitive)	1
ECL	2
Schottky signal diodes	3
Schottky TTL	4
High-frequency bipolar transistors	5
JFET	6
Linear microcircuits	7
Low-power Schottky TTL	8
TTL (least sensitive)	9

¹Voltage equivalent for levels (voltage discharged from a 100 pF capacitor through resistance of 100 ohms):

1 = 100 to 500 V	6 = 600 to 800 V
2 = 200 to 500 V	7 = 400 to 1000 V (est.)
3 = 250 V	8 = 900 V
4 = 500 V	9 = 1200 V
5 = 400 to 600 V	

Inspection and Cleaning

Inspection and Cleaning describes how to inspect and clean the TAS 475 and TAS 485 Analog Oscilloscopes. Inspection and cleaning are preventive maintenance. Preventive maintenance, when done regularly, may prevent oscilloscope malfunction and enhance its reliability.

Preventive maintenance consists of visually inspecting and cleaning the oscilloscope and using general care when operating it.

How often to do maintenance depends on the severity of the environment in which you use the oscilloscope. A proper time to perform preventive maintenance is just before oscilloscope adjustment.

General Care

The cabinet helps keep dust out of the oscilloscope and it is a major component of its cooling system. It should normally be in place when operating the oscilloscope. The oscilloscope's front cover protects the front panel and display from dust and damage. Install it when storing or transporting the oscilloscope.

Inspection and Cleaning Procedures

Inspect and clean the oscilloscope as often as operating conditions require. The collection of dirt on components inside can cause them to overheat and breakdown. (Dirt acts as an insulating blanket, preventing efficient heat dissipation.) Dirt also provides an electrical conduction path that could cause an oscilloscope failure, especially under high-humidity conditions.



CAUTION

Avoid the use of chemical cleaning agents that might damage the plastics used in this oscilloscope. Use a 75% isopropyl alcohol solution as a cleaner and rinse with deionized water. Use only deionized water when cleaning the menu buttons or front-panel buttons. Before using any other type of cleaner, consult your Tektronix Service Center or representative.

Avoid the use of high pressure compressed air when cleaning dust from the interior of this instrument. (High pressure air can cause ESD.) Instead, use low pressure compressed air (about 9 psi).

Inspection — Exterior

Inspect the outside of the oscilloscope for damage, wear, and missing parts. Use Table 6-2 as a guide. Oscilloscopes that appear to have been dropped or otherwise abused should be checked thoroughly to verify correct operation and performance. Repair defects that could cause personal injury or lead to further damage to the oscilloscope immediately.

Table 6-2: External Inspection Check List

Item	Inspect For	Repair Action
Cabinet, front panel, and cover	Cracks, scratches, deformations, damaged hardware or gaskets.	Replace defective module.
Front-panel knobs	Missing, damaged, or loose knobs.	Repair or replace missing or defective knobs.
Connectors	Broken shells, cracked insulation, and deformed contacts. Dirt in connectors.	Replace defective modules. Clear or wash out dirt.
Carrying handle and cabinet feet	Correct operation.	Repair or replace defective module.
Accessories	Missing items or parts of items, bent pins, broken or frayed cables, and damaged connectors.	Replace damaged or missing items.

Cleaning Procedure — Exterior

1. Remove loose dust on the outside of the oscilloscope with a lint free cloth.
2. Remove remaining dirt with a lint free cloth dampened in a general purpose detergent-and-water solution. Do not use abrasive cleaners.



To prevent getting moisture inside the oscilloscope during external cleaning, use only enough liquid to dampen the cloth or applicator.

3. Clean the CRT screen with a lint-free cloth dampened with either a 75% isopropyl alcohol solution or, preferably, a gentle, general purpose detergent-and-water solution.

NOTE

If the CRT Implosion Shield needs further cleansing, refer to the procedure on page 6-7.

Cleaning Procedure — Interior



If, after doing steps 1 and 2, a module is clean upon inspection, skip the remaining steps.

1. Blow off dust with dry, low-pressure, deionized air (approximately 9 psi).
2. Remove any remaining dust with a lint free cloth dampened in isopropyl alcohol (75% solution) and rinse with a warm deionized water. (A cotton-tipped applicator is useful for cleaning in narrow spaces and on circuit boards.)
3. If steps 1 and 2 do not remove all the dust or dirt, the oscilloscope may be spray washed using a solution of 75% isopropyl alcohol by doing steps 4 through 8.
4. Gain access to the parts to be cleaned by removing easily accessible shields and panels (see "Removal and Installation Procedures").
5. Spray wash dirty parts with the isopropyl alcohol solution and wait 60 seconds for the majority of the alcohol to evaporate.
6. Use hot (+50° C to +60° C) deionized water to thoroughly rinse them.
7. Dry all parts with low-pressure, deionized air.
8. Dry all components and assemblies in an oven or drying compartment using low-temperature (+50° C to +60° C) circulating air.

Cleaning the CRT Implosion Shield



This procedure describes how to clean both sides of the CRT Implosion Shield, thus requiring its removal. Perform this procedure only if cleaning the backside of the Implosion Shield is necessary.

1. Remove the Implosion Shield as described in the Removal and Replacement procedures beginning on page 6-27.
2. Clean the shield with a lint free cloth dampened in a general purpose detergent-and-water solution. Do not use abrasive cleaners.
3. Remove any static charge that may have accumulated by holding the shield in a deionized air flow.
4. Install the shield as described in the Removal and Replacement procedures beginning on page 6-27.

Removal and Installation Procedures

This subsection contains procedures for removal and installation of all replaceable mechanical and electrical modules. Replaceable mechanical and electrical modules are listed in Sections 8 and 10 of this manual.

Preparation — Please Read

WARNING

Before doing this or any other procedure in this manual, read the Safety Summary found at the beginning of this manual. Also, to prevent possible injury to service personnel or damage to oscilloscope components, read Before Servicing and Supplying Operating Power in Section 2, and Preventing ESD in this section.

This subsection contains the following:

- This preparatory information that you need to properly do the procedures that follow.
- A list of equipment required to remove and disassemble all modules.
- Procedures for removal and reinstallation of the electrical and mechanical modules.
- Three module locator diagrams for finding all the modules in this oscilloscope. (See Figures 6-2, 6-3, and 6-4.)

WARNING

Before doing any procedure in this subsection, disconnect the power cord from the line voltage source. Failure to do so could cause serious injury or death.

Cable Removal

Cables are partially or completely removed in the course of removing a board or module they plug into.

General Instructions



READ THESE GENERAL INSTRUCTIONS BEFORE REMOVING A MODULE.

First read over the *Summary of Procedures* that follows to understand how the procedures are grouped. Then read *Equipment Required* for a list of the tools needed to remove and install modules in this oscilloscope.

Procedures refer to the "front," "rear," "top," etc. of the oscilloscope. Figure 6-1 illustrates these references.

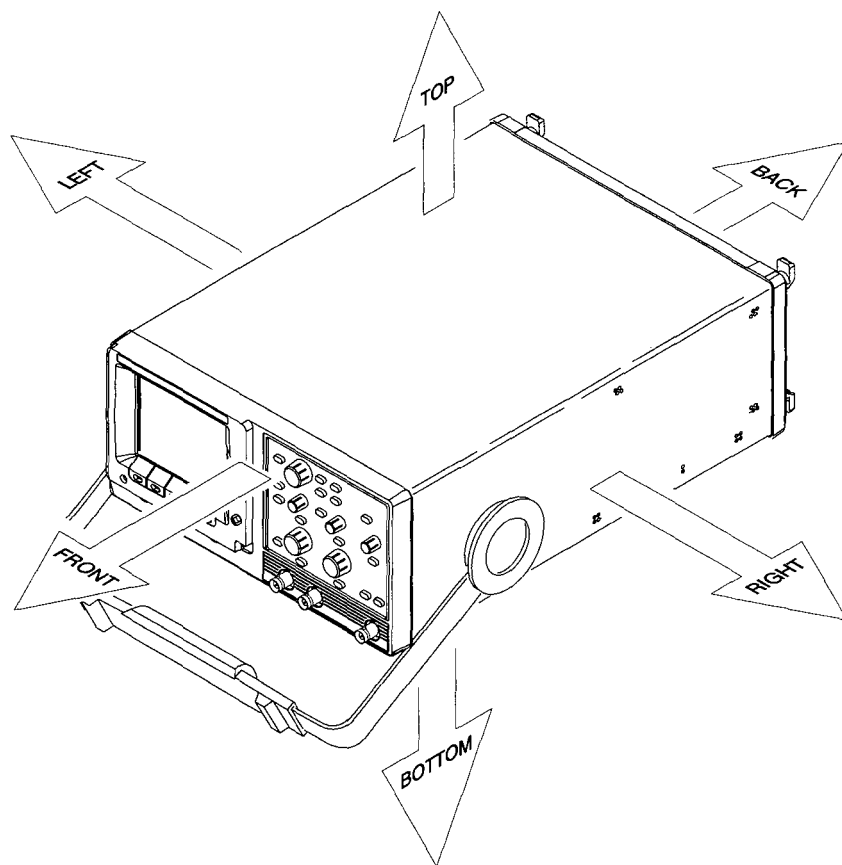

Figure 6-1: Oscilloscope Orientation

Summary of Procedures

The procedures are described in the order in which they appear in this section. In addition, you can look up any procedure for removal and reinstallation of any module in the *Table of Contents* of this manual.

Equipment Required — Table 6-3 lists the tools required to completely disassemble the oscilloscope into its modules.

All the tools are standard tools readily available from tool suppliers.

Table 6-3: Tools Required for Module Removal

Item No.	Name	Description
1	Screwdriver handle	Accepts Torx®-driver bits.
2	T-15 Torx tip	Torx®-driver bit for T-15 size screw heads.
3	T-20 Torx tip	Torx®-driver bit for T-20 size screw heads. Used only for removal of the cabinet handle.
4	Nut driver, 5/16 inch	Used for removing the CRT earth ground cable.
5	Angle-tip tweezers	Used for knob and shaft removal.
6	Flat-bladed spudger	A non-metallic probe-like tool with a flat bladed tip. Used to remove the front-panel trim and front module.
7	Slip-Jaw Pliers	Used for removing the front feet from the cabinet.

Removal and Installation Procedures

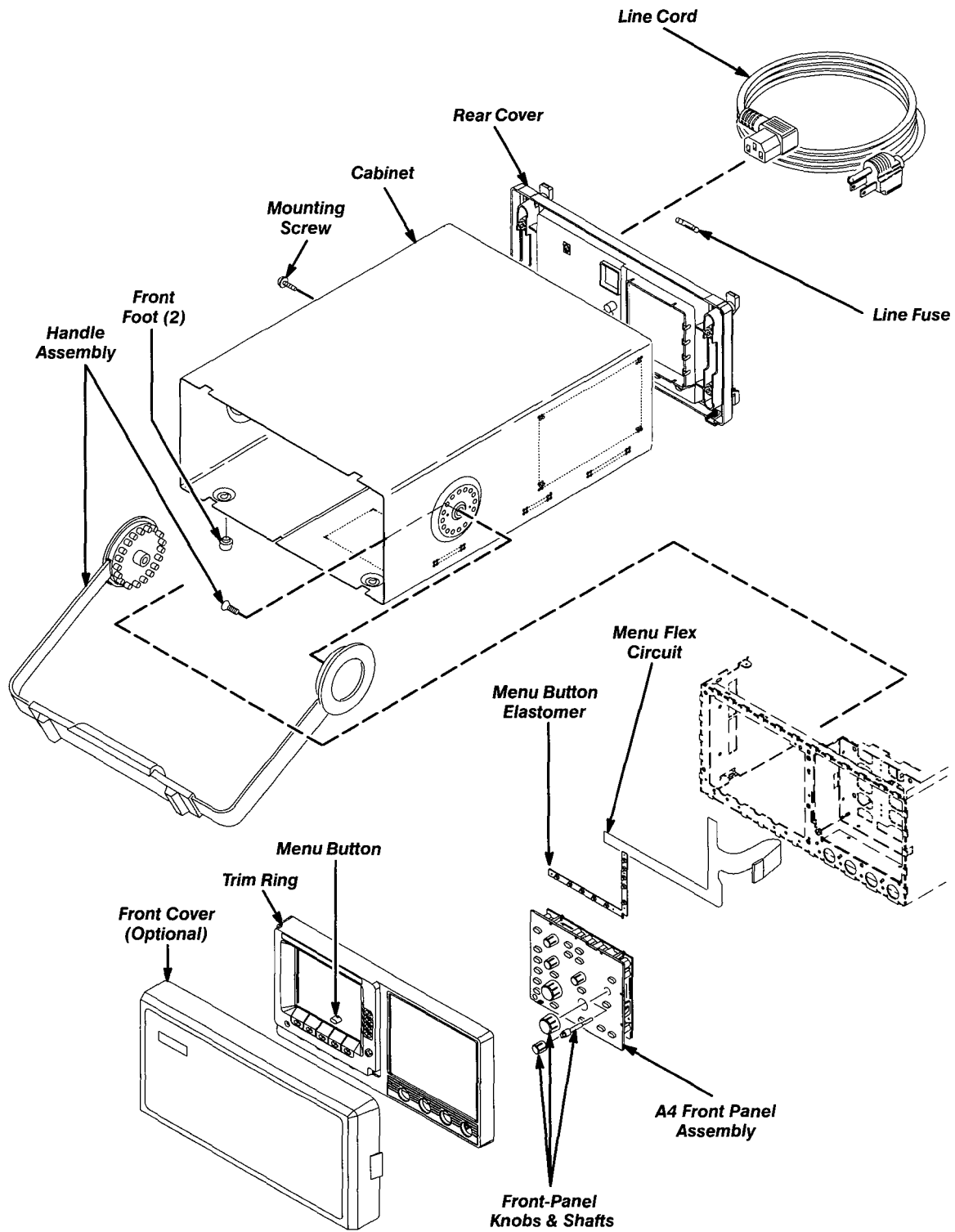

Figure 6-2: Cabinet and Front-Panel Mounted Modules

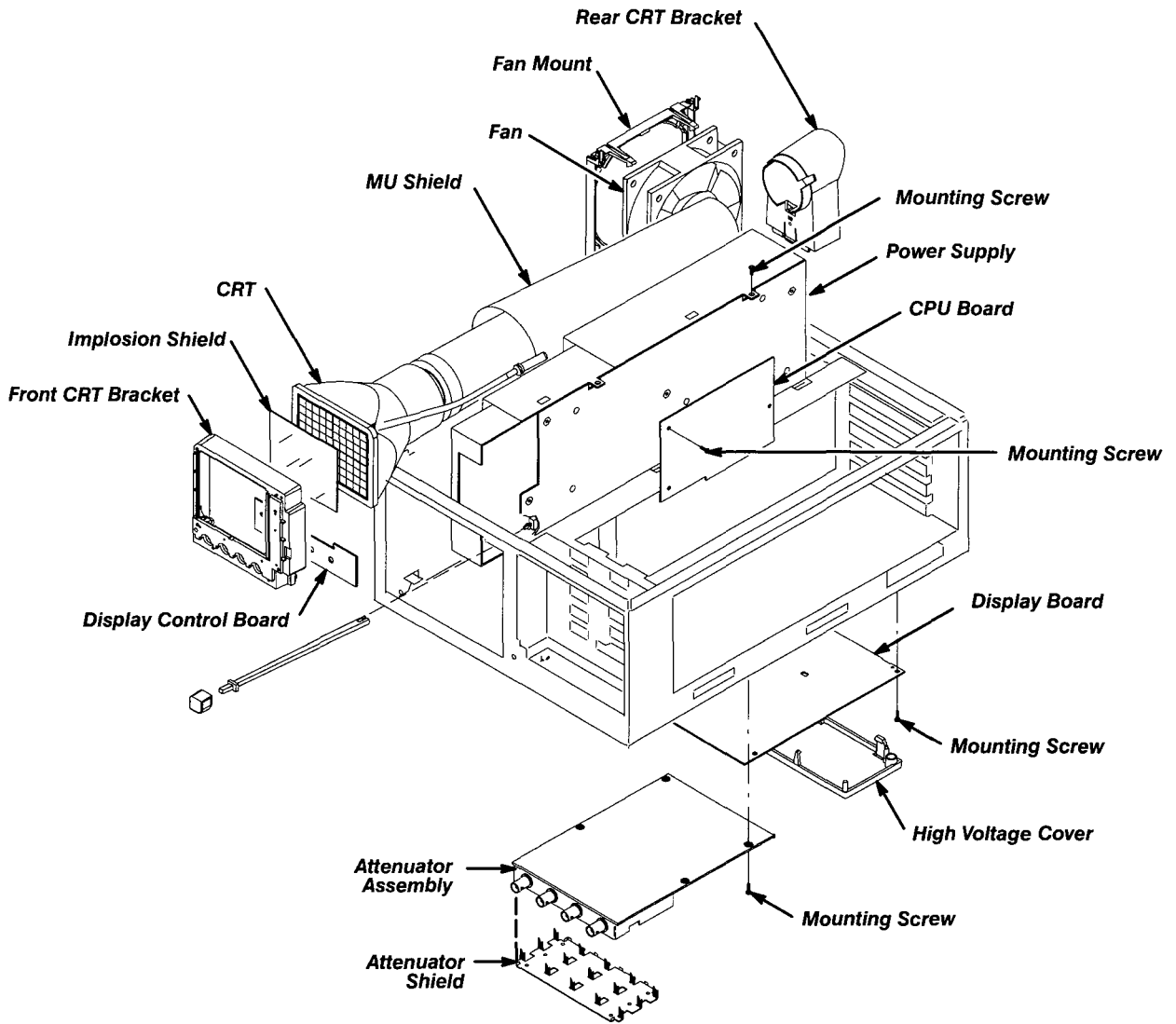

Figure 6-3: Internal Modules

Removal and Installation Procedures

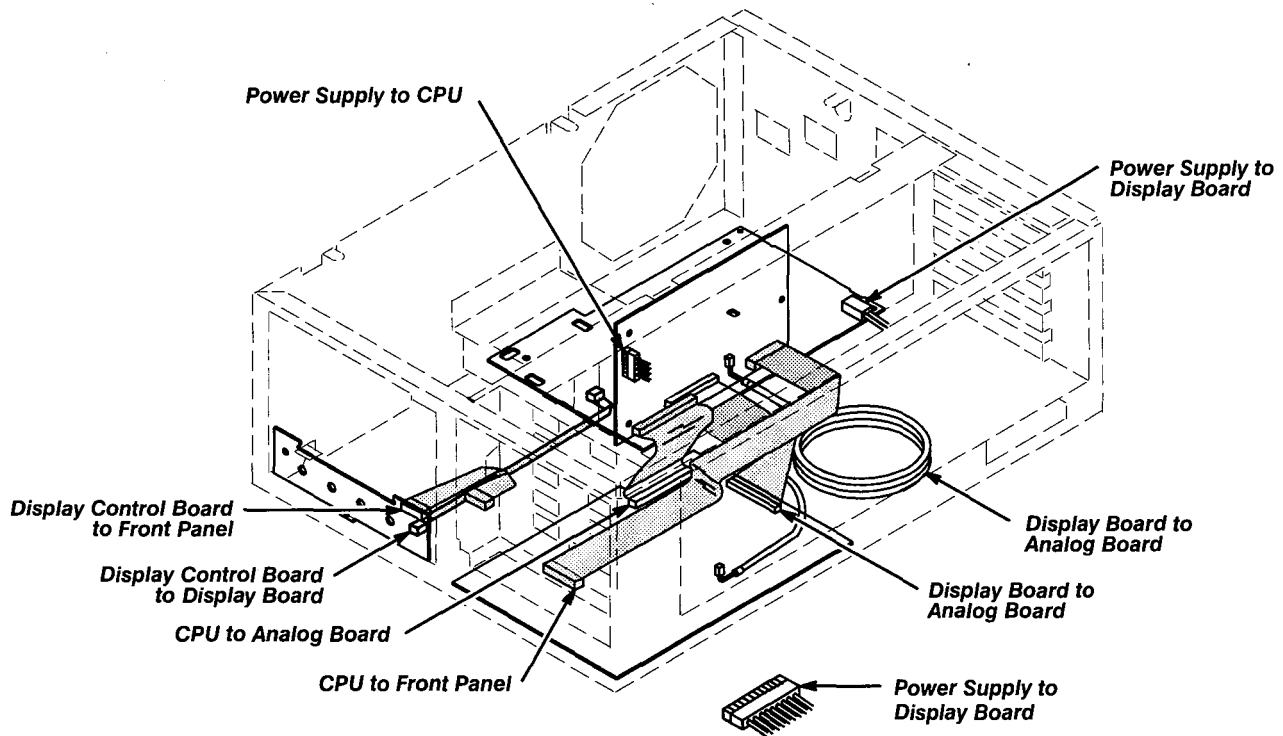

Figure 6-4: Cables and Cable Routing

Line Cord and Line Fuse

The following procedures describe how to remove and install the line cord and line fuse located on the back side of the oscilloscope.

WARNING

Unplug the line cord from the line voltage power source before continuing. Failure to do so can cause injury or death.

Prepare the oscilloscope by positioning the bottom side down on the work surface and facing the back side toward you. Refer to Figure 6-5.

Line Cord

1. Unplug the line cord from the power source.
2. Unplug the other end of the line cord from the back of the oscilloscope.
3. Grasp the end of the line cord and retaining clamp and rotate them 90 degrees counterclockwise (Figure 6-5).
4. Pull the line cord and clamp away from the back of the oscilloscope.

5. Perform this procedure in reverse order to install the power cord on the oscilloscope.

Line Fuse

1. Unplug the line cord from the power source.
2. Pull out the fuse holder drawer and remove the fuse (Figure 6-5).
3. Perform this procedure in reverse order to install the fuse.

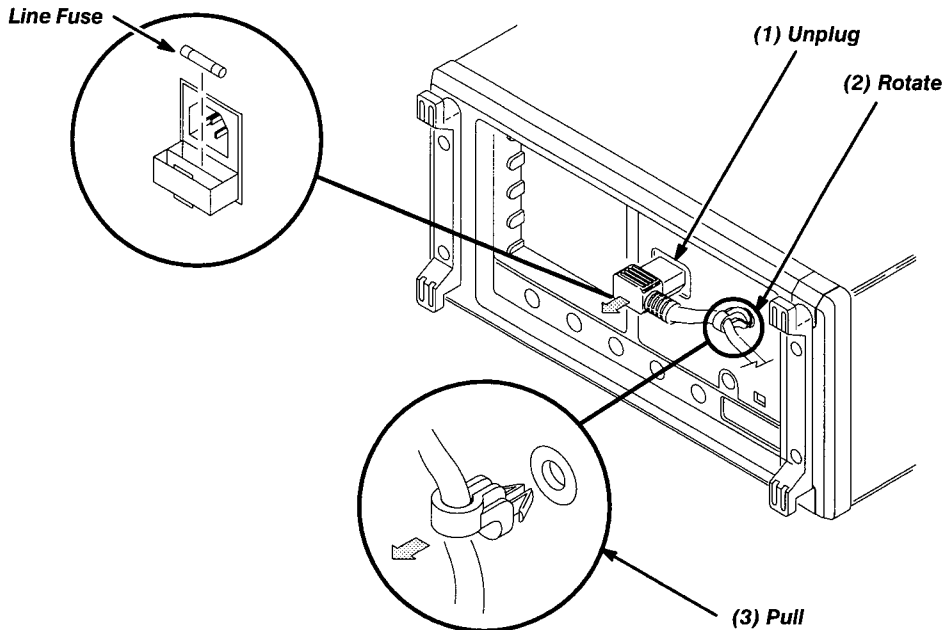

Figure 6-5: Line Fuse and Line Cord Removal

Front-Panel Knobs and Shafts

Use the following procedures to remove and install front-panel knobs and shafts.

Prepare the oscilloscope by setting it bottom side down on the work surface and facing the front side toward you.

Removing Front-Panel Knobs and Shafts

1. Remove any knob by pulling it straight out from the front panel slightly. This will create some clearance between the base of the knob and the front panel to create some clearance between the base of the knob and the front panel.
2. Insert the tweezers between the knob and front panel and use them to remove the knob and attaching shaft (see Figure 6-6).

Removal and Installation Procedures

3. Pull the shaft out of the knob to separate the two pieces.

Installing Front-Panel Knobs and Shafts

1. Align the inside of the knob to the end of the shaft and push it in until it snaps.
2. Insert the shaft of the assembly into the proper hole on the front panel and push it in until it stops.
3. Lightly push in the knob and rotate it until the shaft slips into place.
4. Push the knob all the way in to seat the assembly.

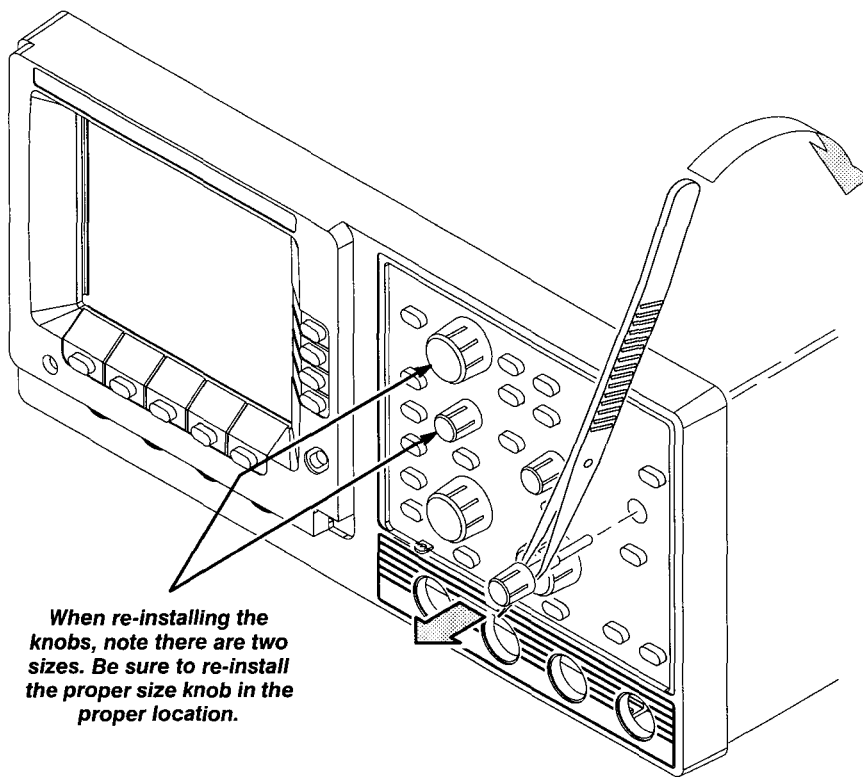

Figure 6-6: Knob and Shaft Removal

Feet, Rear Cover, and Cabinet

Before removing the rear cover or cabinet, install the optional front cover on the front panel of the oscilloscope (if available) and then position the oscilloscope as indicated in Figure 6-7.

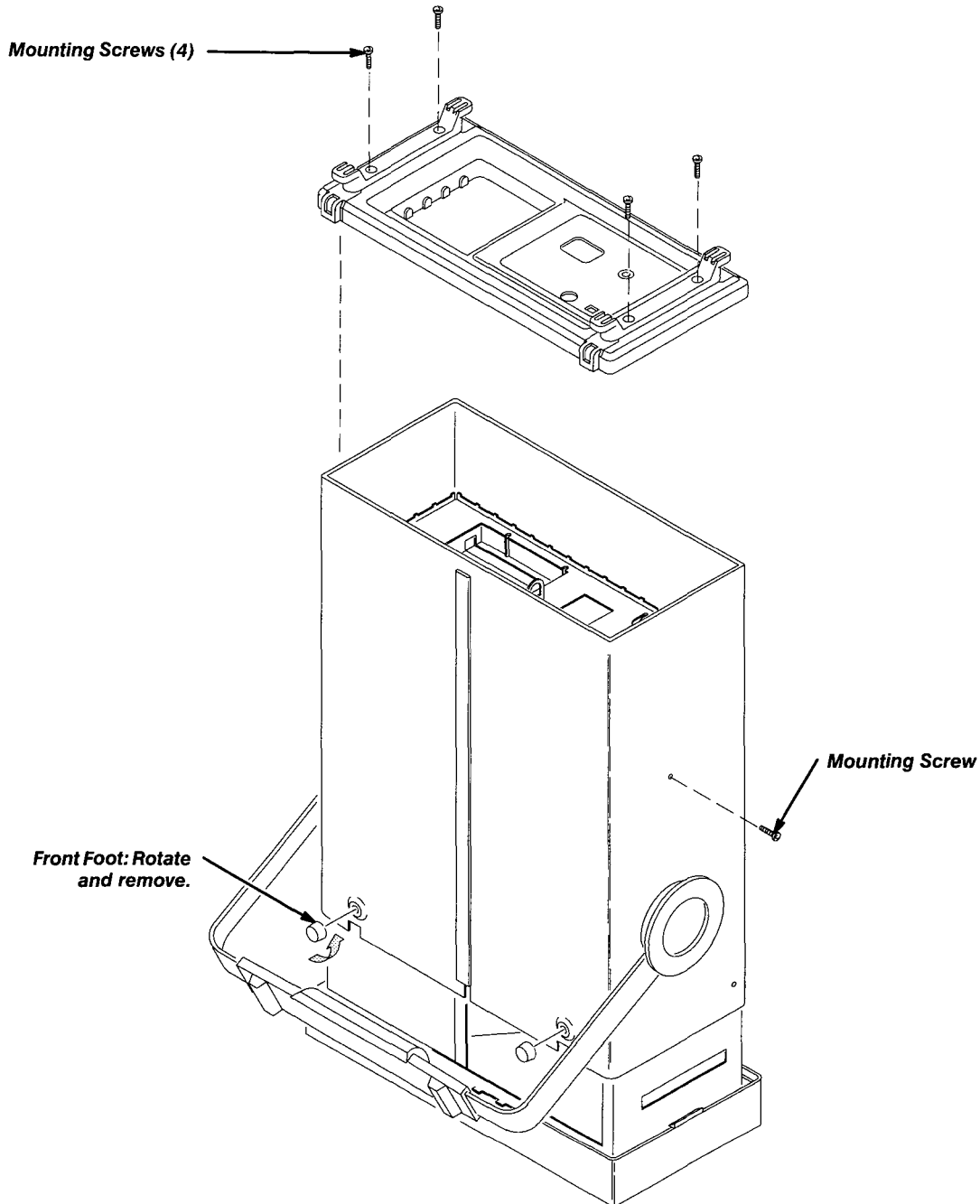

Figure 6-7: Rear Cover, Cabinet, and Feet Removal

Rear Cover

1. Position the oscilloscope as indicated in Figure 6-7.
2. Use the screwdriver to remove the four T-15 Torx screws that secure the rear cover to the oscilloscope.
3. Lift off the rear cover. Do these steps in reverse order to install the rear cover.

Cabinet

1. Remove the rear cover.
2. Remove the single T-15 Torx screw on the left side of the oscilloscope.
3. Grasp the two handle hubs and pull them outward as if to rotate the handle.
4. While holding the handle hubs out, lift the cabinet up and slide it off the oscilloscope. Take care not to bind or snag the cabinet on the internal cabling as you remove it.

Replacing the Front Feet

If you are replacing a front foot, use a pair of slip-jaw pliers to firmly grip the foot, then pull with a turning motion to remove. Do this step in reverse order to replace the foot.

Front-Panel Trim, Menu and Power Buttons, EMI Gasket

Use the following procedures to remove and install front-panel trim, buttons, and EMI gaskets.

Additional procedures required — These procedures require that the following procedures be performed first:

- Rear Cover Removal
- Cabinet Removal

Removing the Front Trim

1. Slide a flat-bladed spudger between the chassis and the plastic front trim, near one of the four flex locks. See Figure 6-8.
2. Gently pry the front trim up and slightly forward to disengage the flex lock. Do this until all four flex locks are disengaged.
3. Pull the front trim forward and off the instrument.

Menu Buttons and Elastomer

1. Lay the front trim on a flat surface.
2. Gently remove menu button elastomer. Avoid touching the electrical contacts.
3. Remove the menu button(s).
4. Install menu buttons by placing a menu button in each menu button location.
5. Place the menu button elastomer over the menu buttons, ensuring that all standoffs protrude through the elastomer. Avoid touching the electrical contacts.

Power Button Replacement

1. With the front trim removed, grasp the power button and pull straight out from the chassis.
2. Install the power button by pushing the button onto the power button shaft until it locks into place.

Installing the Front Trim

1. If the menu buttons were removed, insert each button to its hole in the trim ring and install the menu button elastomer.
2. Align the front trim to the front of the instrument, without engaging any of the four flex locks.
3. Position the power button in line with the front-panel power button opening.
4. Slide the front trim onto the instrument, ensuring that all four flex locks engage.
5. If installing a new front trim, apply the appropriate front trim label.

Removal and Installation Procedures

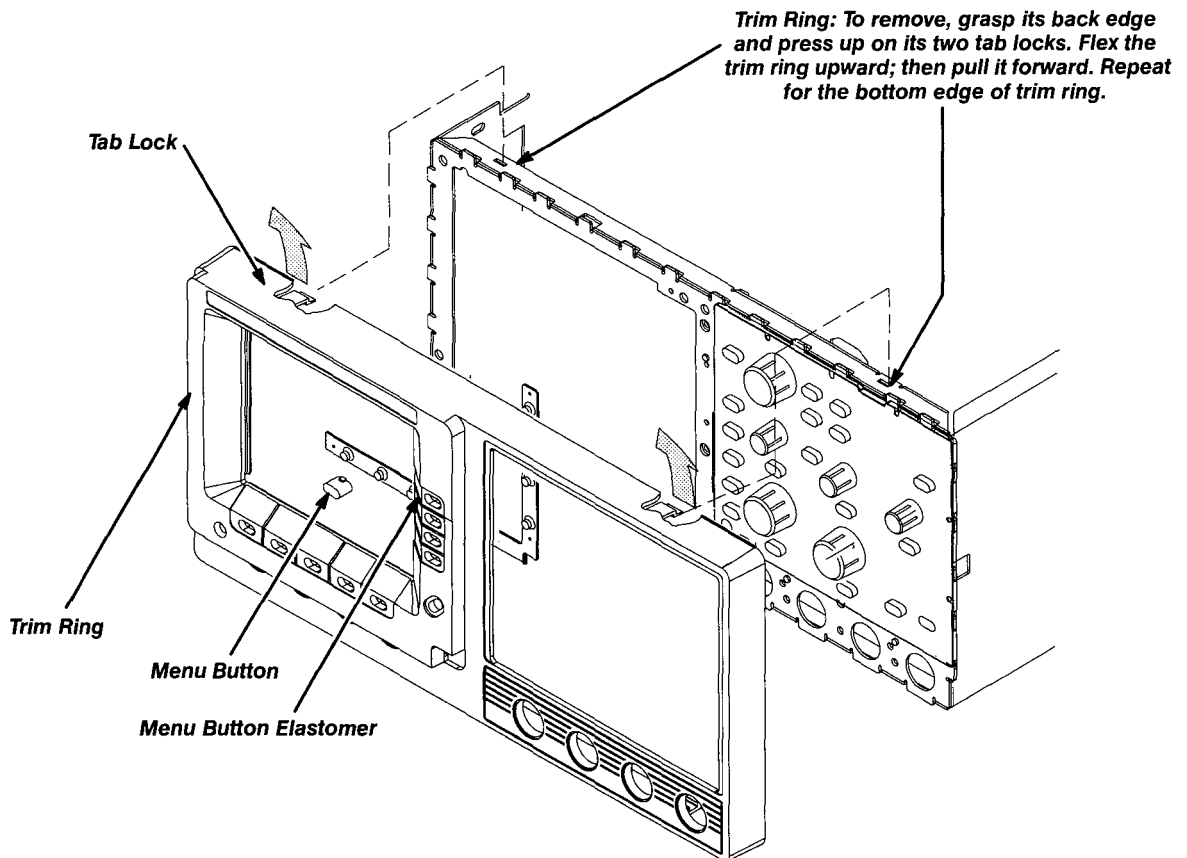

Figure 6-8: Trim Ring and Menu Buttons Removal

Installing the EMI Gaskets (TAS 485 Only)

The EMI gaskets are only used on TAS 485 oscilloscopes with serial numbers B010321 and above. Oscilloscopes with earlier serial numbers do not contain the gaskets.

1. If you are servicing the front EMI gaskets, discard the old ones.
2. Without installing the EMI gaskets, align the trim ring to the front of the chassis and push it on to seat. Be sure that both pairs of flex locks, one pair each at the inside top and bottom of the trim ring, snap over the edge of the chassis.
3. Lay the oscilloscope so its front cover is on the work surface.
4. Align an EMI gasket so it lies between any pair of adjacent flex locks along the groove between the cabinet and the trim ring.
5. Using a flat-bladed spudger, push the EMI gasket until it is firmly seated at the bottom of the groove (see Figure 6-9). It should not overlap either flex lock.
6. Repeat the process just described to install the remaining three gaskets.

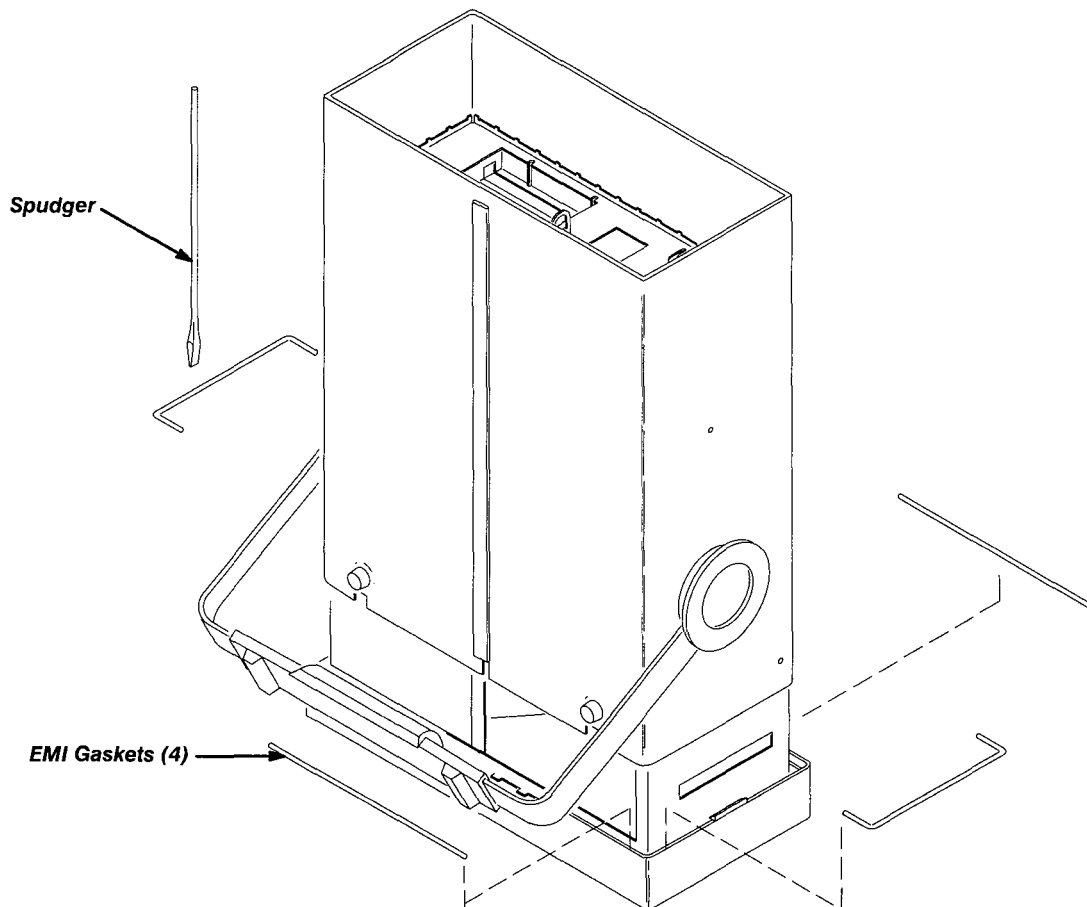

Figure 6-9: EMI Gasket Installation

A62 Front Panel Module Removal

The following procedure describes how to remove the A62 Front Panel module.

Additional procedures required — This procedure requires that the following procedures be performed first:

- Rear Cover Removal
 - Cabinet Removal
 - Front-Panel Trim Ring
1. Set the oscilloscope so its bottom is down on the work surface and its front is facing you.
 2. Insert a flat-bladed screwdriver into the slot at the front-right of the chassis. Push inwards to release the snap lock at the right side. (See Figure 6-10.)

Removal and Installation Procedures

3. Pull the Front Panel module slightly away from the front of the chassis until you can reach the interconnect cables at the rear of the module.
4. Unplug the following cables from their jacks on the Front Panel module:
 - The Display Control-to-front-panel cable at J84
 - The menu flex circuit-to-front panel at J40
 - The CPU-to-front-panel cable at J30
5. Lift the Front Panel module out from the chassis.

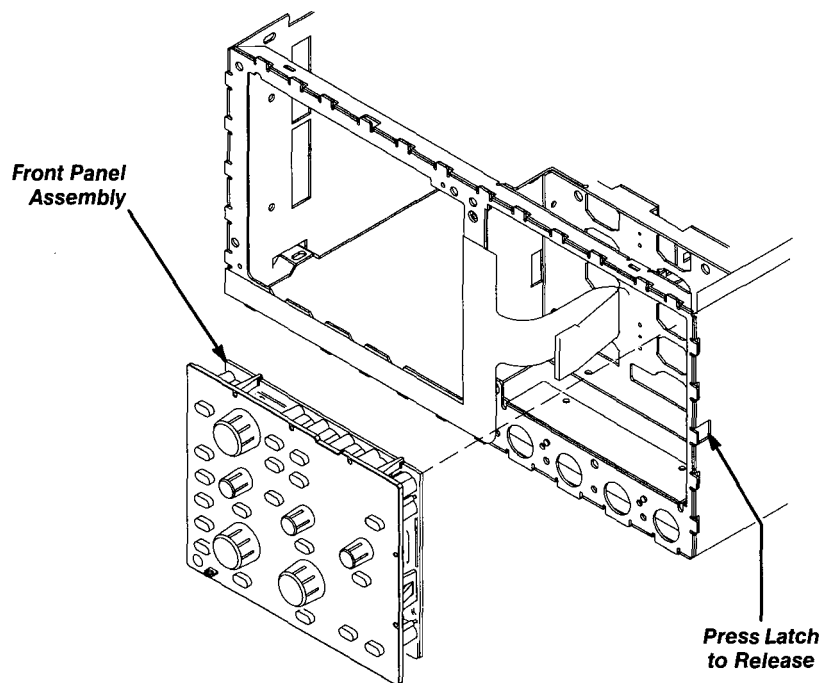

Figure 6-10: A62 Front Panel Module Removal

Front-Panel Module Disassembly/Assembly

The following procedures describe the disassembly of the Front Panel module into its subparts once it is removed from the instrument.

Additional procedures required — These procedures require that the following procedures be performed first:

- Front-Panel Knobs and Shafts Removal

A4 Front Panel board Removal — Perform the following steps to remove the Front Panel board.

1. Remove the front-panel knobs and shafts from the module.

2. Holding the Front Panel module, release the three snap locks at the edge of the circuit board, then tilt the board away from the assembly until it unplugs from J35. See Figure 6-11.
3. Slide the circuit board out from the retainers found at the edge opposite the snap locks and lift it away from the rest of the assembly.
4. At this point, the control potentiometers may be lifted out for cleaning (they are not field replaceable). Lift the two potentiometers out from the back of the front-panel assembly.

Front-Panel Buttons and Elastomer — Perform the following steps only if replacing a damaged button or the front-panel button elastomer.

5. Remove the front-panel button elastomer from the back of the front-panel assembly. Do not touch the contacts with your fingers. See Figure 6-11.
6. Replace damaged buttons or elastomer.

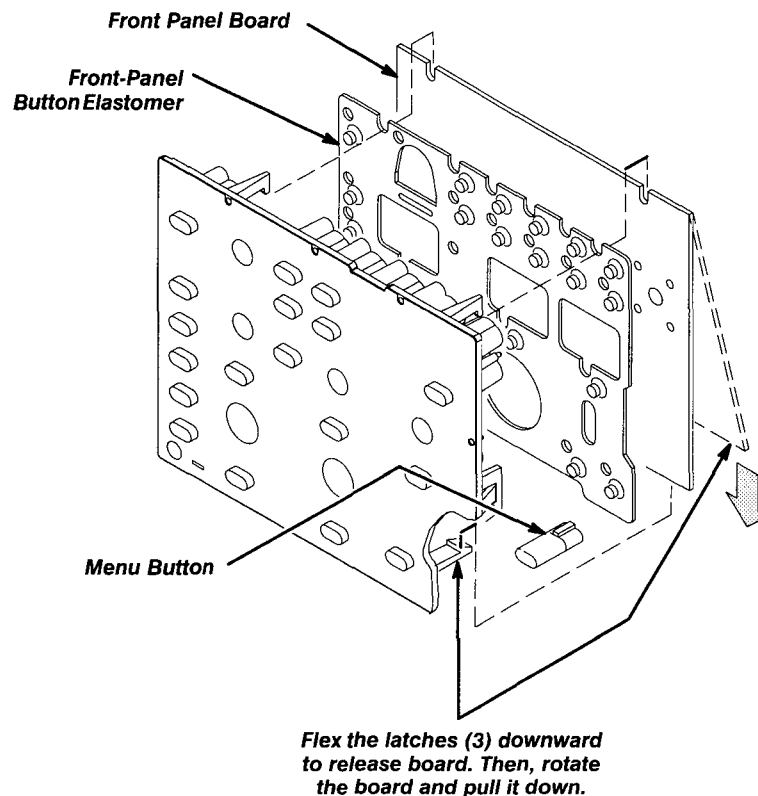

Figure 6-11: Disassembly of Front-Panel Assembly

Ground Spring Removal — Perform the next step only if replacing a damaged ground spring.

Removal and Installation Procedures

7. Using Figure 6-12 as a guide, grasp (compress) the base of the ground spring (to release the spring) with tweezers (Item 5) and pull the ground spring away from the assembly.

Reassembly of the Front Panel Module — Perform the next steps to reassemble the Front Panel module.

8. If the front-panel assembly was disassembled for cleaning in step 4, apply a light, thin coating of bearing grease (Dow Corning #1292) to the two switch patterns (circular patterns for the vertical and horizontal scale rotary switches) on the circuit board.
9. Perform in reverse order each step taken during the disassembly of the Front Panel module.

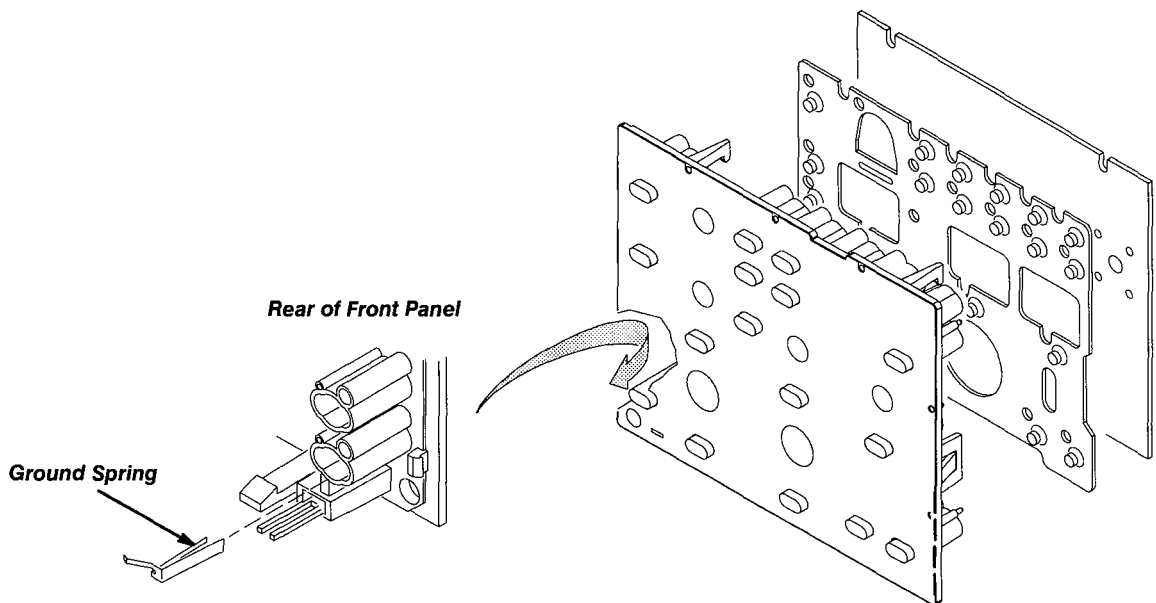

Figure 6-12: Front-Panel Ground Spring

Menu Flex Circuit Replacement



Perform this procedure only if replacing a failed or damaged menu flex circuit with a fresh unit from the factory. (Removal of the circuit is likely to destroy it.)

Additional procedures required — This procedure requires that the following procedures be performed first:

- Rear Cover Removal
- Cabinet Removal
- Front Trim Removal

■ A62 Front Panel Module Removal

1. Pull the flex circuit away from the front of the main chassis. (It is held on by its sticky backing.) See Figure 6-13.
2. Wipe the front of the chassis using isopropyl alcohol and a clean, lint-free cloth. Let dry. (Some adhesive from the flex circuit you removed will be left on the front of the chassis. This is normal.)

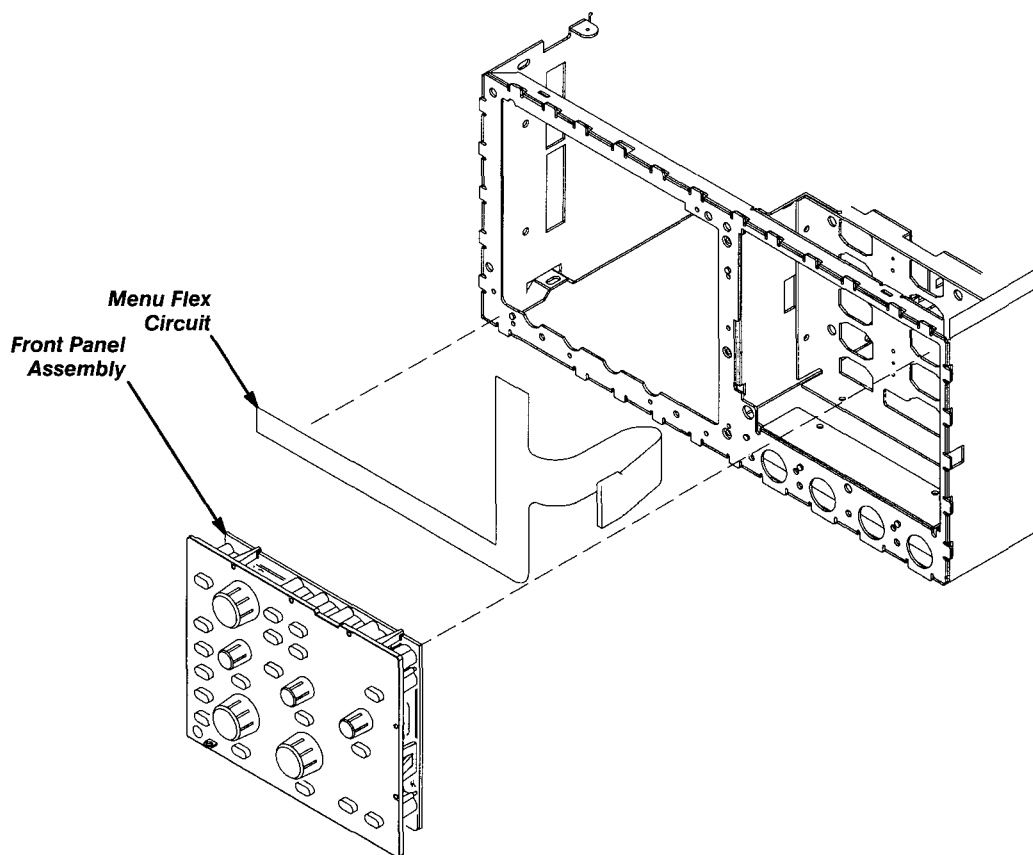

Figure 6-13: Menu Flex Circuit Board Removal

3. Find the score line in the adhesive backing and peel the backing off of the menu flex circuit.

NOTE

DO NOT touch the contacts on the menu flex circuit with your bare fingers. You should wear clean cloth gloves that are free of lint when installing the menu flex circuit on the front chassis.

Removal and Installation Procedures

4. Carefully align the three holes on the menu flex circuit to the locator studs on the front of the main chassis. When the alignment is correct, press the flex circuit against the chassis so it adheres to the chassis.
5. Clean the surface of the menu flex circuit just installed using isopropyl alcohol and a clean, lint-free cloth.
6. Repeat all procedures performed in reverse order to reassemble the instrument.

A1 Analog Board

The following procedure describes how to remove the A1 Analog board.

Additional procedures required — This procedure requires that the following procedures be performed first:

- Rear Cover Removal
 - Cabinet Removal
 - Front Trim Removal
1. Set the oscilloscope so its top side is down on the work surface and its front is facing you.
 2. Disconnect the delay line from its holder and at connector J68 on the Analog board.
 3. Disconnect the cables at connectors J50 and J67 on the Analog board.
 4. Disconnect the cable to the rear panel Z-axis connector.
 5. Using Figure 6-14 as a guide, remove the four T-15 Torx® screws securing the attenuator assembly to the front of the chassis. Next remove the four T-15 Torx® screws securing the attenuator board to the chassis.
 6. Lift the attenuator assembly away from the oscilloscope to complete its removal.

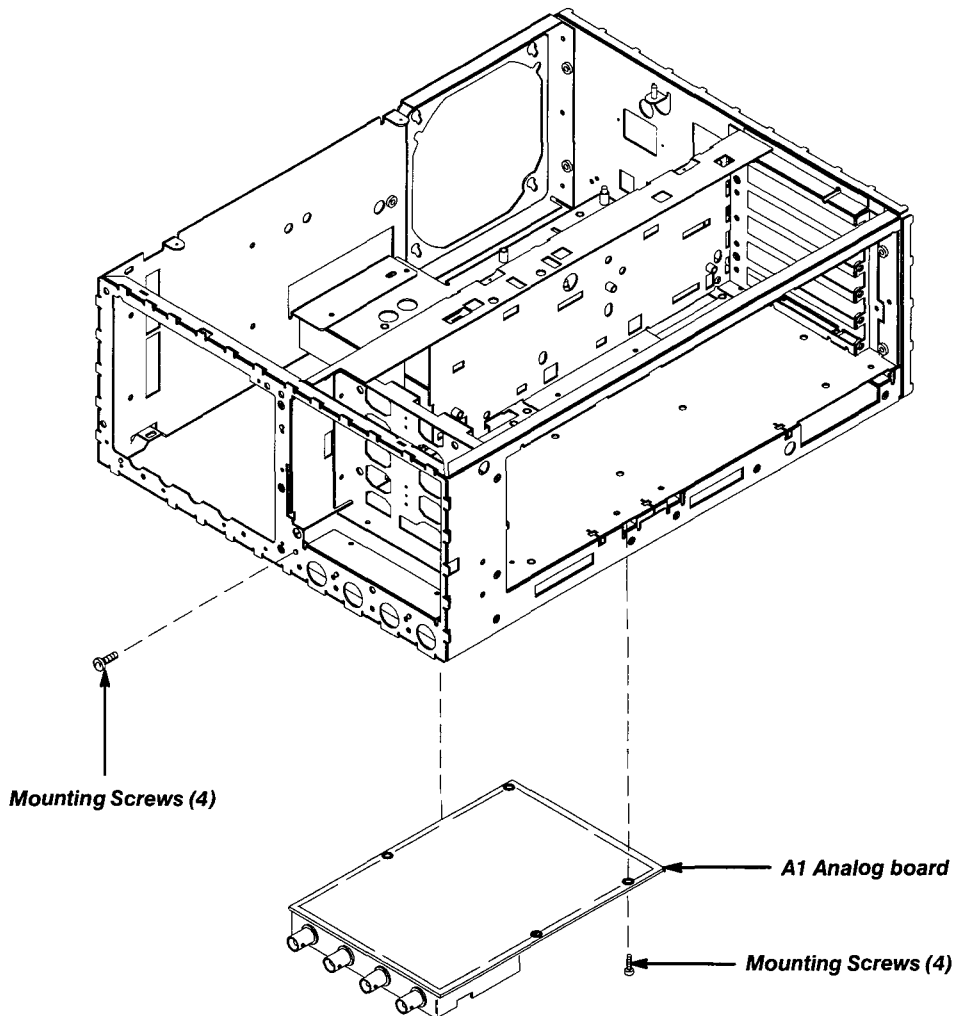

Figure 6-14: A1 Analog Board Removal

CRT Implosion Shield

The procedures that follow describe how to remove and install the CRT Implosion Shield. The method to accomplish this is different depending on the serial number of your instrument. Choose the correct procedure for your instrument by comparing your instrument serial number to those listed.

Current Method—The following procedures describe the removal of the CRT Implosion Shield for the instrument models described in the following note.

NOTE

TAS 475 — SN: B010571 and Above

TAS 485 — SN: B010329 and Above

Removal and Installation Procedures

Additional procedures required — This procedure requires that the following procedures be performed first:

- Rear Cover Removal
 - Cabinet Removal
 - Front Trim Removal
1. From the front of the Implosion Shield, slip the spudger into the slot provided on the side of the CRT Front Bracket. See Figure 6-15.
 2. Carefully pry the Implosion Shield up and out of the CRT Front Bracket guides.
 3. Re-install the Implosion Shield by placing the left side of the shield into the CRT Front Bracket guides. If installing a new Implosion Shield, remove the clear protective covers.
 4. Snap the right side of the Implosion shield into the CRT Front Bracket snaps.
 5. Install all previously removed components.

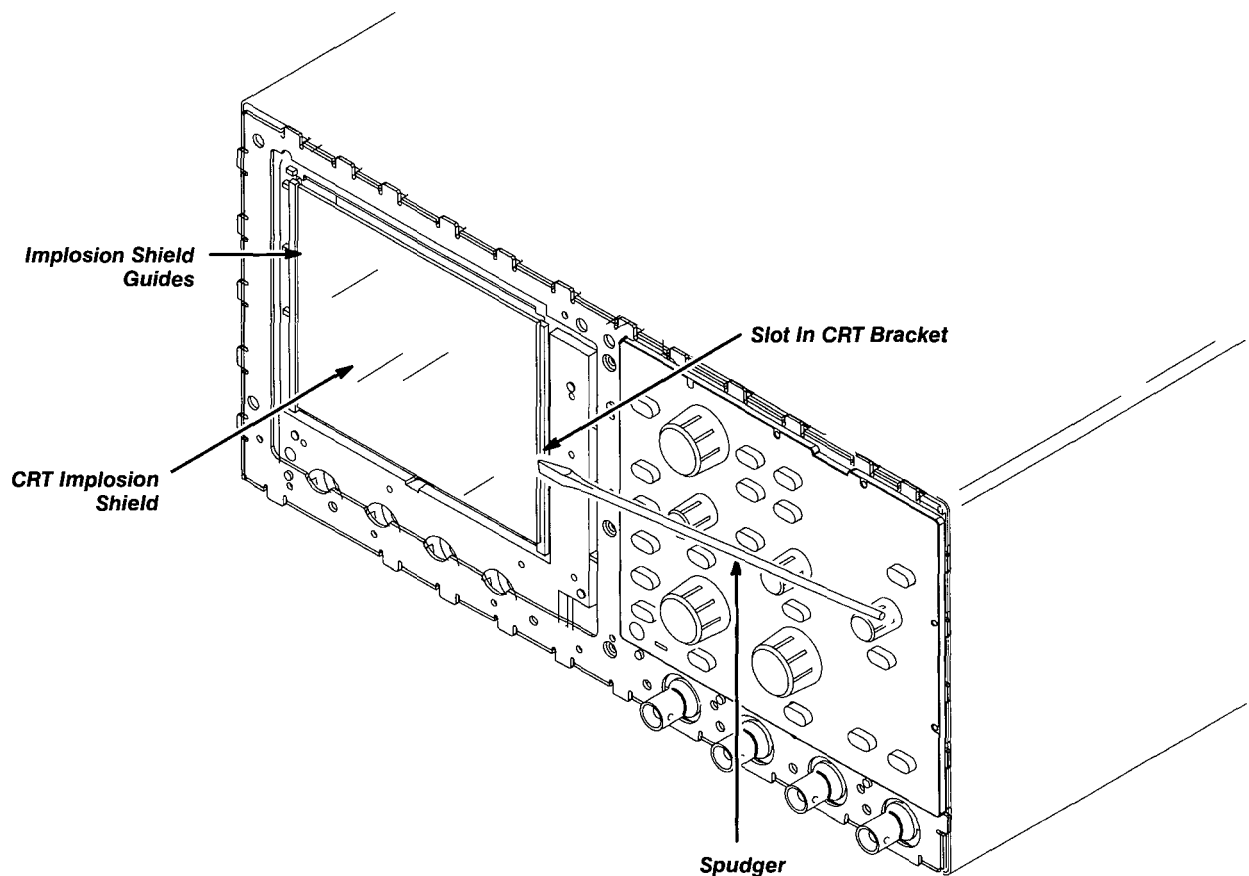

Figure 6-15: CRT Implosion Shield Removal

Early Method—The following procedures describe the removal of the CRT Implosion Shield for the instrument models described in the following note.

NOTE

TAS 475 — SN: B010570 and Below

TAS 485 — SN: B010328 and Below

Additional procedures required — This procedure requires that the following procedures be performed first:

- Rear Cover Removal
 - Cabinet Removal
 - Front Trim Removal
 - A3 Display Driver Board
 - CRT
1. From the front of the Implosion Shield, push the top of the shield until it pops out of the back side of the CRT Front Bracket.
 2. Re-install the CRT Implosion shield by snapping the shield into the rear of the CRT Front Bracket. If installing a new Implosion Shield, remove the clear protective covers.
 3. Install all previously removed components.

CRT

The procedures that follow describe how to remove and install the CRT. Refer to Figure 6-17 for this procedure.

Additional procedures required — This procedure requires that the following procedures be performed first:

- Rear Cover Removal
- Cabinet Removal
- Front Trim Removal
- A3 Display Driver Board

CRT Removal

1. Set the oscilloscope so its bottom is down on the work surface, with its front facing you.

WARNING

Breaking a CRT causes it to implode, scattering glass fragments with high velocity and possibly injuring you. Wear protective clothing and safety glasses (preferably a full-face shield). Avoiding striking the CRT with or against any object.

Store the CRT with its display face down in a protected location, placing it on a soft, nonabrasive surface to prevent scratching the face plate.

2. Unplug the the 2-wide red/black cable from the A2 Display Control board.

WARNING

High-voltage is present on the anode lead. Do not touch the end of the anode lead until it has been fully discharged to ground.

3. Disconnect the red CRT anode lead from the A63 Power Supply module and immediately discharge to chassis ground.
4. Using a $\frac{5}{16}$ inch nut driver, remove the nut securing the ground wire at the rear of the CRT.
5. From the bottom of the chassis, unsnap the Rear CRT Bracket from the chassis. See Figure 6-16.

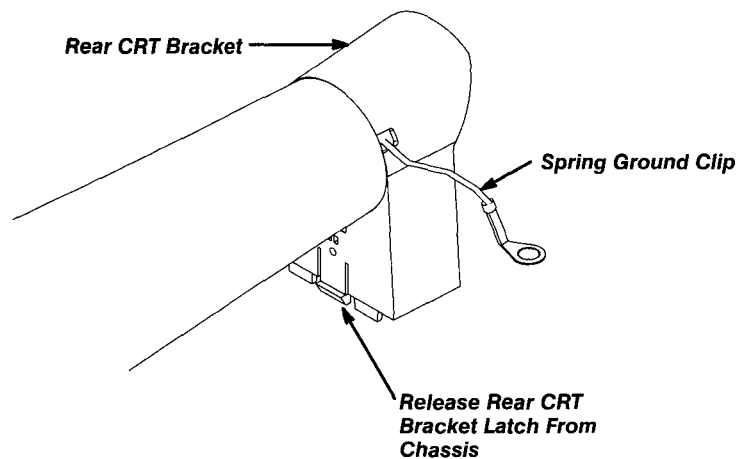

Figure 6-16: CRT Rear Bracket and Ground Clip

6. Lift the rear of the CRT until it is above the chassis. Then pull the CRT away from the CRT Front Bracket.



Stop here if you are removing the CRT assembly to gain access to other portions of the instrument. If you are installing a new CRT or hardware attached to the CRT, continue with this procedure.

7. Slide the Rear CRT Bracket from the CRT. The Spring Ground Clip will slide out also.
8. Remove the CRT Socket with its cover from the rear pin connector of the CRT.
9. Disconnect the vertical and horizontal control wires from the side of the CRT. Note the proper location of both sets of wires for reinstallation.
10. Slide the CRT shield and its front support off the CRT.
11. Store the CRT in a safe location.

CRT Installation

1. Slide the CRT shield and its front support onto the CRT as far forward as possible.
2. Align the holes in the shield so that the vertical and horizontal control pins on the side of the CRT are accessible.
3. Align the slot in the CRT Socket to the key on the CRT pin connector and slide the Socket onto the pins.
4. Slip the CRT socket wires through the Rear CRT Bracket and slide the bracket onto the rear of the CRT.
5. Ensure that the Rear CRT Bracket is properly aligned with the slots provided in the CRT Shield.
6. Slide the Spring Ground Clip into the slot provided in the Rear CRT Bracket.
7. Connect the vertical and horizontal control wires to the side CRT pins.
8. Guide the front of the CRT into the CRT Front Bracket. Ensure that the four CRT Cushions are in their proper place in each corner of the Bracket.
9. Lower the rear of the CRT into the chassis and press down on the CRT Rear Bracket until it snaps into the chassis.
10. Route the vertical and horizontal control cables to the bottom of the chassis.
11. Connect the read anode lead to its connector from the A63 Power Supply module.
12. Plug the the 2-wide red/black cable to the A2 Display Control board.
13. Install all previously removed components.

Removal and Installation Procedures

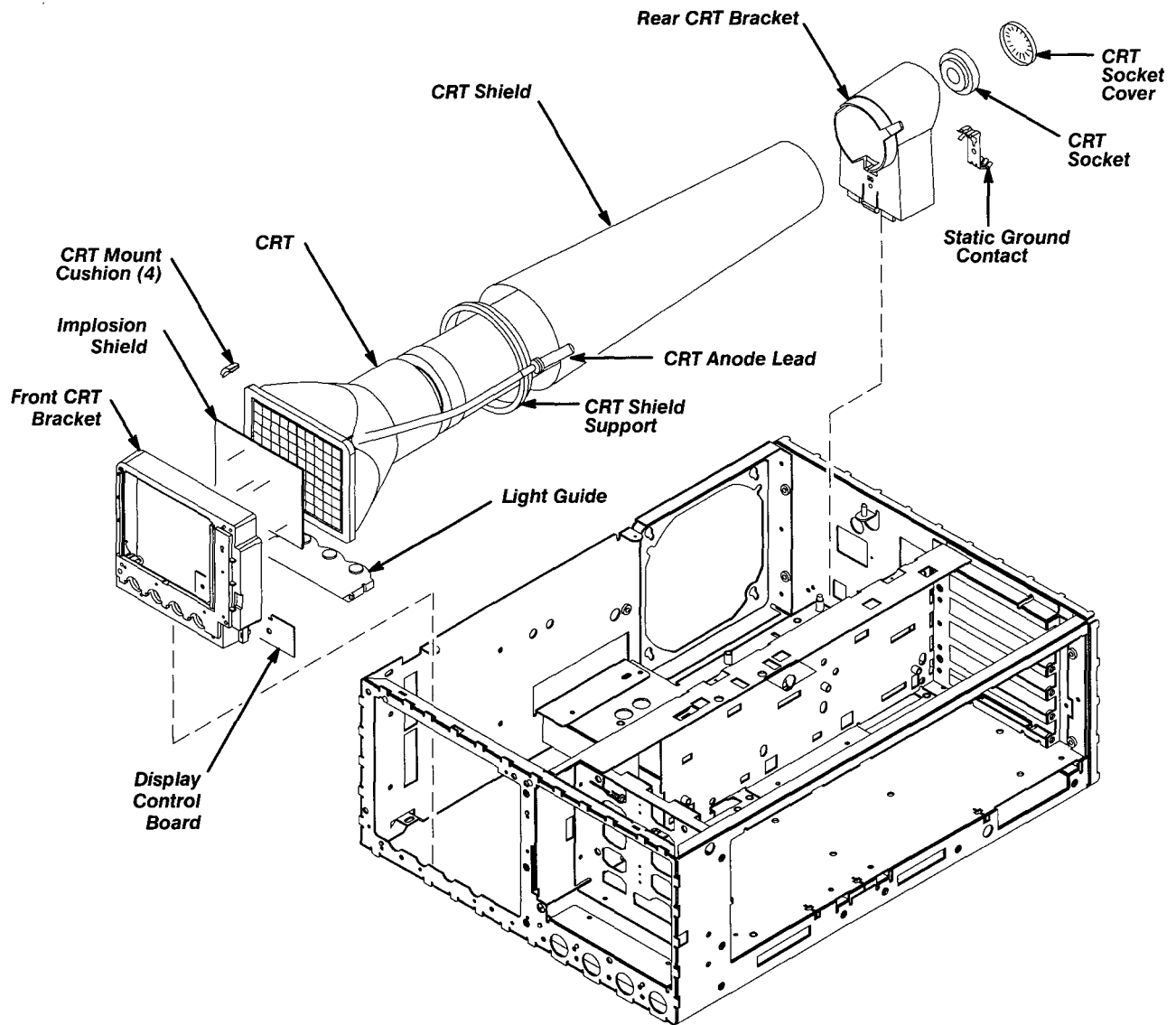

Figure 6-17: CRT Removal

CRT Light Guide

The procedures that follow describe how to remove and install the CRT Light Guide. Refer to Figure 6-17 for this procedure.

Additional procedures required — This procedure requires that the following procedures be performed first:

- Rear Cover Removal
- Cabinet Removal
- Front Trim Removal

- A3 Display Driver Board
 - CRT
1. Lift the light guide off the light bulbs on the A2 Display Control board.
 2. Re-install the light guide by sliding the guide over the light bulbs on the A2 Display Control board.

NOTE

To properly guide the light to the CRT, the beveled edge of the light guide must be facing up, toward the CRT.

3. Install all previously removed components.

CRT Front Bracket

The procedures that follow describe how to remove and install the CRT Front Bracket. Refer to Figure 6-17 for this procedure.

Additional procedures required — This procedure requires that the following procedures be performed first:

- Rear Cover Removal
 - Cabinet Removal
 - Front Trim Removal
 - A3 Display Driver Board
 - CRT
1. Remove the four screws securing the CRT front bracket to the chassis.
 2. Lift the CRT front bracket out from inside the chassis.
 3. Re-install the CRT front bracket by sliding the bracket into the chassis and secure it with the four mounting screws.
 4. Install all previously removed components.

A2 Display Control Board

The procedures that follow describe how to remove and install the CRT Front Bracket.

Additional procedures required — This procedure requires that the following procedures be performed first:

- Rear Cover Removal
- Cabinet Removal

Removal and Installation Procedures

- Front Trim Removal
 - A3 Display Driver Board
 - CRT
1. Unplug the cables from connectors J80, J82, and J84 on the A2 Display Control board.
 2. Lift the A2 Display Control board up toward the top of the chassis, sliding the board out of the board retainers.
 3. Re-install the A2 Display Control board by sliding the board into the board retainers.
 4. Re-install all cables at connectors J80, J82, and J84.
 5. Install all previously removed components.

A63 Power Supply Module

The procedures that follow describe how to remove and install the Power Supply module.

Additional procedures required — This procedure requires that the following procedures be performed first:

- Rear Cover Removal
- Cabinet Removal

Power Supply Removal

1. Set the oscilloscope so its top down on the work surface.
2. Disconnect the power button shaft from the power switch on the Power Supply module. See Figure 6-18.

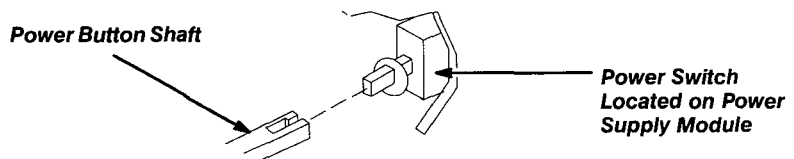

Figure 6-18: Power Button Shaft Disconnect

3. Unplug the cables going to the A3 Display Driver board at J70 and J71.
4. Set the oscilloscope so its bottom down on the work surface.
5. Unplug the cable going to the A5 CPU board at J55.
6. Unplug the two-wide cable from the fan.

7. Unplug the red CRT anode lead from the power supply connector.
8. Remove the two screws securing the Power Supply module to the chassis.
9. Lift the Power Supply module out of the chassis to complete its removal.
10. Slide the Power Supply module into the chassis, noting that the tab at the bottom of the Power Supply module slides into the slot at the bottom of the chassis.

Power Supply Installation

1. Reconnect all cables and wires disconnected during the removal procedure.
2. Re-install all components removed.

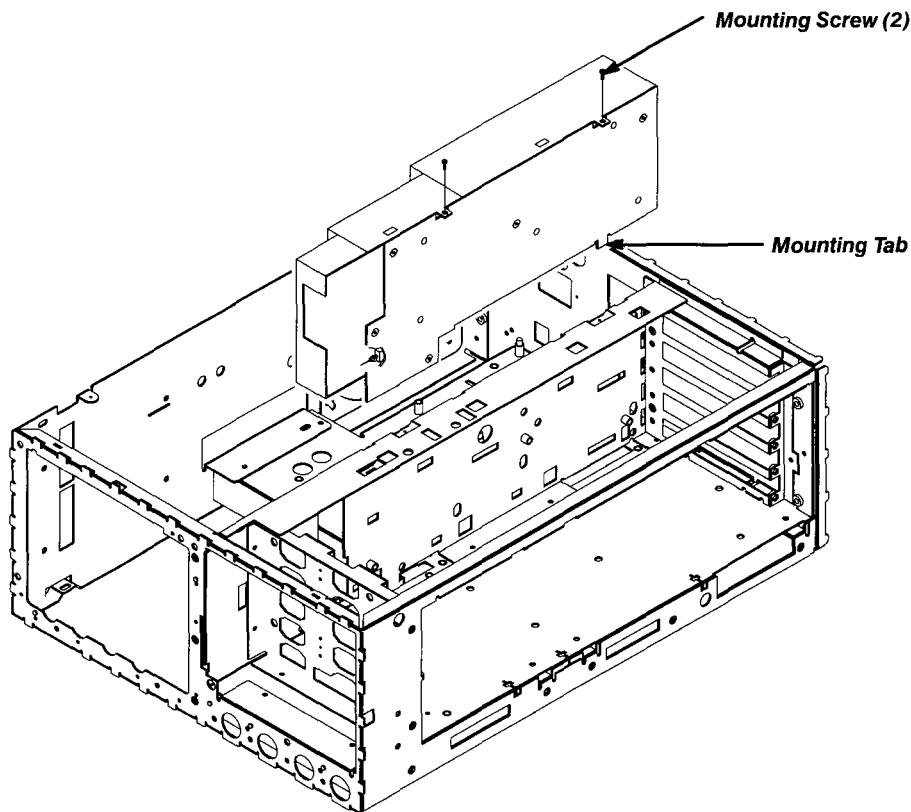

Figure 6-19: Power Supply Removal

Fan and Fan Mount

The procedures that follow describe how to remove and install the Fan and Fan Mount.

Additional procedures required — This procedure requires that the following procedures be performed first:

- Rear Cover Removal
- Cabinet Removal

Fan and Fan Mount Removal

1. Set the oscilloscope so its bottom is down.
2. Unplug the fan's power cable from the A63 Power Supply module.
3. Rotate the oscilloscope so the side that houses the fan mount is facing upwards.
4. Depress the two flex locks to release them (see Figure 6-20).
5. While holding the flex locks released, slide the fan mount so its four retainer lugs slide from their small retainer holes in the chassis into their large release holes.
6. Move the fan mount inward so its retainer lugs are out of the large retainer holes and lift the fan mount and fan it out of the chassis.

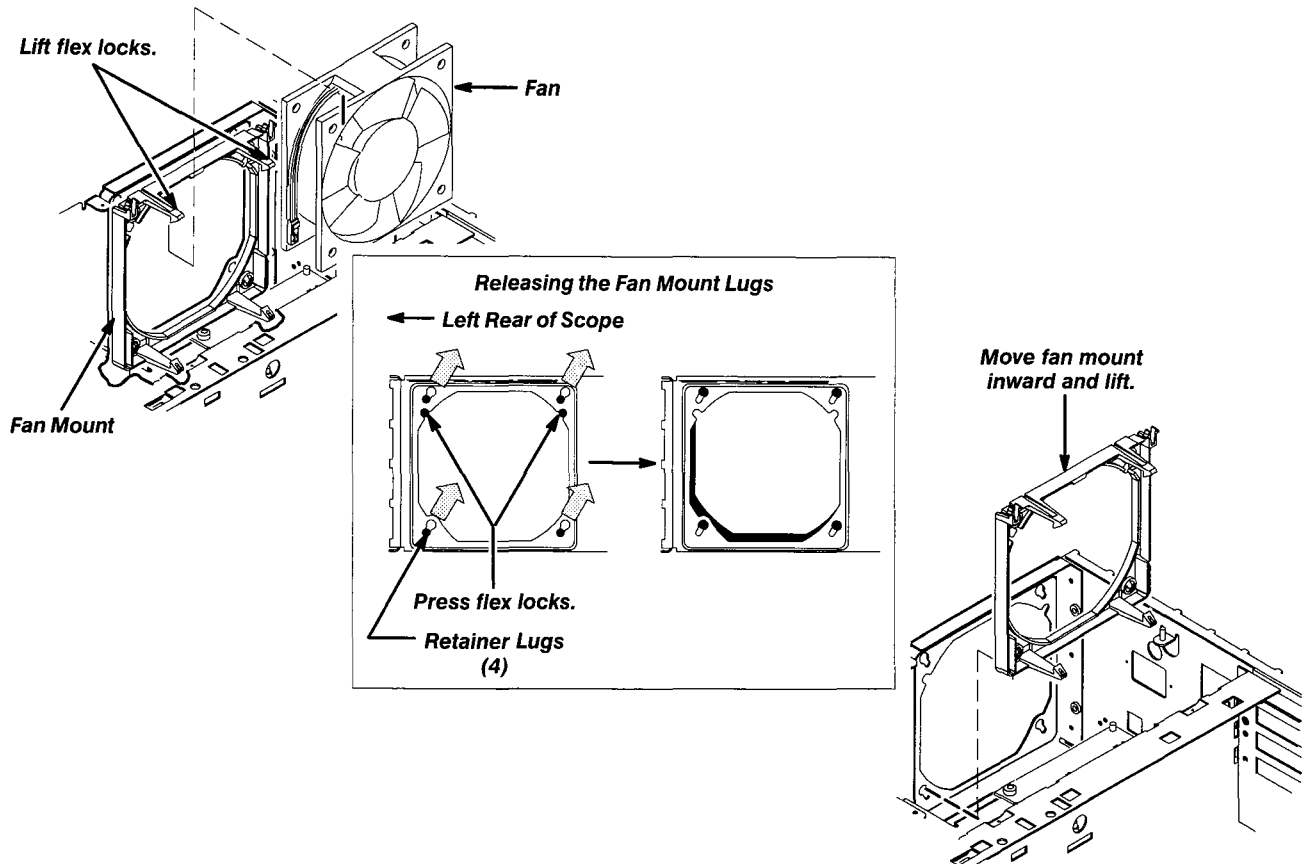

Figure 6-20: Fan and Fan Mount Removal



DO NOT remove the fan from the fan mount unless servicing a broken fan or fan mount or removing the mount for cleaning.

7. Release the two flex locks securing the top of the fan to the fan mount, then lift the fan out from the mount.

Fan and Fan Mount Installation

1. If the fan was removed from the fan mount, press the fan into the fan mount until the four retainer clips snap into place, securing the fan.
2. Install the fan assembly so that the retainer lugs on the mount are positioned in the large holes of the chassis; then, slide the fan assembly until the lugs slip into the small holes and the two flex locks snap into place.
3. Reconnect the fan's power cable.
4. Re-install all removed components.

Troubleshooting

This subsection contains information and procedures designed to help you isolate problems to a faulty module in the oscilloscope. If a module needs to be removed for repair or replacement, follow the *Removal and Installation Procedures* located in this section.

Troubleshooting Procedure

If the oscilloscope does not perform correctly, note each symptom or failure. Next, refer to the Symptom Matrix Table (Table 6-5). Locate the symptoms that most closely resemble the symptoms you noted. If there are multiple symptoms, use a process of elimination to reduce the number of possible faulty modules. Identify possible faulty modules, then perform the troubleshooting procedure/s indicated.

The cabinet must be removed to gain access to the modules for measuring signals and voltages. Refer to the *Removal and Installation Procedures* beginning on page 6-9 for instructions to remove the cabinet.

Equipment

Table 6-4 list the equipment is required to perform the troubleshooting procedures.

Table 6-4: Equipment Required for Troubleshooting

Equipment	Example
Test Oscilloscope	Tektronix TAS 465
Digital Multimeter (DMM)	Tektronix DM250
High Voltage Probe	Fluke Model 80K-40



High voltages are present when the cabinet is removed. Do not remove the high voltage shield from the A3 Display Driver board unless it is necessary to measure the high voltage. Do not perform this procedure without the presence of another person who is cable of providing aid.

Symptom Matrix

The Symptom Matrix (Table 6-5) is an aid in determining which modules to troubleshoot. There is no separate troubleshooting procedure for the power supply, since each module troubleshooting procedure includes checks of the power supply. The CRT is checked in the display control and display driver troubleshooting procedures.

The ● indicates the troubleshooting procedure most likely to locate the failed module. The ○ indicates additional troubleshooting procedures that may help locate the failed module.

Table 6-5: Symptom Matrix

Symptom	Processor	Analog	Display Driver	Front Panel	Display Control
Display Problems					
No display at all	○	○	○	○	●
Traces or readout, but not both	○	●		○	○
Abnormal readout	●	○			
Abnormal traces	○	●			
Abnormal traces and readout	○	○	●		
Power-on diagnostics indicates a failure	●	●		○	
Self-calibration does not pass	○	●			
Volts/Div and Sec/Div controls					
One control works but not both	○	●		○	
Neither control works	○	○		●	
No control of Volts/Div or vertical position of a single channel	○	●			
No control of Volts/Div or vertical position of any channels	○	○		●	
Intensity Control Problems					
No control of readout and trace intensity	○	○		●	
Control of readout or trace intensity but not both		●		○	
Focus Problems					
No control of focus			○		●
Unable to focus properly			●		○
No control of trace rotation					●
No control of scale illumination					●

Table 6-5: Symptom Matrix (Cont.)

Symptom	Processor	Analog	Display Driver	Front Panel	Display Control
Trigger level, vertical position, and horizontal position					
The trace position controls nor the Trigger Level control works	<input type="radio"/>	<input type="radio"/>		<input checked="" type="radio"/>	
Some of these controls work but not all	<input type="radio"/>	<input checked="" type="radio"/>		<input type="radio"/>	
Probe Scale (X10) Problems					
Volts/Div readout does not change with a X10 probe on any channel				<input checked="" type="radio"/>	
Front Panel Control Problems					
Front panel controls do not work but readout display works	<input type="radio"/>			<input checked="" type="radio"/>	
Front panel controls do not work and the readout display is abnormal	<input checked="" type="radio"/>			<input type="radio"/>	
CRT Bezel buttons do not work but other buttons and knobs work				<input checked="" type="radio"/>	
Front panel LED Problems					
No LED's momentarily light at power-on but readout is okay	<input type="radio"/>			<input checked="" type="radio"/>	
No LED's momentarily light at power-on and abnormal readout	<input checked="" type="radio"/>			<input type="radio"/>	
Some LED's momentarily light at power-on, but not all do				<input checked="" type="radio"/>	
No trigger on line source	<input type="radio"/>	<input checked="" type="radio"/>	<input type="radio"/>		

Troubleshooting

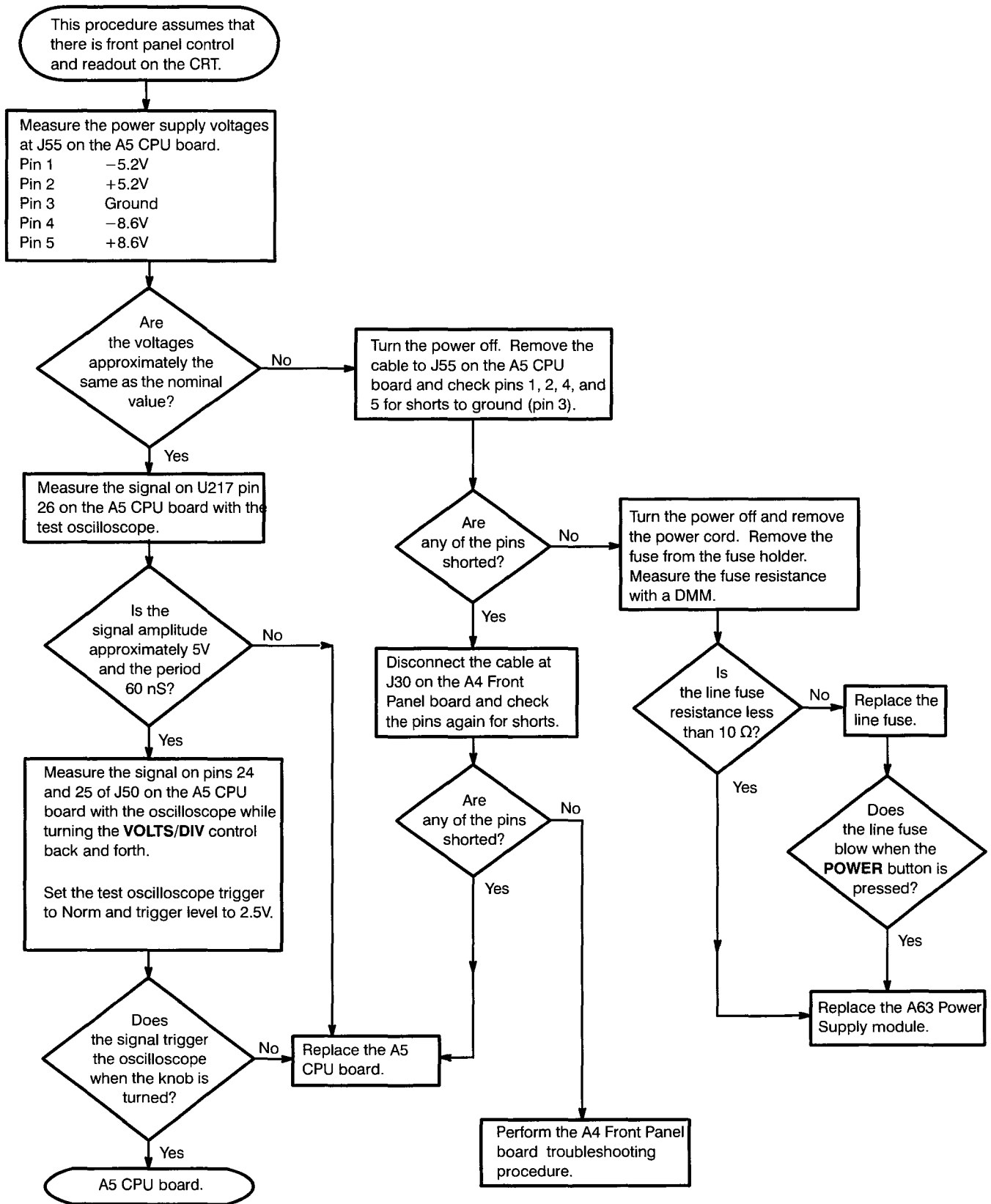

Figure 6-21: A5 CPU Board Troubleshooting Procedure

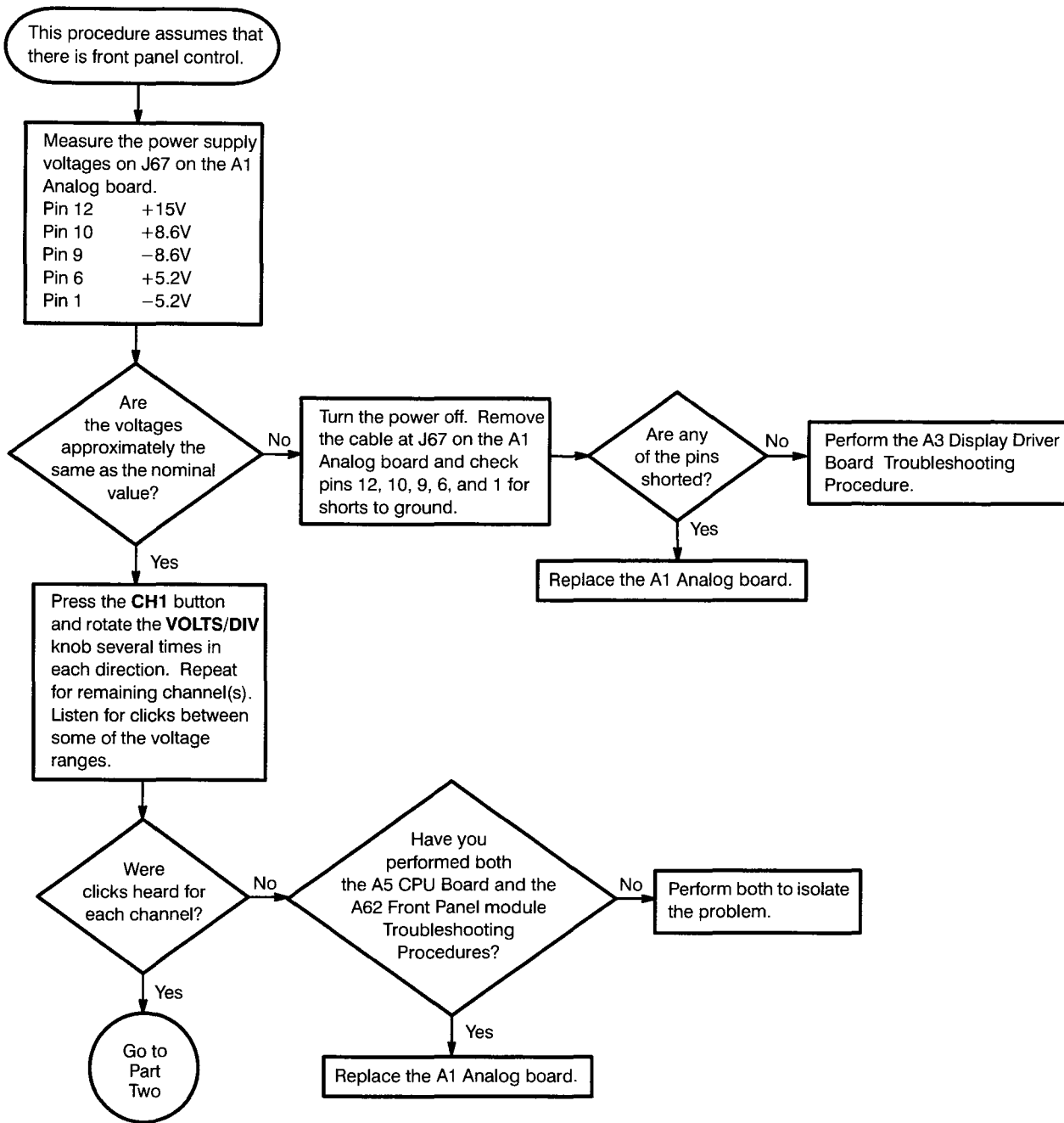

Figure 6-22: A1 Analog Board Troubleshooting Procedure

Troubleshooting

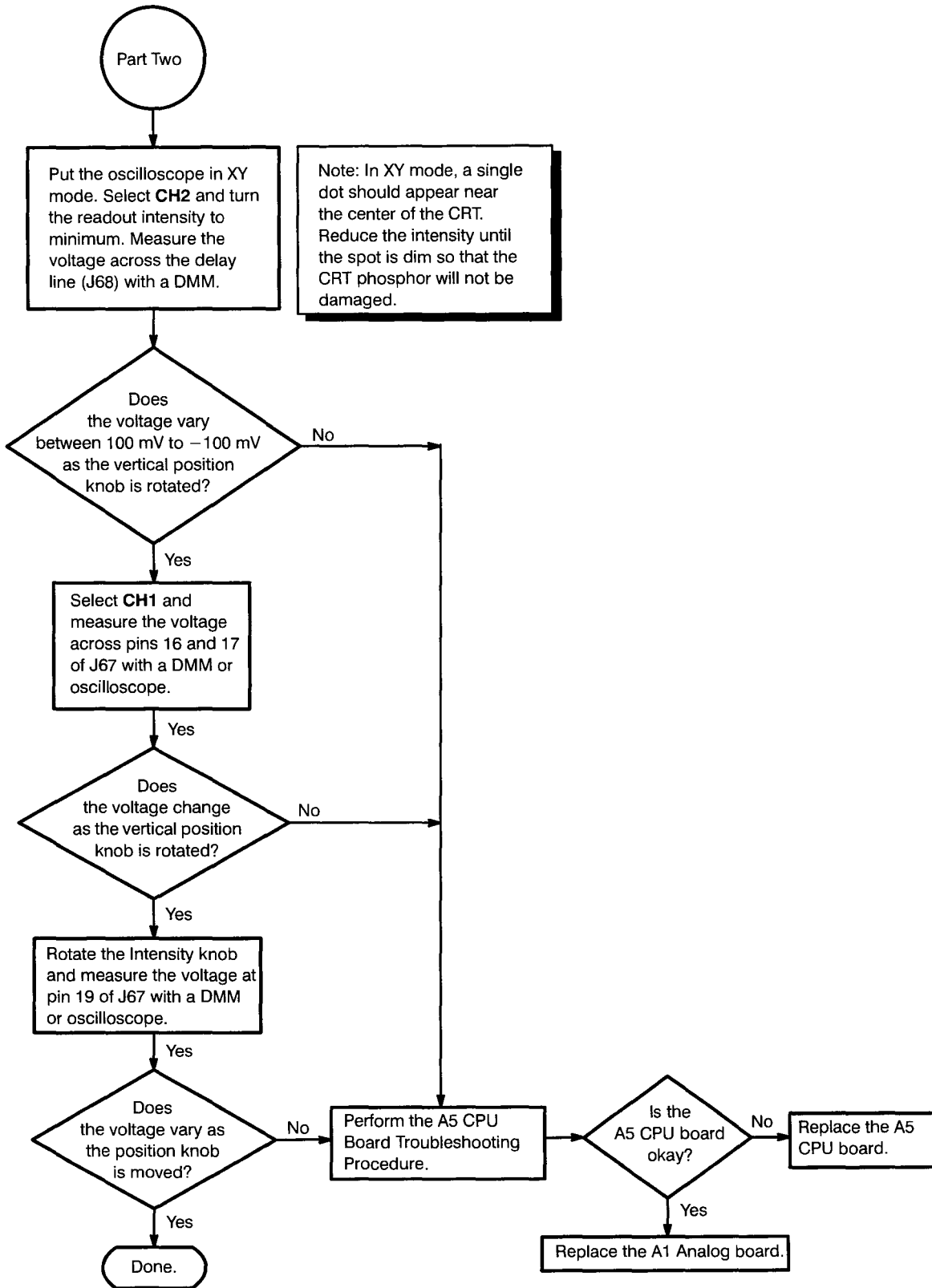

Figure 6-22: A1 Analog Board Troubleshooting Procedure (Cont.)

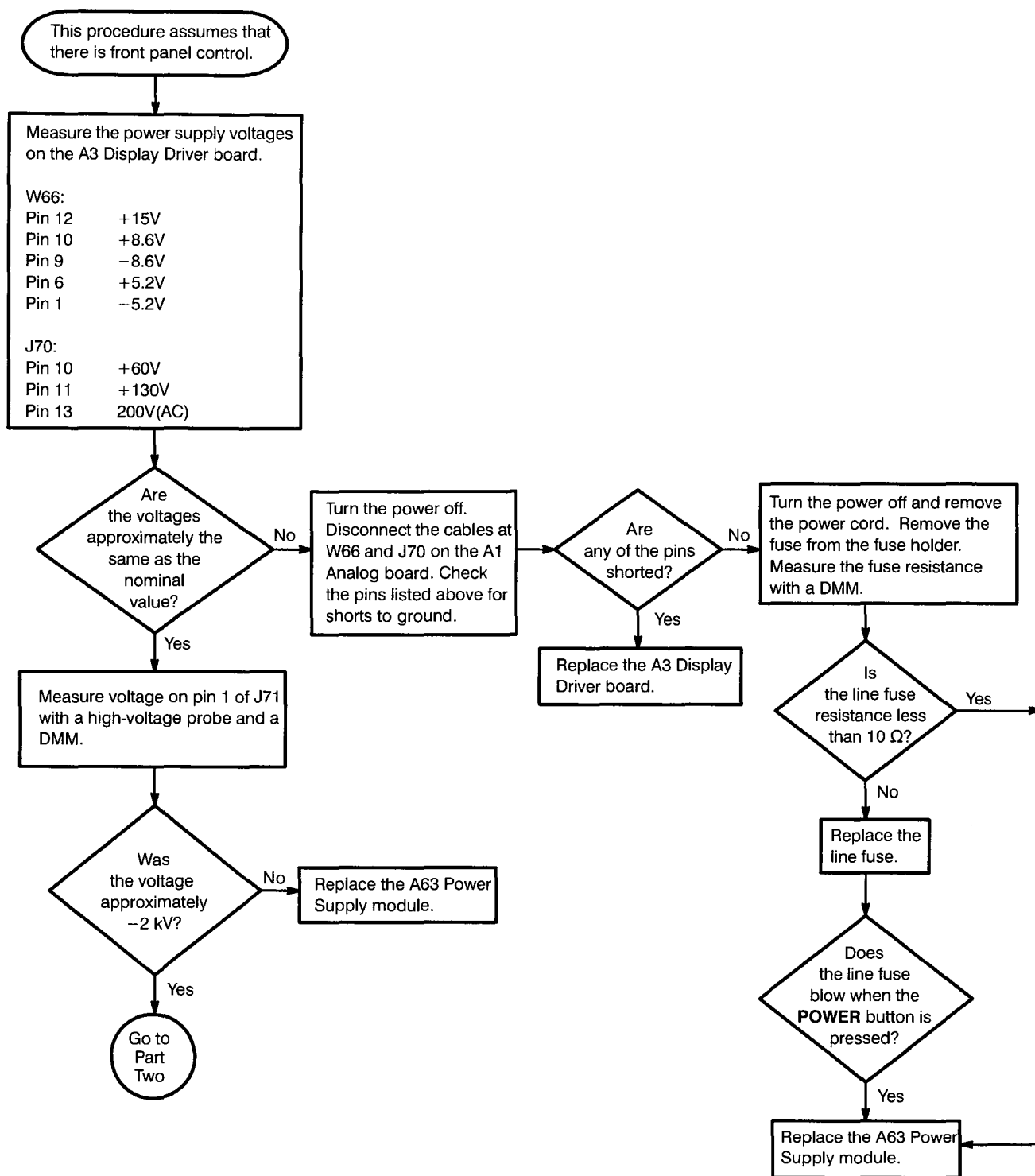

Figure 6-23: A3 Display Driver Board Troubleshooting Procedure

Troubleshooting

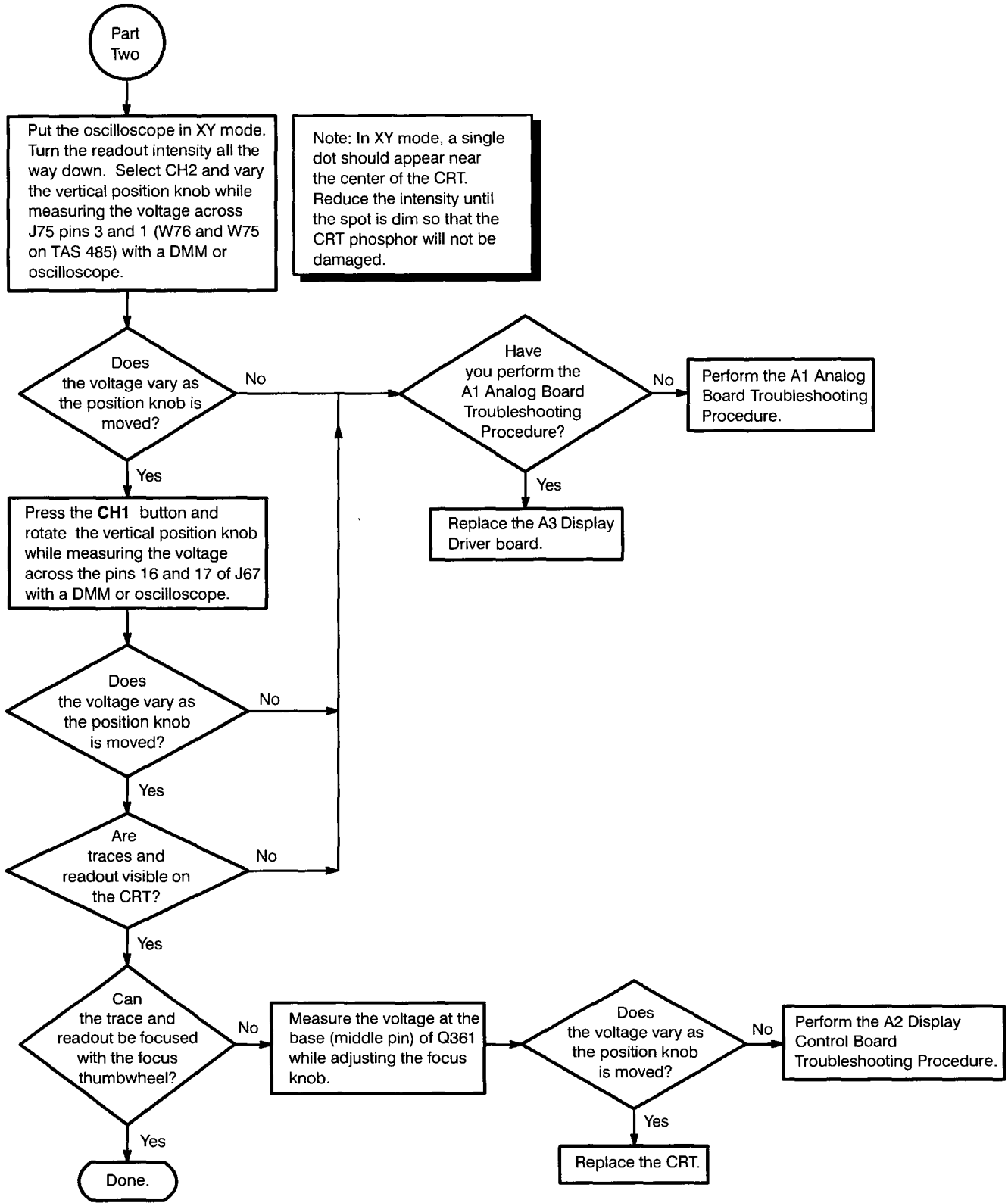

Figure 6-23: A3 Display Driver Board Troubleshooting Procedure (Cont.)

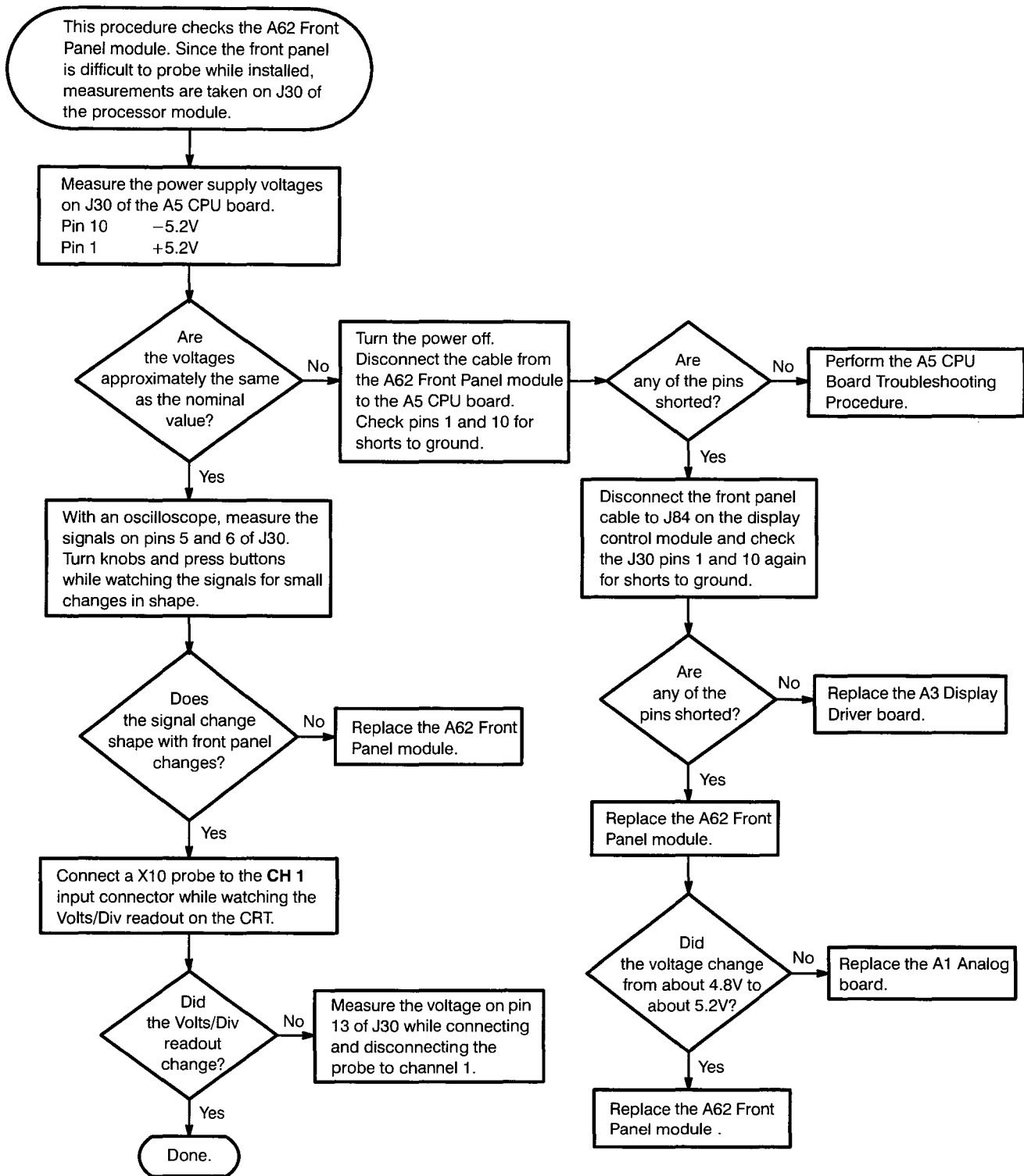

Figure 6-24: A62 Front Panel module Troubleshooting Procedure

Troubleshooting

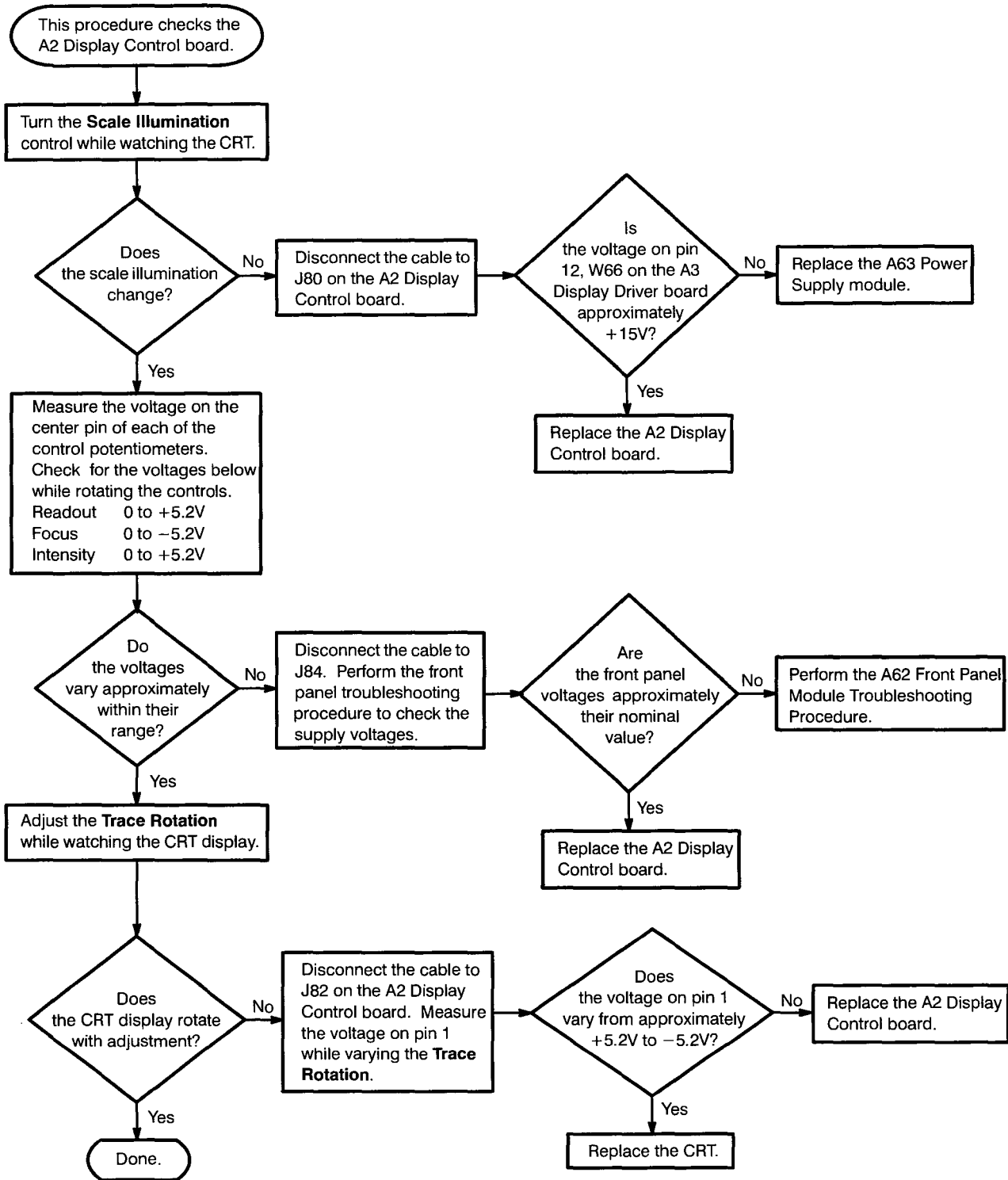

Figure 6-25: A2 Display Control Board Troubleshooting Procedure

Repackaging Information

If you ship the TAS 475 or TAS 485, pack it in the original shipping carton and packing material. If the original packing material is not available, package the instrument as follows:

1. Obtain a corrugated cardboard shipping carton with inside dimensions at least 15 cm (6 in) taller, wider, and deeper than the TAS 475 or TAS 485. The shipping carton must be constructed of cardboard with 170 kg (375 pound) test strength.
2. If you are shipping the TAS 475 or TAS 485 to a Tektronix field office for repair, attach a tag to the oscilloscope showing the instrument owner and address, the name of the person to contact about the instrument, the instrument type, and the serial number.
3. Wrap the oscilloscope with polyethylene sheeting or equivalent material to protect the finish.
4. Cushion the oscilloscope in the shipping carton by tightly packing dunnage or urethane foam on all sides between the carton and the oscilloscope. Allow 7.5 cm (3 in) on all sides, top, and bottom.
5. Seal the shipping carton with shipping tape or an industrial stapler.

Options

Several options are available for the TAS 475 and TAS 485 Analog Oscilloscopes. This section contains a list of options available.

Options A1 – A5: International Power Cords

Besides the standard North American, 110 V, 60 Hz power cord, Tektronix ships any of five alternate power cord configurations. See Table 7-1.

Table 7-1: International Power Cords

Option	Power Cord
A1	Universal European — 220 V, 50 Hz
A2	UK — 240 V, 50 Hz
A3	Australian — 240 V, 50 Hz
A4	North American — 240 V, 60 Hz
A5	Switzerland — 220 V, 50 Hz

Warranty-Plus Service Options

The following options add to the services available with the standard warranty. (The standard warranty appears following the title page in this manual.)

- **Option M2:** Tektronix provides five years of warranty/remedial service.
- **Option M3:** Tektronix provides five years of warranty/remedial service and four oscilloscope calibrations.
- **Option M8:** Tektronix provides four calibrations and four performance verifications, one of each in the second through the fifth years of service.

Option 3R: Rackmount

With this option, Tektronix ships the oscilloscope with a rackmount kit, providing all the necessary hardware to adapt the oscilloscope for installation into a standard 19 inch instrument rack. Customers with instruments can order a rackmount kit (Tektronix part number 016-1166-00) for conversion with instructions.

Option 02: Front Cover and Pouch

With this option, Tektronix ships a protective front cover to prevent damage to the front panel of the oscilloscope while not in use. An attachable pouch (attaches to the instrument top) provides storage for the manuals and probes supplied with your oscilloscope plus other additional accessories you may want to keep with your oscilloscope.

With this option, Tektronix ships two P6129B 1X — 10X switchable passive probes in addition to the two standard-accessory P6109B probes normally shipped with the instrument.

Option 9C: Certificate of Calibration and Test Data Report

Tektronix ships a Certificate of Calibration that states this instrument meets or exceeds all warranted specifications and has been calibrated using standards and instruments whose accuracies are traceable to the National Institute of Standards and Technology, an accepted value of a natural physical constant or a ratio calibration technique. The calibration is in compliance with U.S. MIL—STD—45662A. This option also includes a test data report for the instrument.

Replaceable Electrical Parts

Parts Ordering Information

Replacement parts are available from or through your local Tektronix, Inc. Field Office or representative.

When ordering parts, include the following information in your order: part number, instrument type or number, serial number, and modification number if applicable.

If a part you have ordered has been replaced with a new or improved part, your local Tektronix, Inc. Field Office or representative will contact you concerning any change in part number.

Change information, if any, is located at the rear of this manual.

List of Assemblies

A list of assemblies can be found at the beginning of the electrical parts list. The assemblies are listed in numerical order. When the complete component number of a part is known, this list will identify the assembly in which the part is located.

Cross Index-Mfr. Code Number to Manufacturer

The Mfg. Code Number to Manufacturer Cross Index for the electrical parts list is located immediately after this page. The cross index provides codes, names, and addresses of manufacturers of components listed in the electrical parts list.

Abbreviations

Abbreviations conform to American National Standard Y1.1.

Component Number

(column 1 of the parts list)

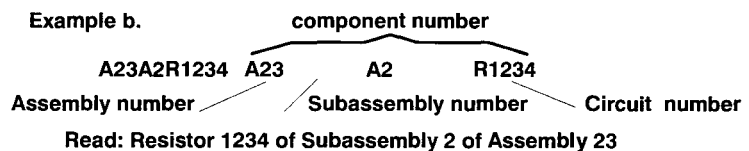
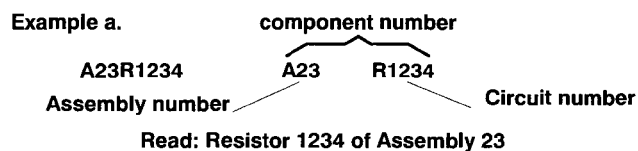

Replaceable Electrical Parts List

The circuit component's number appears on the diagrams and circuit board illustrations. Each diagram and circuit board illustration is clearly marked with the assembly number. Assembly numbers are also marked on the mechanical exploded views located in the mechanical parts list. The component number is obtained by adding the assembly number prefix to the circuit number.

The electrical parts list is divided and arranged by assemblies in numerical sequence (e.g., assembly A1 with its subassemblies and parts, precedes assembly A2 with its subassemblies and parts).

Chassis-mounted parts have no assembly number prefix and are located at the end of the electrical parts list.

Tektronix Part No.

(column 2 of the parts list)

Indicates part number to be used when ordering replacement part from Tektronix.

Serial No.

(columns 3 & 4 of the parts list)

Column three (3) indicates the serial number at which the part was first used. Column four (4) indicates the serial number at which the part was removed. No serial number entered indicates part is good for all serial numbers.

Name & Description

(column five of the parts list)

In the parts list, an item name is separated from the description by a colon (:). Because of space limitations, an item name may sometimes appear as incomplete. For further item name identification, the U.S. Federal Catalog handbook H6-1 can be utilized where possible.

Mfr. Code

(column 6 of the parts list)

Indicates the code number of the actual manufacturer of the part. (Code to name and address cross reference can be found immediately after this page.)

Mfr. Part No.

(column 7 of the parts list)

Indicates actual manufacturer's part number.

CROSS INDEX – MFR. CODE NUMBER TO MANUFACTURER

Mfr. Code	Manufacturer	Address	City, State, Zip Code
S4246	JAPAN SERVO CO LTD	7 KANDA MITOSHIRO-CHO CHIYODA-KU	TOKYO JAPAN
TK0213	TOPTRON CORP		TOKYO JAPAN
TK1146	MITSUBISHI ELECTRIC CORP	1230 OAKMEAD PARKWAY	SUNNYVALE CA 94086
TK1442	TAIYO-YUDEN (USA) INC	ARLINGTON CENTER 714 W ALGONQUIN RD	ARLINGTON HEIGHTS IL 60005
TK1492	COFER COMPONENT PROCESSING	3270 KELLER ST UNIT 11	SANTA CLARA CA 95050
TK1727	PHILIPS NEDERLAND BV AFD ELONCO	POSTBUS 90050	5600 PB EINDHOVEN THE NETHERLANDS
TK1913	WIMA THE INTER-TECHNICAL GROUP IND	ONE BRIDGE ST PO BOX 23	IRVINGTON NY 10533
TK2073	TOCOS AMERICA INC	565 W GULF ROAD	ARLINGTON HEIGHTS IL 60005
TK2469	UNITREK CORPORATION	3000 LEWIS & CLARK WAY SUITE #2	VANCOUVER WA 98601
TK6056	ASTEK USA	2880 SAN TOMES EXPRESSWAY SUITE 200	SANTA CLARA CA 95051
0B0A9	DALLAS SEMICONDUCTOR CORP	4350 BELTWOOD PKWY SOUTH	DALLAS TX 75244
0H1N5	MARCON AMERICA CORP	998 FIRST EDGE DRIVE	VERNON HILLS IL 60061
0JR03	ZMAN MAGNETICS INC	7633 S 180TH	KENT WA 98032
0JR04	TOSHIBA AMERICA INC ELECTRONICS COMPONENTS DIV BUSINESS SECTOR	2692 DOW AVE	TUSTIN CA 92680
0J7N9	MCX INC	30608 SAN ANTONIO ST	HAYWARD CA 94544
00779	AMP INC	2800 FULLING MILL PO BOX 3608	HARRISBURG PA 17105
01295	TEXAS INSTRUMENTS INC SEMICONDUCTOR GROUP	13500 N CENTRAL EXPY PO BOX 655012	DALLAS TX 75265
04222	AVX CERAMICS DIV OF AVX CORP	19TH AVE SOUTH P O BOX 867	MYRTLE BEACH SC 29577
04713	MOTOROLA INC SEMICONDUCTOR PRODUCTS SECTOR	5005 E MCDOWELL RD	PHOENIX AZ 85008-4229
05828	GENERAL INSTRUMENT CORP GOVERNMENT SYSTEMS DIV	600 W JOHN ST	HICKSVILLE NY 11802
09969	DALE ELECTRONICS INC	EAST HIGHWAY 50 P O BOX 180	YANKTON SD 57078
1CH66	PHILIPS SEMICONDUCTORS	811 E ARQUES AVENUE PO BOX 3409	SUNNYVALE CA 94088-3409
1W344	UNITED CHEMI-CON INC	9801 W HIGGINS SUITE 430	ROSEMONT IL 60018-4704
12697	CLAROSTAT MFG CO INC	LOWER WASHINGTON ST	DOVER NH 03820
14552	MICROSEMI CORP	2830 S FAIRVIEW ST	SANTA ANA CA 92704-5948
17856	SILICONIX INC	2201 LAURELWOOD RD	SANTA CLARA CA 95054-1516
18796	MURATA ERIE NORTH AMERICAN INC STATE COLLEGE OPERATIONS	1900 W COLLEGE AVE	STATE COLLEGE PA 16801-2723

Replaceable Electrical Parts List

CROSS INDEX – MFR. CODE NUMBER TO MANUFACTURER

Mfr. Code	Manufacturer	Address	City, State, Zip Code
19701	PHILIPS COMPONENTS DISCRETE PRODUCTS DIV RESISTIVE PRODUCTS FACILITY AIRPORT ROAD	PO BOX 760	MINERAL WELLS TX 76067-0760
20932	KYOCERA INTERNATIONAL INC	11620 SORRENTO VALLEY RD PO BOX 81543 PLANT NO 1	SAN DIEGO CA 92121
22526	DU PONT E I DE NEMOURS AND CO INC DU PONT ELECTRONICS DEPT	515 FISHING CREEK RD	NEW CUMBERLAND PA 17070-3007
24165	SPRAGUE ELECTRIC CO	267 LOWELL ROAD	HUDSON NH 03051
24546	BRADFORD ELECTRONICS	550 HIGH ST	BRADFORD PA 16701-3737
24931	SPECIALTY CONNECTOR CO INC	2100 EARLYWOOD DR PO BOX 547	FRANKLIN IN 46131
27014	NATIONAL SEMICONDUCTOR CORP	2900 SEMICONDUCTOR DR	SANTA CLARA CA 95051-0606
27264	MOLEX INC	2222 WELLINGTON COURT	LISLE IL 60532-1613
30983	MEPCOPAL	11468 SORRENTO VALLEY ROAD	SAN DIEGO CA 92121
32997	BOURNS INC TRIMPOT DIV	1200 COLUMBIA AVE	RIVERSIDE CA 92507-2114
34371	HARRIS CORP HARRIS SEMICONDUCTOR PRODUCTS GROUP	200 PALM BAY BLVD PO BOX 883	MELBOURNE FL 32919
4T165	NEC ELECTRONICS USA INC ELECTRON DIV	401 ELLIS ST PO BOX 7241	MOUNTAIN VIEW CA 94039
50139	ALLEN-BRADLEY CO ELECTRONIC COMPONENTS	1414 ALLEN BRADLEY DR	EL PASO TX 79936
50434	HEWLETT-PACKARD CO OPTOELECTRONICS DIV	370 W TRIMBLE RD	SAN JOSE CA 95131
52769	SPRAGUE-GOODMAN ELECTRONICS INC	134 FULTON AVE	GARDEN CITY PARK NY 11040-5352
53387	MINNESOTA MINING MFG CO	PO BOX 2963	AUSTIN TX 78769-2963
54583	TDK ELECTRONICS CORP	12 HARBOR PARK DR	PORT WASHINGTON NY 11550
55335	JKL COMPONENTS CORP	13343 PAXTON STREET	PACOIMA CA 91331
55680	NICHICON /AMERICA/ CORP	927 E STATE PKY	SCHAUMBURG IL 60195-4526
56845	DALE ELECTRONICS INC	2300 RIVERSIDE BLVD PO BOX 74	NORFOLK NE 68701-2242
57668	ROHM CORP	8 WHATNEY PO BOX 19515	IRVINE CA 92713
61429	FOX ELECTRONICS FOX ENTERPRISES INC	PO BOX 1078	CAPE CORAL FL 33910-1078
65654	CHRISTIANA INDUSTRIES CORP	6500 N CLARK ST	CHICAGO IL 62606-4002
80009	TEKTRONIX INC	14150 SW KARL BRAUN DR PO BOX 500	BEAVERTON OR 97077-0001
84411	AMERICAN SHIZUKI CORP OGALLALA OPERATIONS	301 WEST O ST	OGALLALA NE 69153-1844
91637	DALE ELECTRONICS INC	2064 12TH AVE PO BOX 609	COLUMBUS NE 68601-3632

Component Number	Tektronix Part No.	Serial No.		Name & Description	Mfr. Code	Mfr. Part No.
		Effective	Dscont			
A1	671-2646-00	B010100	B010730	CIRCUIT BD ASSY:ANALOG (TAS475 ONLY)	80009	671264600
A1	671-2646-01	B010731		CIRCUIT BD ASSY:ANALOG (TAS475 ONLY)	80009	671264601
A1	671-2646-00	B010100	B010539	CIRCUIT BD ASSY:ANALOG (TAS485 ONLY)	80009	671264600
A1	671-2646-01	B010540		CIRCUIT BD ASSY:ANALOG (TAS485 ONLY)	80009	671264601
A2	671-2222-01			CIRCUIT BD ASSY:DISPLAY CONTROL	80009	671222201
A3	671-2904-00	B010100	B010431	CIRCUIT BD ASSY:DISPLAY DRIVER (TAS475 ONLY)	80009	671290400
A3	671-2904-01	B010432		CIRCUIT BD ASSY:DISPLAY DRIVER (TAS475 ONLY)	80009	671290401
A3	671-2647-00	B010100	B010170	CIRCUIT BD ASSY:DISPLAY DRIVER (TAS485 ONLY)	80009	671264700
A3	671-2647-01	B010171	B010230	CIRCUIT BD ASSY:DISPLAY DRIVER (TAS485 ONLY)	80009	671264701
A3	671-2647-02	B010231		CIRCUIT BD ASSY:DISPLAY DRIVER (TAS485 ONLY)	80009	671264702
A4	671-2220-00			CIRCUIT BD ASSY:FRONT PANEL	80009	671222000
A5	671-2221-01	B010100	B010160	CIRCUIT BD ASSY:CPU (TAS475 ONLY)	80009	671222101
A5	671-2221-02	B010161	B010570	CIRCUIT BD ASSY:CPU (TAS475 ONLY)	80009	671222102
A5	671-2221-03	B010571		CIRCUIT BD ASSY:CPU (TAS475 ONLY)	80009	671222103
A5	671-2221-01	B010100	B010136	CIRCUIT BD ASSY:CPU (TAS485 ONLY)	80009	671222101
A5	671-2221-02	B010137	B010320	CIRCUIT BD ASSY:CPU (TAS485 ONLY)	80009	671222102
A5	671-2221-03	B010321		CIRCUIT BD ASSY:CPU (TAS485 ONLY)	80009	671222103
A9	259-0091-00			FLEX CIRCUIT:BEZEL	80009	259009100
A62	672-1362-00			CIRCUIT BD ASSY:FRONT PANEL MODULE (TAS475 ONLY)	80009	672136200
A62	672-1395-00			CIRCUIT BD ASSY:FRONT PANEL MODULE (TAS485 ONLY)	80009	672139500
A63	119-5024-00			POWER SUPPLY:LOW POWER VERSION	TK6056	119-5024-00
A64	154-0905-01			ELECTRON TUBE:CRT (TAS475 ONLY)	80009	154090501
A64	154-0972-00			ELECTRON TUBE:CRT (TAS485 ONLY)	80009	154097200

Replaceable Electrical Parts List

Component Number	Tektronix Part No.	Serial No.		Name & Description	Mfr. Code	Mfr. Part No.
		Effective	Dscont			
A1	671-2646-00	B010100	B010730	CIRCUIT BD ASSY:ANALOG (TAS475 ONLY)	80009	671264600
A1	671-2646-01	B010731		CIRCUIT BD ASSY:ANALOG (TAS475 ONLY)	80009	671264601
A1	671-2646-00	B010100	B010539	CIRCUIT BD ASSY:ANALOG (TAS485 ONLY)	80009	671264600
A1	671-2646-01	B010540		CIRCUIT BD ASSY:ANALOG (TAS485 ONLY)	80009	671264601
A1AT401	165-2500-00			MICROCKT,HYBRID:1 M OHM ATTEN/PREAMP	80009	165250000
A1AT402	165-2500-00			MICROCKT,HYBRID:1 M OHM ATTEN/PREAMP	80009	165250000
A1AT450	165-2500-00			MICROCKT,HYBRID:1 M OHM ATTEN/PREAMP	80009	165250000
A1AT451	165-2500-00			MICROCKT,HYBRID:1 M OHM ATTEN/PREAMP	80009	165250000
A1C402	285-1471-00			CAP,FXD,PLASTIC:METALIZED FILM;0.01 MFD,10%	84411	TEK-385
A1C403	285-1472-00			CAP,FXD,PLASTIC:METALIZED FILM;10 MFD,10%	84411	TEK-385
A1C404	281-0909-00			CAP,FXD,CERAMIC:MLC;0.022UF,20%,50V	04222	SA105C223MAA
A1C405	281-0909-00			CAP,FXD,CERAMIC:MLC;0.022UF,20%,50V	04222	SA105C223MAA
A1C407	281-0909-00			CAP,FXD,CERAMIC:MLC;0.022UF,20%,50V	04222	SA105C223MAA
A1C408	281-0909-00			CAP,FXD,CERAMIC:MLC;0.022UF,20%,50V	04222	SA105C223MAA
A1C409	281-0909-00			CAP,FXD,CERAMIC:MLC;0.022UF,20%,50V	04222	SA105C223MAA
A1C410	281-0936-00	B010357		CAP,FXD,CERAMIC:MLC;39PF,5%,100V (TAS475 ONLY)	04222	SA102A390JAA
A1C410	281-0936-00	B010231		CAP,FXD,CERAMIC:MLC;39PF,5%,100V (TAS485 ONLY)	04222	SA102A390JAA
A1C411	285-1473-00			CAP,FXD,PLASTIC:METALIZED FILM;0.1 MFD,10%	84411	TEK-385
A1C417	281-0909-00			CAP,FXD,CERAMIC:MLC;0.022UF,20%,50V	04222	SA105C223MAA
A1C423	290-1198-00			CAP,FXD,ELCTL:100UF,20%,10VAC	55680	UET1A101MPH
A1C426	290-1198-00			CAP,FXD,ELCTL:100UF,20%,10VAC	55680	UET1A101MPH
A1C427	281-0909-00			CAP,FXD,CERAMIC:MLC;0.022UF,20%,50V	04222	SA105C223MAA
A1C429	290-0944-01			CAP,FXD,ELCTL:220UF,20%,10V	0H1N5	CEBSM1C221M-T4
A1C430	283-0177-00			CAP,FXD,CER DI:1UF,+80-20%,25V	04222	SR303E105ZAA
A1C431	290-0944-01			CAP,FXD,ELCTL:220UF,20%,10V	0H1N5	CEBSM1C221M-T4
A1C432	290-0944-01			CAP,FXD,ELCTL:220UF,20%,10V	0H1N5	CEBSM1C221M-T4
A1C436	281-0791-00			CAP,FXD,CERAMIC:MLC;270PF,10%,100V	04222	SA102C271KAA
A1C437	290-1198-00			CAP,FXD,ELCTL:100UF,20%,10VAC	55680	UET1A101MPH
A1C438	283-0167-02	B010100	B012452	CAP,FXD,CER DI:0.1UF,10%,100V (TAS455 ONLY)	04222	SR591C104KAAAP1
A1C438	283-0177-05	B012453		CAP,FXD,CER DI:1UF,+80-20%,25V SQUARE,MI (TAS455 ONLY)	04222	SR303E105ZAAAP1
A1C438	283-0167-02	B010100	B011959	CAP,FXD,CER DI:0.1UF,10%,100V (TAS465 ONLY)	04222	SR591C104KAAAP1
A1C438	283-0177-05	B011960		CAP,FXD,CER DI:1UF,+80-20%,25V SQUARE,MI (TAS465 ONLY)	04222	SR303E105ZAAAP1
A1C450	281-0909-00			CAP,FXD,CERAMIC:MLC;0.022UF,20%,50V	04222	SA105C223MAA
A1C451	281-0909-00			CAP,FXD,CERAMIC:MLC;0.022UF,20%,50V	04222	SA105C223MAA
A1C452	281-0909-00			CAP,FXD,CERAMIC:MLC;0.022UF,20%,50V	04222	SA105C223MAA

Component Number	Tektronix Part No.	Serial No.		Name & Description	Mfr. Code	Mfr. Part No.
		Effective	Dscont			
A1C453	281-0909-00			CAP,FXD,CERAMIC:MLC;0.022UF,20%,50V	04222	SA105C223MAA
A1C454	281-0909-00			CAP,FXD,CERAMIC:MLC;0.022UF,20%,50V	04222	SA105C223MAA
A1J10	131-3731-00			CONN,RF JACK:BNC,;50 OHM,FEMALE,ST	24931	28JR377-1
A1J11	131-3731-00			CONN,RF JACK:BNC,;50 OHM,FEMALE,STR	24931	28JR377-1
A1J20	131-3731-00			CONN,RF JACK:BNC,;50 OHM,FEMALE,STR	24931	28JR377-1
A1J21	131-3731-00			CONN,RF JACK:BNC,;50 OHM,FEMALE,STR	24931	28JR377-1
A1J50	131-5346-00			CONN,HDR:PCB,;MALE,STR,2 X 20,0.1 CTR	00779	104338-8
A1J66	131-5419-00			CONN,HDR:PCB,;MALE,STR,1 X 2,0.1 CTR	00779	644486-2
A1J67	131-5347-00			CONN,HDR:PCB,;MALE,RTANG,1 X 23,0.1 CTR	00779	2-103673-2
A1J68	131-5419-00			CONN,HDR:PCB,;MALE,STR,1 X 2,0.1 CTR	00779	644486-2
A1L401	108-1319-00			INDUCTOR,FIXED:33UH,10%,1.8A	54583	TSL1110-330K 1R
A1L402	108-1319-00			INDUCTOR,FIXED:33UH,10%,1.8A	54583	TSL1110-330K 1R
A1L403	108-1352-00			COIL,RF:FIXED,22UH,10%	54583	SPT0305-220K
A1L404	108-1352-00			COIL,RF:FIXED,22UH,10%	54583	SPT0305-220K
A1L405	108-1319-00			INDUCTOR,FIXED:33UH,10%,1.8A	54583	TSL1110-330K 1R
A1L406	108-1319-00			INDUCTOR,FIXED:33UH,10%,1.8A	54583	TSL1110-330K 1R
A1Q401	151-0830-00			TRANSISTOR,SIG:BIPOLAR,NPN;15V,50MA,600MHZ	27014	4392/X43153A
A1Q402	151-0830-00			TRANSISTOR,SIG:BIPOLAR,NPN;15V,50MA,600MHZ	27014	4392/X43153A
A1Q403	151-0830-00			TRANSISTOR,SIG:BIPOLAR,NPN;15V,50MA,600MHZ	27014	4392/X43153A
A1R402	313-1103-00			RES,FXD,FILM:10K OHM,5%,0.2W	91637	CCF50-2-10001J
A1R403	313-1103-00			RES,FXD,FILM:10K OHM,5%,0.2W	91637	CCF50-2-10001J
A1R404	313-1103-00			RES,FXD,FILM:10K OHM,5%,0.2W	91637	CCF50-2-10001J
A1R413	313-1103-00			RES,FXD,FILM:10K OHM,5%,0.2W	91637	CCF50-2-10001J
A1R415	313-1102-00			RES,FXD,FILM:1K OHM,5%,0.2W	91637	CCF50-2-10000J
A1R417	313-1102-00			RES,FXD,FILM:1K OHM,5%,0.2W	91637	CCF50-2-10000J
A1R418	313-1102-00			RES,FXD,FILM:1K OHM,5%,0.2W	91637	CCF50-2-10000J
A1R419	313-1390-00			RES,FXD,FILM:39 OHM,5%,0.2W	91637	CCF50-2-39R00J
A1R421	313-1015-00			RES,FXD,FILM:1.5 OHM,5%,0.2W	57668	TR20JT6801E5
A1R423	313-1015-00			RES,FXD,FILM:1.5 OHM,5%,0.2W	57668	TR20JT6801E5
A1R424	313-1015-00			RES,FXD,FILM:1.5 OHM,5%,0.2W	57668	TR20JT6801E5
A1R425	313-1101-00			RES,FXD,FILM:100 OHM,5%,0.2W	91637	CCF50-2-100R0J
A1R426	313-1082-00			RES,FXD,FILM:8.2 OHM,5%,0.2W	91637	CCF50-2-8R200J;
A1R427	313-1102-00			RES,FXD,FILM:1K OHM,5%,0.2W	91637	CCF50-2-10000J
A1R428	313-1683-00			RES,FXD,FILM:68K OHM,5%,0.2W	91637	CCF50-2-68001J
A1R429	322-3260-00			RES,FXD,FILM:4.99K OHM,1%,0.2W	91637	CCF501G49900F
A1R430	313-1102-00			RES,FXD,FILM:1K OHM,5%,0.2W	91637	CCF50-2-10000J
A1R450	313-1102-00			RES,FXD,FILM:1K OHM,5%,0.2W	91637	CCF50-2-10000J
A1R451	313-1102-00			RES,FXD,FILM:1K OHM,5%,0.2W	91637	CCF50-2-10000J
A1U403	156-0355-00			IC,LINEAR:7-TRANSISTOR,COMMON EMITTER	34371	CA3081
A1U404	156-0355-00			IC,LINEAR:7-TRANSISTOR,COMMON EMITTER	34371	CA3081

Replaceable Electrical Parts List

Component Number	Tektronix Part No.	Serial No.		Name & Description	Mfr. Code	Mfr. Part No.
		Effective	Dscont			
A1U405	165-2446-00	B010100	B010356	MICROCKT, HYBRID: ANALOG/TRIGGER/SWEEP (TAS475 ONLY)	80009	165244600
A1U405	165-2446-01	B010357		MICROCKT, HYBRID: ANALOG/TRIGGER/SWEEP (TAS475 ONLY)	80009	165244601
A1U405	165-2446-00	B010100	B010230	MICROCKT, HYBRID: ANALOG/TRIGGER/SWEEP (TAS485 ONLY)	80009	165244600
A1U405	165-2446-01	B010231		MICROCKT, HYBRID: ANALOG/TRIGGER/SWEEP (TAS485 ONLY)	80009	165244601
A1U406	156-2605-00			IC, MISC: HCMOS, ANALOG MUX; 8 CHAN, 125 OHM	04713	MC74HC4051N/J
A1U407	156-1631-01			IC, LINEAR: BIPOLAR, VOLT REG; ADJ, 100MA, 2.2%	01295	TL431CLPM
A1U450	156-0355-00			IC, LINEAR: 7-TRANSISTOR, COMMON EMITTER	34371	CA3081
A1U451	156-0355-00			IC, LINEAR: 7-TRANSISTOR, COMMON EMITTER	34371	CA3081
A1W429	196-3064-00			LEAD, ELECTRICAL: 26 AWG, 4.0 L, 1-N	80009	196306400

Component Number	Tektronix Part No.	Serial No.		Name & Description	Mfr. Code	Mfr. Part No.
		Effective	Dscont			
A2	671-2222-01			CIRCUIT BD ASSY:DISPLAY CONTROL	80009	67122201
A2C1	281-0909-00			CAP,FXD,CERAMIC:MLC;0.022UF,20%,50V	04222	SA105C223MAA
A2DS1	150-0168-00			LAMP,INCAND:14V,0.08A,WEDGE BASE	55335	73
A2DS3	150-0168-00			LAMP,INCAND:14V,0.08A,WEDGE BASE	55335	73
A2J80	131-5156-00			CONN,HDR:PCB,;MALE,STR,1 X 2,0.1 CTR	00779	103669-1
A2J82	131-0608-00			TERMINAL,PIN:PRESSFIT/PCB,;MALE,STR (QTY 2)	22526	48283-018
A2J84	131-5157-00			CONN,HDR:PCB,;MALE,STR,1 X 5,0.1 CTR	00779	103669-4
A2Q1	151-0736-00			TRANSISTOR,SIG:BIPOLAR,NPN;40V,600MA	0JR04	2N4401
A2Q3	151-0736-00			TRANSISTOR,SIG:BIPOLAR,NPN;40V,600MA	0JR04	2N4401
A2R1	313-1051-00			RES,FXD,FILM:5.1 OHM,5%,0.2W	91637	CT3-5R100J
A2R3	313-1051-00			RES,FXD,FILM:5.1 OHM,5%,0.2W	91637	CT3-5R100J
A2R4	311-2501-00			RES,VAR,TRMR:CERMET;2K OHM,20%,0.5W	32997	3386P-FE7-202
A2R5	311-2344-00			RES,VAR,NONWW:CKT BD,4.7K OHM,20%,1.25W	30983	P2322-510-90062
A2R6	311-2344-00			RES,VAR,NONWW:CKT BD,4.7K OHM,20%,1.25W	30983	P2322-510-90062
A2R7	311-1500-00			RES,VAR,NONWW:PNL,5K OHM,0.5W	12697	W-8097
A2R8	311-2344-00			RES,VAR,NONWW:CKT BD,4.7K OHM,20%,1.25W	30983	P2322-510-90062
A2R9	311-2344-00			RES,VAR,NONWW:CKT BD,4.7K OHM,20%,1.25W	30983	P2322-510-90062
A2X1	352-1008-00			HOLDER,LAMP:PRESS-IN MOUNT,RIGHT ANGLE	65654	CIC 6500L
A2X3	352-1008-00			HOLDER,LAMP:PRESS-IN MOUNT,RIGHT ANGLE	65654	CIC 6500L

Replaceable Electrical Parts List

Component Number	Tektronix Part No.	Serial No.		Name & Description	Mfr. Code	Mfr. Part No.
		Effective	Dscont			
A3	671-2904-00	B010100	B010431	CIRCUIT BD ASSY:DISPLAY DRIVER (TAS475 ONLY)	80009	671290400
A3	671-2904-01	B010432		CIRCUIT BD ASSY:DISPLAY DRIVER (TAS475 ONLY)	80009	671290401
A3	671-2647-00	B010100	B010170	CIRCUIT BD ASSY:DISPLAY DRIVER (TAS485 ONLY)	80009	671264700
A3	671-2647-01	B010171	B010230	CIRCUIT BD ASSY:DISPLAY DRIVER (TAS485 ONLY)	80009	671264701
A3	671-2647-02	B010231		CIRCUIT BD ASSY:DISPLAY DRIVER (TAS485 ONLY)	80009	671264702
A3C102	281-0909-00			CAP,FXD,CERAMIC:MLC;0.022UF,20%,50V (TAS475 ONLY)	04222	SA105C223MAA
A3C102	285-1460-00			CAP,FXD,MTLZD:0.1UF,20%,250V,5MM LEAD SPAC (TAS485 ONLY)	TK1913	MKS 2 0.1/250/2
A3C104	281-0909-00			CAP,FXD,CERAMIC:MLC;0.022UF,20%,50V (TAS475 ONLY)	04222	SA105C223MAA
A3C104	283-0203-00			CAP,FXD,CER DI:0.47UF,20%,50V (TAS485 ONLY)	04222	SR305C474MAA
A3C105	281-0909-00			CAP,FXD,CERAMIC:MLC;0.022UF,20%,50V	04222	SA105C223MAA
A3C106	281-0909-00			CAP,FXD,CERAMIC:MLC;0.022UF,20%,50V (TAS475 ONLY)	04222	SA105C223MAA
A3C106	283-0203-00			CAP,FXD,CER DI:0.47UF,20%,50V (TAS485 ONLY)	04222	SR305C474MAA
A3C107	283-0203-00			CAP,FXD,CER DI:0.47UF,20%,50V	04222	SR305C474MAA
A3C108	281-0909-00			CAP,FXD,CERAMIC:MLC;0.022UF,20%,50V	04222	SA105C223MAA
A3C109	281-0762-00			CAP,FXD,CER DI:27PF,20%,100V (TAS475 ONLY)	04222	SA102A270MAA
A3C109	281-0909-00			CAP,FXD,CERAMIC:MLC;0.022UF,20%,50V (TAS485 ONLY)	04222	SA105C223MAA
A3C110	281-0762-00			CAP,FXD,CER DI:27PF,20%,100V (TAS475 ONLY)	04222	SA102A270MAA
A3C111	283-0331-00			CAP,FXD,CER DI:43PF,2%,100V (TAS475 ONLY)	18796	DD106B10NP0430J
A3C113	281-0909-00			CAP,FXD,CERAMIC:MLC;0.022UF,20%,50V	04222	SA105C223MAA
A3C116	283-0331-00			CAP,FXD,CER DI:43PF,2%,100V (TAS475 ONLY)	18796	DD106B10NP0430J
A3C118	283-0108-02			CAP,FXD,CER DI:220PF,10%,200V (TAS475 ONLY)	04222	SR075A221KAAAP1
A3C119	283-0108-02			CAP,FXD,CER DI:220PF,10%,200V (TAS475 ONLY)	04222	SR075A221KAAAP1
A3C121	281-0306-00			CAP,VAR,CER DI:3.3-20PF (TAS475 ONLY)	52769	GKU 18000
A3C121	281-0305-00			CAP,VAR,CER DI:1.5-4.0PF (TAS485 ONLY)	52769	GKU 4R000
A3C122	281-0306-00			CAP,VAR,CER DI:3.3-20PF	52769	GKU 18000
A3C123	281-0909-00			CAP,FXD,CERAMIC:MLC;0.022UF,20%,50V	04222	SA105C223MAA
A3C124	281-0909-00			CAP,FXD,CERAMIC:MLC;0.022UF,20%,50V	04222	SA105C223MAA
A3C125	281-0759-00			CAP,FXD,CERAMIC:MLC;22PF,10%,100V	04222	SA102A220KAA

Component Number	Tektronix Part No.	Serial No.		Name & Description	Mfr. Code	Mfr. Part No.
		Effective	Dscont			
A3C126	281-0759-00			CAP,FXD,CERAMIC:MLC;22PF,10%,100V	04222	SA102A220KAA
A3C128	281-0909-00			CAP,FXD,CERAMIC:MLC;0.022UF,20%,50V	04222	SA105C223MAA
A3C130	281-0909-00			CAP,FXD,CERAMIC:MLC;0.022UF,20%,50V (TAS475 ONLY)	04222	SA105C223MAA
A3C201	281-0909-00			CAP,FXD,CERAMIC:MLC;0.022UF,20%,50V (TAS475 ONLY)	04222	SA105C223MAA
A3C203	285-1460-00			CAP,FXD,MTLZD:0.1UF,20%,250V,5MM LEAD SPAC	TK1913	MKS 2 0.1/250/2
A3C204	281-0909-00			CAP,FXD,CERAMIC:MLC;0.022UF,20%,50V	04222	SA105C223MAA
A3C205	285-1460-00			CAP,FXD,MTLZD:0.1UF,20%,250V,5MM LEAD SPAC	TK1913	MKS 2 0.1/250/2
A3C206	281-0909-00			CAP,FXD,CERAMIC:MLC;0.022UF,20%,50V (TAS485 ONLY)	04222	SA105C223MAA
A3C207	285-1460-00			CAP,FXD,MTLZD:0.1UF,20%,250V,5MM LEAD SPAC	TK1913	MKS 2 0.1/250/2
A3C210	281-0909-00			CAP,FXD,CERAMIC:MLC;0.022UF,20%,50V,0.100 X	04222	SA105C223MAA
A3C211	285-1460-00			CAP,FXD,MTLZD:0.1UF,20%,250V,5MM LEAD SPAC	TK1913	MKS 2 0.1/250/2
A3C213	281-0064-00	B010100	B010370	CAP,VAR,PLASTIC:0.25-1.5PF,600V (TAS485 ONLY)	52769	ER-530-013
A3C214	281-0765-00			CAP,FXD,CER DI:100PF,5%,100V	04222	SA102A101JAA
A3C216	281-0537-00	B010432		CAP,FXD,CER DI:0.68PF,20%,600V (TAS475 ONLY)	54583	DA12COG2HR68M
A3C216	281-0537-00			CAP,FXD,CER DI:0.68PF,20%,600V (TAS485 ONLY)	54583	DA12COG2HR68M
A3C218	281-0064-00	B010100	B010431	CAP,VAR,PLASTIC:0.25-1.5PF,600V (TAS475 ONLY)	52769	ER-530-013
A3C219	285-1460-00			CAP,FXD,MTLZD:0.1UF,20%,250V,5MM LEAD SPAC	TK1913	MKS 2 0.1/250/2
A3C221	283-0341-01			CAP,FXD,CER DI:0.047UF,10%,100V	04222	SR301C473KAAAP1
A3C222	281-0810-00			CAP,FXD,CERAMIC:MLC;5.6PF,+/-0.5PF,100V (TAS475 ONLY)	04222	SA102A5R6DAA
A3C222	281-0909-00			CAP,FXD,CERAMIC:MLC;0.022UF,20%,50V (TAS485 ONLY)	04222	SA105C223MAA
A3C223	281-0537-00			CAP,FXD,CER DI:0.68PF,20%,600V (TAS475 ONLY)	54583	DA12COG2HR68M
A3C226	281-0756-00			CAP,FXD,CERAMIC:MLC;2.2PF,+/-0.5PF,200V (TAS485 ONLY)	04222	SA102A2R2DAA
A3C227	281-0893-00			CAP,FXD,CERAMIC:MLC;4.7PF,+/-0.5PF,100V (TAS485 ONLY)	04222	SA102A4R7DAA
A3C256	281-0819-00			CAP,FXD,CERAMIC:MLC;33 PF,5%,50V (TAS485 ONLY)	04222	SA102A330JAA
A3C258	281-0537-00			CAP,FXD,CER DI:0.68PF,20%,600V (TAS485 ONLY)	54583	DA12COG2HR68M
A3C301	281-0771-00			CAP,FXD,CER DI:2200PF,20%,200V	04222	SA102C222MAA
A3C302	285-1460-00			CAP,FXD,MTLZD:0.1UF,20%,250V,5MM LEAD SPAC	TK1913	MKS 2 0.1/250/2
A3C303	281-0909-00			CAP,FXD,CERAMIC:MLC;0.022UF,20%,50V	04222	SA105C223MAA
A3C304	285-1460-00			CAP,FXD,MTLZD:0.1UF,20%,250V,5MM LEAD SPAC	TK1913	MKS 2 0.1/250/2
A3C305	285-1460-00			CAP,FXD,MTLZD:0.1UF,20%,250V,5MM LEAD SPAC	TK1913	MKS 2 0.1/250/2
A3C306	285-1460-00			CAP,FXD,MTLZD:0.1UF,20%,250V,5MM LEAD SPAC	TK1913	MKS 2 0.1/250/2
A3C308	281-0762-00			CAP,FXD,CER DI:27PF,20%,100V	04222	SA102A270MAA

Replaceable Electrical Parts List

Component Number	Tektronix Part No.	Serial No.		Name & Description	Mfr. Code	Mfr. Part No.
		Effective	Dscont			
A3C309	281-0903-00			CAP,FXD,CER DI:3.9PF,100V	04222	SA102A3R9DAA
A3C310	285-1460-00			CAP,FXD,MTLZD:0.1UF,20%,250V	TK1913	MKS 2 0.1/250/2
A3C311	285-1184-00			CAP,FXD,MTLZD:0.01 UF,20%,4000V	24165	430P591
A3C312	285-1040-00			CAP,FXD,PLASTIC:1200PF,10%,4000V	84411	TEK-134-122940
A3C313	281-0771-00			CAP,FXD,CER DI:2200PF,20%,200V	04222	SA102C222MAA
A3C314	283-0279-00			CAP,FXD,CER DI:0.001UF,20%,3000V	18796	DHR12Y5S102M3KV
A3C315	285-1184-00			CAP,FXD,MTLZD:0.01 UF,20%,4000V	24165	430P591
A3C316	285-1040-00			CAP,FXD,PLASTIC:1200PF,10%,4000V	84411	TEK-134-122940
A3C317	281-0903-00			CAP,FXD,CER DI:3.9PF,100V	04222	SA102A3R9DAA
A3C319	281-0909-00			CAP,FXD,CERAMIC:MLC;0.022UF,20%,50V	04222	SA105C223MAA
A3C320	290-0776-01			CAP,FXD,ELCTLT:22UF,20%,10WVDC	55680	UVX1A220MAA1TD
A3C321	285-1460-00			CAP,FXD,MTLZD:0.1UF,20%,250V	TK1913	MKS 2 0.1/250/2
A3C322	283-0203-00			CAP,FXD,CER DI:0.47UF,20%,50V	04222	SR305C474MAA
A3C323	283-0203-00			CAP,FXD,CER DI:0.47UF,20%,50V	04222	SR305C474MAA
A3C324	285-1460-00			CAP,FXD,MTLZD:0.1UF,20%,250V (TAS485 ONLY)	TK1913	MKS 2 0.1/250/2
A3CR100	152-0066-00			DIODE,RECT:,400V,1A	05828	GP10G-020
A3CR101	152-0066-00			DIODE,RECT:,400V,1A	05828	GP10G-020
A3CR102	152-0066-00			DIODE,RECT:,400V,1A	05828	GP10G-020
A3CR201	152-0141-02			DIODE,SIG:,ULTRA FAST;40V,150MA,4NS,2PF	27014	FDH9427
A3CR202	152-0141-02			DIODE,SIG:,ULTRA FAST;40V,150MA,4NS,2PF	27014	FDH9427
A3CR301	152-0141-02			DIODE,SIG:,ULTRA FAST;40V,150MA,4NS,2PF	27014	FDH9427
A3CR302	152-0400-00			DIODE,RECT:,FAST RCVRV;400V,1A,200NS	14552	MB2501
A3CR303	152-0400-00			DIODE,RECT:,FAST RCVRV;400V,1A,200NS	14552	MB2501
A3CR304	152-0400-00			DIODE,RECT:,FAST RCVRV;400V,1A,200NS	14552	MB2501
A3CR305	152-0141-02			DIODE,SIG:,ULTRA FAST;40V,150MA,4NS,2PF	27014	FDH9427
A3CR306	152-0400-00			DIODE,RECT:,FAST RCVRV;400V,1A,200NS	14552	MB2501
A3CR307	152-0141-02			DIODE,SIG:,ULTRA FAST;40V,150MA,4NS,2PF	27014	FDH9427
A3CR308	152-0141-02			DIODE,SIG:,ULTRA FAST;40V,150MA,4NS,2PF	27014	FDH9427
A3DS301	150-0035-00			LAMP,GLOW:90V MAX,0.3MA,AID-T,WIRE LD	TK0213	JH005/3011JA
A3DS302	150-0035-00			LAMP,GLOW:90V MAX,0.3MA,AID-T,WIRE LD	TK0213	JH005/3011JA
A3E103	276-0752-00			CORE,EM:FERRITE TELEQ (TAS485 ONLY)	TK1442	BP53-BH3.5X10X4
A3J69	131-5419-00			CONN,HDR:PCB,;MALE,STR,1 X 2,0.1 CT	00779	644486-2
A3J70	131-5349-00			CONN,HDR:PCB,;MALE,RTANG,1 X 13,0.156 CTR	00779	1-640387-3
A3J71	131-5350-00			CONN,HDR PWR:PCB;MALE,RTANG,1 X 2	00779	640387-2
A3J72	131-0589-00			TERMINAL,PIN:PRESSFIT/PCB,;MALE,STR (QTY 4)	22526	48283-087
A3J73	131-0589-00			TERMINAL,PIN:PRESSFIT/PCB,;MALE,STR (QTY 5)	22526	48283-087
A3J74	131-0589-00			TERMINAL,PIN:PRESSFIT/PCB,;MALE,STR (QTY 3)	22526	48283-087
A3J75	131-0589-00			TERMINAL,PIN:PRESSFIT/PCB,;MALE,STR (QTY 3, TAS475 ONLY)	22526	48283-087

Component Number	Tektronix Part No.	Serial No.		Name & Description	Mfr. Code	Mfr. Part No.
		Effective	Dscont			
A3J77	131-2427-00			TERM,QIK DISC.:PCB,;MALE TAB,0.250 X 0.032 (TAS485 ONLY)	00779	62409-1
A3J80	131-5348-00			CONN,HDR:PCB,;MALE,RTANG,1 X 2,0.1 CTR	00779	103672-1
A3L101	120-1906-00			TRANSFORMER,RF:COIL,RF,TAPPED INDUCTOR (TAS475 ONLY)	OJR03	120-1906-00
A3L101	108-1352-00			COIL,RF:FIXED,22UH,10% (TAS485 ONLY)	54583	SPT0305-220K
A3L102	120-1906-00			TRANSFORMER,RF:COIL,RF,TAPPED INDUCTOR (TAS475 ONLY)	OJR03	120-1906-00
A3L102	108-1352-00			COIL,RF:FIXED,22UH,10% (TAS485 ONLY)	54583	SPT0305-220K
A3L103	108-1352-00			COIL,RF:FIXED,22UH,10%	54583	SPT0305-220K
A3L104	108-0408-01			COIL,RF:FIXED,91NH ON FORM (TAS475 ONLY)	OJR03	108-0408-01
A3L105	108-0170-02			COIL,RF:FIXED,360NH	OJR03	108-0170-02
A3L106	108-0736-01			COIL,RF:FIXED,828NH	OJR03	108-0736-01
A3L107	108-0736-01			COIL,RF:FIXED,828NH	OJR03	108-0736-01
A3L108	108-0170-02			COIL,RF:FIXED,360NH	OJR03	108-0170-02
A3L109	108-0436-00			COIL,RF:FIXED,240UH ON FORM (TAS475 ONLY)	OJR03	OBD
A3L109	108-0260-00			COIL,RF:FIXED,98NH (TAS485 ONLY)	OJR03	ORDER BY DESC
A3L110	108-0408-01			COIL,RF:FIXED,91NH (TAS475 ONLY)	OJR03	108-0408-01
A3L111	108-1352-00			COIL,RF:FIXED,22UH,10% (TAS475 ONLY)	54583	SPT0305-220K
A3L111	108-0509-01			COIL,RF:FXD,2.45UH +/-10%,AXIAL LEAD (TAS485 ONLY)	OJR03	108-0509-01
A3L112	108-1352-00			COIL,RF:FIXED,22UH,10% (TAS475 ONLY)	54583	SPT0305-220K
A3L112	108-0509-01			COIL,RF:FXD,2.45UH +/-10%,AXIAL LEAD (TAS485 ONLY)	OJR03	108-0509-01
A3L113	108-1352-00			COIL,RF:FIXED,22UH,10% (TAS475 ONLY)	54583	SPT0305-220K
A3L113	108-0620-00			COIL,RF:FIXED,90NH (TAS485 ONLY)	OJR03	108-0620-00
A3L114	108-0620-00			COIL,RF:FIXED,90NH (TAS485 ONLY)	OJR03	108-0620-00
A3L300	108-1352-00			COIL,RF:FIXED,22UH,10%	54583	SPT0305-220K
A3Q101	151-0411-00			TRANSISTOR,SIG:BIPOLAR,NPN;30V,400MA,1.2GHZ (TAS475 ONLY)	04713	2N5943
A3Q101	151-1025-03			TRANSISTOR,SIG:JFET,N-CH;6V,15MA,4.5MS,AMP (TAS485 ONLY)	17856	J304TA
A3Q102	151-0411-00			TRANSISTOR,SIG:BIPOLAR,NPN;30V,400MA,1.2GHZ (TAS475 ONLY)	04713	2N5943
A3Q102	151-0190-00			TRANSISTOR,SIG:BIPOLAR,NPN;40V,200MA (TAS485 ONLY)	04713	2N3904

Replaceable Electrical Parts List

Component Number	Tektronix Part No.	Serial No.		Name & Description	Mfr. Code	Mfr. Part No.
		Effective	Dscont			
A3Q201	151-0711-02			TRANSISTOR,SIG:BIPOLAR,NPN;25V,50MA,650MHZ	04713	MPSH10RLRP
A3Q202	151-0711-02			TRANSISTOR,SIG:BIPOLAR,NPN;25V,50MA,650MHZ	04713	MPSH10RLRP
A3Q204	151-0190-00			TRANSISTOR,SIG:BIPOLAR,NPN;40V,200MA (TAS475 ONLY)	04713	2N3904
A3Q204	151-0965-00			TRANSISTOR,SIG:BIPOLAR,NPN;10V,80MA,6.0GHZ (TAS485 ONLY)	04713	MPS571
A3Q205	151-0347-00			TRANSISTOR,SIG:BIPOLAR,NPN;160V,600MA	0JR04	2N5551
A3Q206	151-0347-00			TRANSISTOR,SIG:BIPOLAR,NPN;160V,600MA	0JR04	2N5551
A3Q208	151-0350-03			TRANSISTOR,SIG:BIPOLAR,PNP;150V,600MA	27014	S44295
A3Q209	151-0350-03			TRANSISTOR,SIG:BIPOLAR,PNP;150V,600MA	27014	S44295
A3Q210	151-0271-00			TRANSISTOR,SIG:BIPOLAR,PNP;15V,30MA,2.0GHZ	04713	MPSH69
A3Q210	151-0970-00			TRANSISTOR,SIG:BIPOLAR,PNP;10V,30MA,,4.5GHZ (TAS485 ONLY)	04713	MPS536RLRP
A3Q211	151-0271-00			TRANSISTOR,SIG:BIPOLAR,PNP;15V,30MA,2.0GHZ (TAS475 ONLY)	04713	MPSH69
A3Q211	151-0347-00			TRANSISTOR,SIG:BIPOLAR,NPN;160V,600MA (TAS485 ONLY)	0JR04	2N5551
A3Q212	151-0190-00			TRANSISTOR,SIG:BIPOLAR,NPN;40V,200M (TAS475 ONLY)	04713	2N3904
A3Q212	151-0350-03	B010100	B010370	TRANSISTOR,SIG:BIPOLAR,PNP;150V,600MA (TAS485 ONLY)	27014	S44295
A3Q213	151-0350-03			TRANSISTOR,SIG:BIPOLAR,PNP;150V,600MA (TAS485 ONLY)	27014	S44295
A3Q214	151-0347-00	B010100	B010370	TRANSISTOR,SIG:BIPOLAR,NPN;160V,600MA (TAS485 ONLY)	0JR04	2N5551
A3Q215	151-0711-02			TRANSISTOR,SIG:BIPOLAR,NPN;25V,50MA,650MHZ (TAS485 ONLY)	04713	MPSH10RLRP
A3Q216	151-0711-02			TRANSISTOR,SIG:BIPOLAR,NPN;25V,50MA,650MHZ (TAS485 ONLY)	04713	MPSH10RLRP
A3Q217	151-0965-00			TRANSISTOR,SIG:BIPOLAR,NPN;10V,80MA,6.0GHZ (TAS485 ONLY)	04713	MPS571
A3Q218	151-0970-00			TRANSISTOR,SIG:BIPOLAR,PNP;10V,30MA,,4.5GHZ (TAS485 ONLY)	04713	MPS536RLRP
A3Q301	151-0188-00			TRANSISTOR,SIG:BIPOLAR,PNP;40V,200MA	04713	2N3906
A3Q302	151-0188-00			TRANSISTOR,SIG:BIPOLAR,PNP;40V,200MA	04713	2N3906
A3Q303	151-0190-00			TRANSISTOR,SIG:BIPOLAR,NPN;40V,200MA	04713	2N3904
A3Q304	151-0190-00			TRANSISTOR,SIG:BIPOLAR,NPN;40V,200MA	04713	2N3904
A3Q307	151-0199-00			TRANSISTOR,SIG:BIPOLAR,PNP;12V,80MA,SWITCH	04713	MPS3640
A3Q308	151-0350-03			TRANSISTOR,SIG:BIPOLAR,PNP;150V,600MA	27014	S44295
A3Q360	151-0749-00			TRANSISTOR,SIG:BIPOLAR,PNP;400V,500MA	04713	MPSA94
A3Q361	151-0749-00			TRANSISTOR,SIG:BIPOLAR,PNP;400V,500MA	04713	MPSA94
A3R101	322-3001-00			RES,FXD:METAL FILM;10 OHM,1%,0.2W (TAS475 ONLY)	91637	CCF501G10R00F
A3R101	313-1100-00			RES,FXD,FILM:10 OHM,5%,0.2W (TAS485 ONLY)	91637	CCF50-2-10R00J

Replaceable Electrical Parts List

Component Number	Tektronix Part No.	Serial No.		Name & Description	Mfr. Code	Mfr. Part No.
		Effective	Dscont			
A3R102	322-3001-00			RES,FXD:METAL FILM;10 OHM,1%,0.2W (TAS475 ONLY)	91637	CCF501G10R00F
A3R102	322-3097-00			RES,FXD:METAL FILM;100 OHM,1%,0.2W (TAS485 ONLY)	91637	CCF501G100R0F
A3R103	313-1202-00			RES,FXD,FILM:2K OHM,5%,0.2W	91637	CCF50-2-20000J
A3R104	322-3217-00			RES,FXD,FILM:1.78K OHM,1%,0.2W (TAS475 ONLY)	91637	CCF501G17800F
A3R104	322-3226-00			RES,FXD:METAL FILM;2.21K OHM,1%,0.2W (TAS485 ONLY)	91637	CCF501G22100F
A3R105	313-1102-00			RES,FXD,FILM:1K OHM,5%,0.2W	91637	CCF50-2-10000J
A3R106	322-3085-00			RES,FXD:METAL FILM;75 OHM,1%,0.2W (TAS475 ONLY)	91637	CCF501G75R00F
A3R107	322-3085-00			RES,FXD:METAL FILM;75 OHM,1%,0.2W (TAS475 ONLY)	91637	CCF501G75R00F
A3R108	313-1470-00			RES,FXD,FILM:47 OHM,5%,0.2W (TAS475 ONLY)	91637	CCF50-2-47R00J
A3R109	313-1470-00			RES,FXD,FILM:47 OHM,5%,0.2W (TAS475 ONLY)	91637	CCF50-2-47R00J
A3R111	311-2234-00			RES,VAR,TRMR:CERMET;5K OHM,20%,0.5W	TK2073	GF06UT2 502 M L
A3R112	311-2230-00			RES,VAR,TRMR:CERMET;500 OHM,20%,0.5W (TAS475 ONLY)	TK2073	GF06UT2 501 M L
A3R112	311-2234-00			RES,VAR,TRMR:CERMET;5K OHM,20%,0.5W (TAS485 ONLY)	TK2073	GF06UT2 502 M L
A3R113	322-3085-00			RES,FXD:METAL FILM;75 OHM,1%,0.2W	91637	CCF501G75R00F
A3R114	322-3085-00			RES,FXD:METAL FILM;75 OHM,1%,0.2W	91637	CCF501G75R00F
A3R115	313-1202-00			RES,FXD,FILM:2K OHM,5%,0.2W (TAS475 ONLY)	91637	CCF50-2-20000J
A3R116	313-1103-00			RES,FXD,FILM:10K OHM,5%,0.2W	91637	CCF50-2-10001J
A3R117	313-1103-00			RES,FXD,FILM:10K OHM,5%,0.2W	91637	CCF50-2-10001J
A3R120	313-1103-00			RES,FXD,FILM:10K OHM,5%,0.2W	91637	CCF50-2-10001J
A3R121	313-1103-00			RES,FXD,FILM:10K OHM,5%,0.2W	91637	CCF50-2-10001J
A3R122	307-1606-00			RES,FXD FILM:METAL,FILM,221 OHM,1% (TAS475 ONLY)	56845	CPF-3-F2210F-T/
A3R123	307-1606-00			RES,FXD FILM:METAL,FILM,221 OHM,1% (TAS475 ONLY)	56845	CPF-3-F2210F-T/
A3R124	308-0075-00			RES,FXD,WW:100 OHM,5%,3W (TAS475 ONLY)	91637	CW2B-100R0J-T/R
A3R125	322-3068-00			RES,FXD:METAL FILM;49.9 OHM,1%,0.2W (TAS475 ONLY)	91637	CCF501G49R90F
A3R126	131-1817-01			BUS,CONDUCTOR:22 AWG,2.0 TO 2.125 SPACING (TAS475 ONLY)	TK1492	ORDER BY DESC
A3R127	322-3097-00			RES,FXD:METAL FILM;100 OHM,1%,0.2W (TAS475 ONLY)	91637	CCF501G100R0F
A3R128	322-3085-00			RES,FXD:METAL FILM;75 OHM,1%,0.2W (TAS475 ONLY)	91637	CCF501G75R00F
A3R129	322-3001-00			RES,FXD:METAL FILM;10 OHM,1%,0.2W	91637	CCF501G10R00F

Replaceable Electrical Parts List

Component Number	Tektronix Part No.	Serial No.		Name & Description	Mfr. Code	Mfr. Part No.
		Effective	Dscont			
A3R130	322-3068-00			RES,FXD:METAL FILM;49.9 OHM,1%,0.2W (TAS475 ONLY)	91637	CCF501G49R90F
A3R131	131-1817-01			BUS,CONDUCTOR:22 AWG,2.0 TO 2.125 SPACING (TAS475 ONLY)	TK1492	ORDER BY DESC
A3R132	322-3097-00			RES,FXD:METAL FILM;100 OHM,1%,0.2W (TAS475 ONLY)	91637	CCF501G100R0F
A3R133	322-3085-00			RES,FXD:METAL FILM;75 OHM,1%,0.2W (TAS475 ONLY)	91637	CCF501G75R00F
A3R134	322-3062-00			RES,FXD,FILM:43.2 OHM,1%,0.2W (TAS475 ONLY)	57668	RB20FXE43E2
A3R135	322-3001-00			RES,FXD:METAL FILM;10 OHM,1%,0.2W	91637	CCF501G10R00F
A3R136	313-1200-00			RES,FXD,FILM:20 OHM,5%,0.2W (TAS485 ONLY)	91637	CCF50-2-20R00J
A3R137	313-1200-00			RES,FXD,FILM:20 OHM,5%,0.2W (TAS485 ONLY)	91637	CCF50-2-20R00J
A3R138	313-1027-00			RES,FXD,FILM:2.7 OHM,5%,0.2W	91637	CT3-2R700J
A3R139	322-3039-00			RES,FXD,FILM:24.9 OHM,1%,0.2W (TAS475 ONLY)	91637	CCF50-2-G24R90F
A3R140	311-2230-00			RES,VAR,TRMR:CERMET;500 OHM,20%,0.5W (TAS475 ONLY)	TK2073	GF06UT2 501 M L
A3R140	311-2229-00			RES,VAR,NONWW:TRMR,250 OHM,20%,0.5W (TAS485 ONLY)	TK2073	GF06UT2 251 M L
A3R141	311-2231-00			RES,VAR,TRMR:CERMET;1K OHM,20%,0.5W (TAS475 ONLY)	TK2073	GF06UT2 102 M L
A3R142	313-1027-00			RES,FXD,FILM:2.7 OHM,5%,0.2W (TAS475 ONLY)	91637	CT3-2R700J
A3R142	311-2229-00			RES,VAR,NONWW:TRMR,250 OHM,20%,0.5W (TAS485 ONLY)	TK2073	GF06UT2 251 M L
A3R144	322-3001-00			RES,FXD:METAL FILM;10 OHM,1%,0.2W (TAS475 ONLY)	91637	CCF501G10R00F
A3R145	322-3001-00			RES,FXD:METAL FILM;10 OHM,1%,0.2W (TAS475 ONLY)	91637	CCF501G10R00F
A3R146	313-1027-00			RES,FXD,FILM:2.7 OHM,5%,0.2W (TAS485 ONLY)	91637	CT3-2R700J
A3R147	322-3085-00			RES,FXD:METAL FILM;75 OHM,1%,0.2W (TAS475 ONLY)	91637	CCF501G75R00F
A3R148	322-3085-00			RES,FXD:METAL FILM;75 OHM,1%,0.2W (TAS475 ONLY)	91637	CCF501G75R00F
A3R149	313-1027-00			RES,FXD,FILM:2.7 OHM,5%,0.2W (TAS475 ONLY)	91637	CT3-2R700J
A3R150	313-1027-00			RES,FXD,FILM:2.7 OHM,5%,0.2W (TAS475 ONLY)	91637	CT3-2R700J
A3R151	322-3226-00			RES,FXD:METAL FILM;2.21K OHM,1%,0.2W (TAS475 ONLY)	91637	CCF501G22100F
A3R152	313-1202-00			RES,FXD,FILM:2K OHM,5%,0.2W (TAS475 ONLY)	91637	CCF50-2-20000J
A3R153	322-3039-00			RES,FXD,FILM:24.9 OHM,1%,0.2W (TAS475 ONLY)	91637	CCF50-2-G24R90F

Component Number	Tektronix Part No.	Serial No.		Name & Description	Mfr. Code	Mfr. Part No.
		Effective	Dscont			
A3R154	311-2231-00			RES,VAR,TRMR:CERMET;1K OHM,20%,0.5W (TAS475 ONLY)	TK2073	GF06UT2 102 M L
A3R154	311-2234-00			RES,VAR,TRMR:CERMET;5K OHM,20%,0.5W (TAS485 ONLY)	TK2073	GF06UT2 502 M L
A3R155	313-1027-00			RES,FXD,FILM:2.7 OHM,5%,0.2W (TAS475 ONLY)	91637	CT3-2R700J
A3R156	313-1027-00			RES,FXD,FILM:2.7 OHM,5%,0.2W	91637	CT3-2R700J
A3R157	313-1027-00			RES,FXD,FILM:2.7 OHM,5%,0.2W	91637	CT3-2R700J
A3R201	322-3402-00			RES,FXD:METAL FILM;150K OHM,1%,0.2W	91637	CCF50G15002F
A3R202	322-3402-00			RES,FXD:METAL FILM;150K OHM,1%,0.2W	91637	CCF50G15002F
A3R205	313-1682-00			RES,FXD,FILM:6.8K OHM,5%,0.2W	91637	CCF50-2-68000J
A3R206	313-1682-00			RES,FXD,FILM:6.8K OHM,5%,0.2W	91637	CCF50-2-68000J
A3R207	313-1470-00			RES,FXD,FILM:47 OHM,5%,0.2W	91637	CCF50-2-47R00J
A3R210	313-1511-00			RES,FXD,FILM:510 OHM,5%,0.2W (TAS475 ONLY)	91637	CCF50-2-510ROJ
A3R210	313-1361-00			RES,FXD,FILM:360 OHM,5%,0.2W (TAS485 ONLY)	91637	CCF50-2-360R0J
A3R211	313-1511-00			RES,FXD,FILM:510 OHM,5%,0.2W (TAS475 ONLY)	91637	CCF50-2-510ROJ
A3R211	313-1361-00			RES,FXD,FILM:360 OHM,5%,0.2W (TAS485 ONLY)	91637	CCF50-2-360R0J
A3R212	313-1100-00			RES,FXD,FILM:10 OHM,5%,0.2W	91637	CCF50-2-10R00J
A3R213	313-1100-00			RES,FXD,FILM:10 OHM,5%,0.2W (TAS475 ONLY)	91637	CCF50-2-10R00J
A3R214	313-1470-00			RES,FXD,FILM:47 OHM,5%,0.2W	91637	CCF50-2-47R00J
A3R215	313-1272-00			RES,FXD,FILM:2.7K OHM,5%,0.2W	91637	CCF50-2-27000J
A3R216	313-1272-00			RES,FXD,FILM:2.7K OHM,5%,0.2W	91637	CCF50-2-27000J
A3R217	322-3243-00			RES,FXD:METAL FILM;3.32K OHM,1%,0.2W	91637	CCF50-1-G33200F
A3R218	322-3158-00			RES,FXD,FILM:432 OHM,1%,0.2W	57668	CRB2D FXE 432
A3R219	322-3287-00			RES,FXD,FILM:9.53K OHM,1%,0.2W	91637	CCF50G95300F
A3R220	322-3371-00			RES,FXD,FILM:71.5K OHM,1%,0.2W	91637	CCF50G71501F
A3R221	322-3243-00			RES,FXD:METAL FILM;3.32K OHM,1%,0.2W	91637	CCF50-1-G33200F
A3R222	322-3097-00			RES,FXD:METAL FILM;100 OHM,1%,0.2W (TAS475 ONLY)	91637	CCF501G100R0F
A3R223	322-3097-00			RES,FXD:METAL FILM;100 OHM,1%,0.2W (TAS475 ONLY)	91637	CCF501G100R0F
A3R224	322-3243-00			RES,FXD:METAL FILM;3.32K OHM,1%,0.2W (TAS475 ONLY)	91637	CCF50-1-G33200F
A3R224	322-3226-00			RES,FXD:METAL FILM;2.21K OHM,1%,0.2W (TAS485 ONLY)	91637	CCF501G22100F
A3R225	322-3485-00			RES,FXD,FILM:5.0K OHM,1%,0.2W	91637	CCF501G50000F
A3R226	322-3085-00			RES,FXD:METAL FILM;75 OHM,1%,0.2W	91637	CCF501G75R00F
A3R227	322-3085-00			RES,FXD:METAL FILM;75 OHM,1%,0.2W	91637	CCF501G75R00F
A3R228	322-3485-00			RES,FXD,FILM:5.0K OHM,1%,0.2W	91637	CCF501G50000F
A3R229	313-1511-00			RES,FXD,FILM:510 OHM,5%,0.2W	91637	CCF50-2-510ROJ

Replaceable Electrical Parts List

Component Number	Tektronix Part No.	Serial No.		Name & Description	Mfr. Code	Mfr. Part No.
		Effective	Dscont			
A3R230	322-3243-00			RES,FXD:METAL FILM;3.32K OHM,1%,0.2W (TAS475 ONLY)	91637	CCF50-1-G33200F
A3R230	322-3226-00			RES,FXD:METAL FILM;2.21K OHM,1%,0.2W (TAS485 ONLY)	91637	CCF501G22100F
A3R231	322-3085-00			RES,FXD:METAL FILM;75 OHM,1%,0.2W (TAS475 ONLY)	91637	CCF501G75R00F
A3R231	322-3105-00			RES,FXD:METAL FILM;121 OHM,1%,0.2W (TAS485 ONLY)	91637	CCF501G121ROF
A3R232	322-3085-00			RES,FXD:METAL FILM;75 OHM,1%,0.2W (TAS475 ONLY)	91637	CCF501G75R00F
A3R232	322-3105-00			RES,FXD:METAL FILM;121 OHM,1%,0.2W (TAS485 ONLY)	91637	CCF501G121ROF
A3R233	322-3243-00			RES,FXD:METAL FILM;3.32K OHM,1%,0.2W (TAS475 ONLY)	91637	CCF50-1-G33200F
A3R234	322-3243-00			RES,FXD:METAL FILM;3.32K OHM,1%,0.2W (TAS475 ONLY)	91637	CCF50-1-G33200F
A3R234	322-3226-00			RES,FXD:METAL FILM;2.21K OHM,1%,0.2W (TAS485 ONLY)	91637	CCF501G22100F
A3R235	322-3485-00			RES,FXD,FILM:5.0K OHM,1%,0.2W	91637	CCF501G50000F
A3R236	322-3485-00			RES,FXD,FILM:5.0K OHM,1%,0.2W	91637	CCF501G50000F
A3R237	322-3485-00			RES,FXD,FILM:5.0K OHM,1%,0.2W	91637	CCF501G50000F
A3R238	322-3485-00			RES,FXD,FILM:5.0K OHM,1%,0.2W	91637	CCF501G50000F
A3R239	322-3243-00			RES,FXD:METAL FILM;3.32K OHM,1%,0.2W (TAS475 ONLY)	91637	CCF50-1-G33200F
A3R239	322-3226-00			RES,FXD:METAL FILM;2.21K OHM,1%,0.2W (TAS485 ONLY)	91637	CCF501G22100F
A3R240	322-3243-00			RES,FXD:METAL FILM;3.32K OHM,1%,0.2W (TAS475 ONLY)	91637	CCF50-1-G33200F
A3R240	322-3226-00			RES,FXD:METAL FILM;2.21K OHM,1%,0.2W (TAS485 ONLY)	91637	CCF501G22100F
A3R241	322-3243-00			RES,FXD:METAL FILM;3.32K OHM,1%,0.2W (TAS475 ONLY)	91637	CCF50-1-G33200F
A3R241	322-3226-00			RES,FXD:METAL FILM;2.21K OHM,1%,0.2W (TAS485 ONLY)	91637	CCF501G22100F
A3R242	322-3243-00			RES,FXD:METAL FILM;3.32K OHM,1%,0.2W (TAS475 ONLY)	91637	CCF50-1-G33200F
A3R242	322-3226-00			RES,FXD:METAL FILM;2.21K OHM,1%,0.2W (TAS485 ONLY)	91637	CCF501G22100F
A3R244	313-1027-00			RES,FXD,FILM:2.7 OHM,5%,0.2W	91637	CT3-2R700J
A3R245	322-3243-00			RES,FXD:METAL FILM;3.32K OHM,1%,0.2W	91637	CCF50-1-G33200F
A3R246	313-1027-00			RES,FXD,FILM:2.7 OHM,5%,0.2W	91637	CT3-2R700J
A3R255	313-1027-00			RES,FXD,FILM:2.7 OHM,5%,0.2W	91637	CT3-2R700J
A3R256	313-1682-00			RES,FXD,FILM:6.8K OHM,5%,0.2W (TAS475 ONLY)	91637	CCF50-2-68000J
A3R257	313-1333-00			RES,FXD,FILM:33K OHM,5%,0.2W (TAS475 ONLY)	91637	CCF50-2-33001J
A3R257	313-1101-00			RES,FXD,FILM:100 OHM,5%,0.2W (TAS485 ONLY)	91637	CCF50-2-100R0J

Component Number	Tektronix Part No.	Serial No.		Name & Description	Mfr. Code	Mfr. Part No.
		Effective	Dscont			
A3R258	322-3085-00			RES,FXD:METAL FILM;75 OHM,1%,0.2W (TAS475 ONLY)	91637	CCF501G75R00F
A3R258	313-1101-00			RES,FXD,FILM:100 OHM,5%,0.2W (TAS485 ONLY)	91637	CCF50-2-100R0J
A3R259	322-3085-00			RES,FXD:METAL FILM;75 OHM,1%,0.2W (TAS475 ONLY)	91637	CCF501G75R00F
A3R259	313-1120-00			RES,FXD,FILM:12 OHM,5%,0.2W (TAS485 ONLY)	91637	CCF50-2-12R00J
A3R260	315-0475-00			RES,FXD,FILM:4.7M OHM,5%,0.25W (TAS475 ONLY)	TK1727	SFR25 2322-181-
A3R260	313-1100-00			RES,FXD,FILM:10 OHM,5%,0.2W (TAS485 ONLY)	91637	CCF50-2-10R00J
A3R262	313-1302-00			RES,FXD,FILM:3K OHM,5%,0.2W (TAS485 ONLY)	91637	CCF50-2-30000J
A3R263	313-1302-00			RES,FXD,FILM:3K OHM,5%,0.2W (TAS485 ONLY)	91637	CCF50-2-30000J
A3R264	322-3158-00			RES,FXD,FILM:432 OHM,1%,0.2W (TAS485 ONLY)	57668	CRB2D FXE 432
A3R265	322-3226-00			RES,FXD:METAL FILM;2.21K OHM,1%,0.2W (TAS485 ONLY)	91637	CCF501G22100F
A3R266	313-1331-00			RES,FXD,FILM:330 OHM,5%,0.2W (TAS485 ONLY)	91637	CCF50-2-330R0J
A3R267	322-3085-00			RES,FXD:METAL FILM;75 OHM,1%,0.2W (TAS485 ONLY)	91637	CCF501G75R00F
A3R268	322-3085-00			RES,FXD:METAL FILM;75 OHM,1%,0.2W (TAS485 ONLY)	91637	CCF501G75R00F
A3R301	313-1681-00			RES,FXD,FILM:680 OHM,5%,0.2W	91637	CCF50-2-680R0J
A3R303	315-0201-02			RES,FXD,CMPSN:200 OHM,5%,0.25W	50139	CB2015
A3R304	313-1203-00			RES,FXD,FILM:20K OHM,5%,0.2W (TAS475 ONLY)	91637	CCF50-2-20001J
A3R304	313-1203-00	B010100	B010230	RES,FXD,FILM:20K OHM,5%,0.2W (TAS485 ONLY)	91637	CCF50-2-20001J
A3R304	322-3300-00	B010231		RES,FXD:METAL FILM;13 OHM,1%,0.2W (TAS485 ONLY)	91637	CCF501G13R00F
A3R305	315-0511-02			RES,FXD,CMPSN:510 OHM,.25W,5%	50139	CB5115 ALLEN BR
A3R306	313-1243-00			RES,FXD,FILM:24K OHM,5%,0.2W	91637	R20J24K
A3R307	315-0511-02			RES,FXD,CMPSN:510 OHM,.25W,5%	50139	CB5115 ALLEN BR
A3R308	313-1333-00			RES,FXD,FILM:33K OHM,5%,0.2W	91637	CCF50-2-33001J
A3R309	313-1104-00			RES,FXD,FILM:100K OHM,5%,0.2W (TAS475 ONLY)	91637	CCF50-2-10002J
A3R309	313-1124-00			RES,FXD,FILM:120K OHM,5%,0.2W (TAS485 ONLY)	91637	CCF50-2-12002J
A3R310	313-1102-00			RES,FXD,FILM:1K OHM,5%,0.2W	91637	CCF50-2-10000J
A3R311	313-1102-00			RES,FXD,FILM:1K OHM,5%,0.2W	91637	CCF50-2-10000J
A3R312	313-1223-00			RES,FXD,FILM:22K,OHM,5%,0.2W	91637	CCF50-2-22001J
A3R313	313-1223-00			RES,FXD,FILM:22K,OHM,5%,0.2W	91637	CCF50-2-22001J
A3R314	313-1203-00			RES,FXD,FILM:20K OHM,5%,0.2W	91637	CCF50-2-20001J
A3R315	313-1203-00			RES,FXD,FILM:20K OHM,5%,0.2W	91637	CCF50-2-20001J

Replaceable Electrical Parts List

Component Number	Tektronix Part No.	Serial No.		Name & Description	Mfr. Code	Mfr. Part No.
		Effective	Dscont			
A3R316	322-3085-00			RES,FXD:METAL FILM;75 OHM,1%,0.2W	91637	CCF501G75R00F
A3R317	322-3402-00			RES,FXD:METAL FILM;150K OHM,1%,0.2W	91637	CCF50G15002F
A3R318	313-1681-00			RES,FXD,FILM:680 OHM,5%,0.2W	91637	CCF50-2-680ROJ
A3R321	311-2237-00			RES,VAR,TRMR:CERMET;25K OHM,20%,0.5W	TK2073	GF06UT2 253 M L
A3R322	311-2239-00			RES,VAR,TRMR:CERMET;100K OHM,20%,0.5W	TK2073	GF06UT2 104 M L
A3R323	311-2239-00			RES,VAR,TRMR:CERMET;100K OHM,20%,0.5W	TK2073	GF06UT2 104 M L
A3R324	313-1682-00			RES,FXD,FILM:6.8K OHM,5%,0.2W	91637	CCF50-2-68000J
A3R325	315-0472-03			RES,FXD,CMPSN:4.7K OHM,5%,0.25W	50139	CB4725
A3R326	315-0103-03			RES,FXD,CMPSN:10K OHM,5%,0.25W	50139	CB1035
A3R329	315-0625-00			RES,FXD,FILM:6.2M OHM,5%,0.25W	TK1727	SFR25 2322-181-
A3R330	313-1683-00			RES,FXD,FILM:68K OHM,5%,0.2W	91637	CCF50-2-6800IJ
A3R331	313-1823-00			RES,FXD,FILM:82K OHM,5%,0.2W	91637	CCF50-2-82001J
A3R332	313-1392-00			RES,FXD,FILM:3.9K OHM,5%,0.2W (TAS475 ONLY)	91637	CCF50-2-39000J
A3R333	313-1392-00			RES,FXD,FILM:3.9K OHM,5%,0.2W	91637	CCF50-2-39000J
A3R350	322-3306-00			RES,FXD:METAL FILM;15K OHM,1%,0.2W	91637	CCF50-2-G1502F
A3R351	315-0201-02			RES,FXD,CMPSN:200 OHM,5%,0.25W	50139	CB2015
A3R352	313-1027-00			RES,FXD,FILM:2.7 OHM,5%,0.2W	91637	CT3-2R700J
A3R353	313-1027-00			RES,FXD,FILM:2.7 OHM,5%,0.2W	91637	CT3-2R700J
A3R360	301-0754-01			RES,FXD,CMPSN:750K OHM,5%,0.5W	50139	EB7545
A3R361	301-0394-00			RES,FXD,FILM:390K OHM,5%,0.5W	19701	5053CX 390K0J
A3R362	301-0434-00			RES,FXD,FILM:430K OHM,5%,0.5W	19701	5053CX430K0J
A3R363	301-0434-00			RES,FXD,FILM:430K OHM,5%,0.5W	19701	5053CX430K0J
A3R364	322-0481-00			RES,FXD,FILM:1M OHM,1%,0.25W	91637	CMF6042G10003F
A3R365	322-0481-00			RES,FXD,FILM:1M OHM,1%,0.25W	91637	CMF6042G10003F
A3R366	322-3322-00			RES,FXD:METAL FILM;22.1K OHM,1%,0.2W	91637	CCF501G22101F
A3R367	301-0434-00			RES,FXD,FILM:430K OHM,5%,0.5W	19701	5053CX430K0J
A3R368	321-0385-00			RES,FXD,FILM:100K OHM,1%,0.125W	19701	5043ED100K0F
A3R369	301-0434-00			RES,FXD,FILM:430K OHM,5%,0.5W	19701	5053CX430K0J
A3R370	131-0566-00			BUS,CONDUCTOR:DUMMY RES,0.094 OD X 0.225L	24546	OMA0207
A3R371	322-3097-00			RES,FXD:METAL FILM;100 OHM,1%,0.2W	91637	CCF501G100R0F
A3R373	313-1027-00			RES,FXD,FILM:2.7 OHM,5%,0.2W (TAS485 ONLY)	91637	CT3-2R700J
A3U101	155-0322-00			MICROCKT,LINEAR:VERTICAL OUTPUT AMPLIFIER (TAS475 ONLY)	80009	155032200
A3U101	165-2393-00			MICROCKT,LINEAR:VERTICAL OUTPUT (TAS485 ONLY)	80009	165239300
A3U102	156-0158-00			IC,LINEAR:BIPOLAR,OP-AMP;DUAL	01295	MC1458P
A3U201	156-0158-00			IC,LINEAR:BIPOLAR,OP-AMP;DUAL	01295	MC1458P
A3VR201	152-0055-00			DIODE,ZENER::;11V,5%,0.4W	04713	SZG35009K1 1N96
A3VR360	152-0470-00			DIODE,ZENER::;200V,5%,0.4W	04713	1N992BRL
A3VR361	152-0470-00			DIODE,ZENER::;200V,5%,0.4W	04713	1N992BRL

Replaceable Electrical Parts List

Component Number	Tektronix Part No.	Serial No.		Name & Description	Mfr. Code	Mfr. Part No.
		Effective	Dscont			
A3W66	174-2602-00			CA ASSY,SP:FLAT FLEX,;FLX,23,26 AWG,6.5 L	TK2469	174-2602-00
A3W75	196-3391-00			LEAD,ELECTRICAL:VERTICAL DEFLECTION, WHITE (TAS485 ONLY)	0J7N9	196-3391-00
A3W76	196-3391-00			LEAD,ELECTRICAL:VERTICAL DEFLECTION, WHITE (TAS485 ONLY)	0J7N9	196-3391-00
A3W100	131-0566-00			BUS,CONDUCTOR:DUMMY RES,0.094 OD X 0.225L (TAS475 ONLY)	24546	OMA0207
A3W300	131-0566-00			BUS,CONDUCTOR:DUMMY RES,0.094 OD X 0.225L (TAS475 ONLY)	24546	OMA0207

Replaceable Electrical Parts List

Component Number	Tektronix Part No.	Serial No.		Name & Description	Mfr. Code	Mfr. Part No.
		Effective	Dscont			
A4	671-2220-00			CIRCUIT BD ASSY:FRONT PANEL	80009	671222000
A4C101	283-5004-00			CAP,FXD,CERAMIC:MLC;0.1UF,10%,25V,X7R,1206	04222	12063C104KAT3A
A4C121	283-5004-00			CAP,FXD,CERAMIC:MLC;0.1UF,10%,25V,X7R,1206	04222	12063C104KAT3A
A4C122	283-5004-00			CAP,FXD,CERAMIC:MLC;0.1UF,10%,25V,X7R,1206	04222	12063C104KAT3A
A4C131	290-5034-01			CAP,FXD,ALUM::;33UF,20%,10V,5.7MM(0.224)	1W344	MVK10VC33RME60T
A4C132	290-5034-01			CAP,FXD,ALUM::;33UF,20%,10V,5.7MM(0.224)	1W344	MVK10VC33RME60T
A4C140	283-5201-00			CAP,FXD,CERAMIC:MLC;33PF,5%,100V,NPO,1206	04222	12061A330JAT1A
A4C141	283-5201-00			CAP,FXD,CERAMIC:MLC;33PF,5%,100V,NPO,1206	04222	12061A330JAT1A
A4C202	283-5004-00			CAP,FXD,CERAMIC:MLC;0.1UF,10%,25V,X7R,1206	04222	12063C104KAT3A
A4C304	283-5004-00			CAP,FXD,CERAMIC:MLC;0.1UF,10%,25V,X7R,1206	04222	12063C104KAT3A
A4C305	283-5004-00			CAP,FXD,CERAMIC:MLC;0.1UF,10%,25V,X7R,1206	04222	12063C104KAT3A
A4C400	283-5004-00			CAP,FXD,CERAMIC:MLC;0.1UF,10%,25V,X7R,1206	04222	12063C104KAT3A
A4C401	283-5004-00			CAP,FXD,CERAMIC:MLC;0.1UF,10%,25V,X7R,1206	04222	12063C104KAT3A
A4C402	283-5004-00			CAP,FXD,CERAMIC:MLC;0.1UF,10%,25V,X7R,1206	04222	12063C104KAT3A
A4C403	283-5004-00			CAP,FXD,CERAMIC:MLC;0.1UF,10%,25V,X7R,1206	04222	12063C104KAT3A
A4C404	283-5004-00			CAP,FXD,CERAMIC:MLC;0.1UF,10%,25V,X7R,1206	04222	12063C104KAT3A
A4C405	283-5004-00			CAP,FXD,CERAMIC:MLC;0.1UF,10%,25V,X7R,1206	04222	12063C104KAT3A
A4C406	283-5004-00			CAP,FXD,CERAMIC:MLC;0.1UF,10%,25V,X7R,1206	04222	12063C104KAT3A
A4C407	283-5004-00			CAP,FXD,CERAMIC:MLC;0.1UF,10%,25V,X7R,1206	04222	12063C104KAT3A
A4C408	283-5004-00			CAP,FXD,CERAMIC:MLC;0.1UF,10%,25V,X7R,1206	04222	12063C104KAT3A
A4C409	283-5004-00			CAP,FXD,CERAMIC:MLC;0.1UF,10%,25V,X7R,1206	04222	12063C104KAT3A
A4C420	283-5004-00			CAP,FXD,CERAMIC:MLC;0.1UF,10%,25V,X7R,1206	04222	12063C104KAT3A
A4C421	283-5004-00			CAP,FXD,CERAMIC:MLC;0.1UF,10%,25V,X7R,1206	04222	12063C104KAT3A
A4C501	283-5203-00			CAP,FXD,CERAMIC:MLC;1000PF,10%,100V,X7R	04222	12061C102KAT1A
A4CR331	152-5018-00			DIODE,SIG:;ULTRA FAST;100V,0.74VF,4NS,2.0PF	27014	MMBD1203-HIGH
A4CR332	152-5018-00			DIODE,SIG:;ULTRA FAST;100V,0.74VF,4NS,2.0PF	27014	MMBD1203-HIGH
A4CR333	152-5018-00			DIODE,SIG:;ULTRA FAST;100V,0.74VF,4NS,2.0PF	27014	MMBD1203-HIGH
A4CR334	152-5018-00			DIODE,SIG:;ULTRA FAST;100V,0.74VF,4NS,2.0PF	27014	MMBD1203-HIGH
A4CR335	152-5018-00			DIODE,SIG:;ULTRA FAST;100V,0.74VF,4NS,2.0PF	27014	MMBD1203-HIGH
A4CR336	152-5018-00			DIODE,SIG:;ULTRA FAST;100V,0.74VF,4NS,2.0PF	27014	MMBD1203-HIGH
A4CR337	152-5018-00			DIODE,SIG:;ULTRA FAST;100V,0.74VF,4NS,2.0PF	27014	MMBD1203-HIGH
A4CR338	152-5018-00			DIODE,SIG:;ULTRA FAST;100V,0.74VF,4NS,2.0PF	27014	MMBD1203-HIGH
A4CR339	152-5018-00			DIODE,SIG:;ULTRA FAST;100V,0.74VF,4NS,2.0PF	27014	MMBD1203-HIGH
A4CR500	152-5018-00			DIODE,SIG:;ULTRA FAST;100V,0.74VF,4NS,2.0PF	27014	MMBD1203-HIGH
A4DS201	150-5008-00			DIODE,OPTO:;LED;GRN,569NM,4.2MCD AT 10MA	50434	HLMP-6505-T21
A4DS202	150-5008-00			DIODE,OPTO:;LED;GRN,569NM,4.2MCD AT 10MA	50434	HLMP-6505-T21
A4DS203	150-5008-00			DIODE,OPTO:;LED;GRN,569NM,4.2MCD AT 10MA	50434	HLMP-6505-T21
A4DS204	150-5008-00			DIODE,OPTO:;LED;GRN,569NM,4.2MCD AT 10MA	50434	HLMP-6505-T21
A4DS205	150-5008-00			DIODE,OPTO:;LED;GRN,569NM,4.2MCD AT 10MA	50434	HLMP-6505-T21
A4DS206	150-5008-00			DIODE,OPTO:;LED;GRN,569NM,4.2MCD AT 10MA	50434	HLMP-6505-T21
A4DS207	150-5008-00			DIODE,OPTO:;LED;GRN,569NM,4.2MCD AT 10MA	50434	HLMP-6505-T21

Component Number	Tektronix Part No.	Serial No.		Name & Description	Mfr. Code	Mfr. Part No.
		Effective	Dscont			
A4DS208	150-5008-00			DIODE,OPTO.;LED;GRN,569NM,4.2MCD AT 10MA	50434	HLMP-6505-T21
A4J30	131-5344-00			CONN,HDR:PCB.;MALE,STR,1 X 16,0.1 CTR	00779	1-103670-5
A4J35	131-5167-00			CONN,BOX PWR:PCB.;FEMALE,STR,1 X Y	27264	09-52-3022
A4J40	131-5158-00			CONN,HDR:PCB.;MALE,STR,1 X 10,0.1 CTR	00779	103669-9
A4J84	131-5157-00			CONN,HDR:PCB.;MALE,STR,1 X 5,0.1 CTR	00779	103669-4
A4R101	321-5030-00			RES,FXD:THICK FILM;10.0K OHM,1%,0.125W	50139	BCK1002FT
A4R102	321-5030-00			RES,FXD:THICK FILM;10.0K OHM,1%,0.125W	50139	BCK1002FT
A4R103	321-5030-00			RES,FXD:THICK FILM;10.0K OHM,1%,0.125W	50139	BCK1002FT
A4R104	321-5030-00			RES,FXD:THICK FILM;10.0K OHM,1%,0.125W	50139	BCK1002FT
A4R106	321-5030-00			RES,FXD:THICK FILM;10.0K OHM,1%,0.125W	50139	BCK1002FT
A4R107	321-5030-00			RES,FXD:THICK FILM;10.0K OHM,1%,0.125W	50139	BCK1002FT
A4R108	321-5018-00			RES,FXD:THICK FILM;1.0K OHM,1%,0.125W	50139	BCK1001FT
A4R109	321-5030-00			RES,FXD:THICK FILM;10.0K OHM,1%,0.125W	50139	BCK1002FT
A4R140	321-5049-00			RES,FXD:THICK FILM;1M OHM,1%,0.125W	57668	MCR18FXEA1M
A4R201	321-5014-00			RES,FXD:THICK FILM;475 OHM,1%,0.125W	50139	BCK4750FT
A4R202	321-5014-00			RES,FXD:THICK FILM;475 OHM,1%,0.125W	50139	BCK4750FT
A4R203	321-5014-00			RES,FXD:THICK FILM;475 OHM,1%,0.125W	50139	BCK4750FT
A4R204	321-5014-00			RES,FXD:THICK FILM;475 OHM,1%,0.125W	50139	BCK4750FT
A4R205	321-5014-00			RES,FXD:THICK FILM;475 OHM,1%,0.125W	50139	BCK4750FT
A4R206	321-5014-00			RES,FXD:THICK FILM;475 OHM,1%,0.125W	50139	BCK4750FT
A4R207	321-5014-00			RES,FXD:THICK FILM;475 OHM,1%,0.125W	50139	BCK4750FT
A4R208	321-5014-00			RES,FXD:THICK FILM;475 OHM,1%,0.125W	50139	BCK4750FT
A4R300	321-5047-00			RES,FXD:THICK FILM;100K OHM,1%,0.125W	50139	BCK1003FT
A4R301	321-5047-00			RES,FXD:THICK FILM;100K OHM,1%,0.125W	50139	BCK1003FT
A4R302	321-5047-00			RES,FXD:THICK FILM;100K OHM,1%,0.125W	50139	BCK1003FT
A4R303	321-5047-00			RES,FXD:THICK FILM;100K OHM,1%,0.125W	50139	BCK1003FT
A4R304	321-5047-00			RES,FXD:THICK FILM;100K OHM,1%,0.125W	50139	BCK1003FT
A4R305	321-5047-00			RES,FXD:THICK FILM;100K OHM,1%,0.125W	50139	BCK1003FT
A4R306	321-5047-00			RES,FXD:THICK FILM;100K OHM,1%,0.125W	50139	BCK1003FT
A4R307	321-5047-00			RES,FXD:THICK FILM;100K OHM,1%,0.125W	50139	BCK1003FT
A4R330	321-5014-00			RES,FXD:THICK FILM;475 OHM,1%,0.125W	50139	BCK4750FT
A4R331	321-5014-00			RES,FXD:THICK FILM;475 OHM,1%,0.125W	50139	BCK4750FT
A4R332	321-5014-00			RES,FXD:THICK FILM;475 OHM,1%,0.125W	50139	BCK4750FT
A4R333	321-5014-00			RES,FXD:THICK FILM;475 OHM,1%,0.125W	50139	BCK4750FT
A4R334	321-5014-00			RES,FXD:THICK FILM;475 OHM,1%,0.125W	50139	BCK4750FT
A4R335	321-5014-00			RES,FXD:THICK FILM;475 OHM,1%,0.125W	50139	BCK4750FT
A4R336	321-5014-00			RES,FXD:THICK FILM;475 OHM,1%,0.125W	50139	BCK4750FT
A4R337	321-5014-00			RES,FXD:THICK FILM;475 OHM,1%,0.125W	50139	BCK4750FT
A4R411	321-5018-00			RES,FXD:THICK FILM;1.0K OHM,1%,0.125W	50139	BCK1001FT
A4R412	321-5018-00			RES,FXD:THICK FILM;1.0K OHM,1%,0.125W	50139	BCK1001FT
A4R413	321-5018-00			RES,FXD:THICK FILM;1.0K OHM,1%,0.125W	50139	BCK1001FT

Replaceable Electrical Parts List

Component Number	Tektronix Part No.	Serial No.		Name & Description	Mfr. Code	Mfr. Part No.
		Effective	Dscont			
A4R414	321-5018-00			RES,FXD:THICK FILM;1.0K OHM,1%,0.125W	50139	BCK1001FT
A4R450	311-2843-00			RES,VAR,NONWW:SHAFTLESS,SNAP IN MOUNT	32997	11508004
A4R451	311-2843-00			RES,VAR,NONWW:SHAFTLESS,SNAP IN MOUNT	32997	11508004
A4R452	311-2843-00			RES,VAR,NONWW:SHAFTLESS,SNAP IN MOUNT	32997	11508004
A4R453	311-2843-00			RES,VAR,NONWW:SHAFTLESS,SNAP IN MOUNT	32997	11508004
A4R460	321-5047-00			RES,FXD:THICK FILM;100K OHM,1%,0.125W	50139	BCK1003FT
A4R461	321-5047-00			RES,FXD:THICK FILM;100K OHM,1%,0.125W	50139	BCK1003FT
A4R462	321-5047-00			RES,FXD:THICK FILM;100K OHM,1%,0.125W	50139	BCK1003FT
A4R463	321-5047-00			RES,FXD:THICK FILM;100K OHM,1%,0.125W	50139	BCK1003FT
A4R464	321-5047-00			RES,FXD:THICK FILM;100K OHM,1%,0.125W	50139	BCK1003FT
A4R465	321-5047-00			RES,FXD:THICK FILM;100K OHM,1%,0.125W	50139	BCK1003FT
A4R466	321-5047-00			RES,FXD:THICK FILM;100K OHM,1%,0.125W	50139	BCK1003FT
A4R467	321-5047-00			RES,FXD:THICK FILM;100K OHM,1%,0.125W	50139	BCK1003FT
A4R468	321-5047-00			RES,FXD:THICK FILM;100K OHM,1%,0.125W	50139	BCK1003FT
A4R469	321-5047-00			RES,FXD:THICK FILM;100K OHM,1%,0.125W	50139	BCK1003FT
A4R501	321-5018-00			RES,FXD:THICK FILM;1.0K OHM,1%,0.125W	50139	BCK1001FT
A4R503	321-5030-00			RES,FXD:THICK FILM;10.0K OHM,1%,0.125W	50139	BCK1002FT
A4R504	321-5027-00			RES,FXD:THICK FILM;5.62K OHM,1%,0.125W	50139	BCK5621FT
A4R505	321-5025-00			RES,FXD:THICK FILM;3.92K OHM,1%,0.125W	50139	BCK3921FT
A4U101	160-7853-06			IC,PROCESSOR:CMOS,MICROCOMPUTER;8-BIT	04713	MC68HC705B5FN
A4U202	156-5458-00			IC,DIGITAL:HCMOS,LATCH;8-BIT ADDRESSABLE	04713	MC74HC259D
A4U304	156-6135-01			IC,DIGITAL:HCMOS,DEMUX/DECODER;3-TO-8	0JR04	TC74HC138AFN(EL
A4U305	156-6135-01			IC,DIGITAL:HCMOS,DEMUX/DECODER;3-TO-8	0JR04	TC74HC138AFN(EL
A4U420	156-5050-01			IC,MISC:HCMOS,ANALOG MUX;8-CHANNEL	1CH66	74HC4051DT
A4U421	156-5050-01			IC,MISC:HCMOS,ANALOG MUX;8-CHANNEL	1CH66	74HC4051DT
A4Y140	119-4061-00			RESONATOR,CERAM:2.4576MHZ,50VAC,0.5%	20932	KBR-2.45MS

Component Number	Tektronix Part No.	Serial No.		Name & Description	Mfr. Code	Mfr. Part No.
		Effective	Dscont			
A5	671-2221-01	B010100	B010160	CIRCUIT BD ASSY:CPU (TAS475 ONLY)	80009	671222101
A5	671-2221-02	B010161	B010570	CIRCUIT BD ASSY:CPU (TAS475 ONLY)	80009	671222102
A5	671-2221-03	B010571		CIRCUIT BD ASSY:CPU (TAS475 ONLY)	80009	671222103
A5	671-2221-01	B010100	B010136	CIRCUIT BD ASSY:CPU (TAS485 ONLY)	80009	671222101
A5	671-2221-02	B010137	B010320	CIRCUIT BD ASSY:CPU (TAS485 ONLY)	80009	671222102
A5	671-2221-03	B010321		CIRCUIT BD ASSY:CPU (TAS485 ONLY)	80009	671222103
A5C201	290-5034-01			CAP,FXD,ALUM::33UF,20%,10V,5.7MM(0.224)	1W344	MVK10VC33RME60T
A5C202	283-5004-00			CAP,FXD,CERAMIC:MLC;0.1UF,10%,25V,X7R,1206	04222	12063C104KAT3A
A5C203	283-5195-00			CAP,FXD,CERAMIC:MLC;10PF,5%,100V ,COG,1206	04222	12061A100JAT1A
A5C204	283-5007-00			CAP,FXD,CERAMIC:MLC;8PF,+/-0.5PF,50V,NPO	04222	12061A8R0DATMA
A5C205	283-5004-00			CAP,FXD,CERAMIC:MLC;0.1UF,10%,25V,X7R,1206	04222	12063C104KAT3A
A5C206	283-5004-00			CAP,FXD,CERAMIC:MLC;0.1UF,10%,25V,X7R,1206	04222	12063C104KAT3A
A5C207	283-5004-00			CAP,FXD,CERAMIC:MLC;0.1UF,10%,25V,X7R,1206	04222	12063C104KAT3A
A5C208	283-5004-00			CAP,FXD,CERAMIC:MLC;0.1UF,10%,25V,X7R,1206	04222	12063C104KAT3A
A5C209	283-5004-00			CAP,FXD,CERAMIC:MLC;0.1UF,10%,25V,X7R,1206	04222	12063C104KAT3A
A5C211	283-5195-00			CAP,FXD,CERAMIC:MLC;10PF,5%,100V ,COG,1206	04222	12061A100JAT1A
A5C212	283-5107-00			CAP,FXD,CERAMIC:MLC;22PF,5%,100V,NPO,1206	04222	12061A220JAT1A
A5C213	283-5107-00			CAP,FXD,CERAMIC:MLC;22PF,5%,100V,NPO,1206	04222	12061A220JAT1A
A5C214	283-5004-00			CAP,FXD,CERAMIC:MLC;0.1UF,10%,25V,X7R,1206	04222	12063C104KAT3A
A5C215	283-5004-00			CAP,FXD,CERAMIC:MLC;0.1UF,10%,25V,X7R,1206	04222	12063C104KAT3A
A5C216	283-5004-00			CAP,FXD,CERAMIC:MLC;0.1UF,10%,25V,X7R,1206	04222	12063C104KAT3A
A5C217	283-5195-00			CAP,FXD,CERAMIC:MLC;10PF,5%,100V ,COG,1206	04222	12061A100JAT1A
A5C218	283-5195-00			CAP,FXD,CERAMIC:MLC;10PF,5%,100V ,COG,1206	04222	12061A100JAT1A
A5C219	283-5107-00			CAP,FXD,CERAMIC:MLC;22PF,5%,100V,NPO,1206	04222	12061A220JAT1A
A5C220	283-5107-00			CAP,FXD,CERAMIC:MLC;22PF,5%,100V,NPO,1206	04222	12061A220JAT1A
A5C221	283-5107-00			CAP,FXD,CERAMIC:MLC;22PF,5%,100V,NPO,1206	04222	12061A220JAT1A
A5C223	283-5004-00	B010571		CAP,FXD,CERAMIC:MLC;0.1UF,10%,25V,X7R,1206 (TAS475 ONLY)	04222	12063C104KAT3A
A5C223	283-5004-00	B010321		CAP,FXD,CERAMIC:MLC;0.1UF,10%,25V,X7R,1206 (TAS485 ONLY)	04222	12063C104KAT3A
A5C224	283-5004-00	B010571		CAP,FXD,CERAMIC:MLC;0.1UF,10%,25V,X7R,1206 (TAS475 ONLY)	04222	12063C104KAT3A
A5C224	283-5004-00	B010321		CAP,FXD,CERAMIC:MLC;0.1UF,10%,25V,X7R,1206 (TAS485 ONLY)	04222	12063C104KAT3A
A5C225	283-5004-00	B010571		CAP,FXD,CERAMIC:MLC;0.1UF,10%,25V,X7R,1206 (TAS475 ONLY)	04222	12063C104KAT3A
A5C225	283-5004-00	B010321		CAP,FXD,CERAMIC:MLC;0.1UF,10%,25V,X7R,1206 (TAS485 ONLY)	04222	12063C104KAT3A

Replaceable Electrical Parts List

Component Number	Tektronix Part No.	Serial No.		Name & Description	Mfr. Code	Mfr. Part No.
		Effective	Dscont			
A5J30	131-5344-00			CONN,HDR:PCB,;MALE,STR,1 X 16,0.1 CTR	00779	1-103670-5
A5J50	131-5346-00			CONN,HDR:PCB,;MALE,STR,2 X 20,0.1 CTR	00779	104338-8
A5J55	131-4807-00			CONN,HDR PWR:PCB,;MALE,STR,1 X 5,0.156 CTR	00779	640444-5
A5J204	131-3147-00			CONN,HDR:PCB,;MALE,STR,2 X 25,0.1 CTR	53387	2550-6002UB
A5Q1	151-5001-00			TRANSISTOR,SIG:BIPOLAR,NPN;40V,200MA	04713	MMBT3904LT1
A5Q2	151-5001-00			TRANSISTOR,SIG:BIPOLAR,NPN;40V,200MA	04713	MMBT3904LT1
A5R201	321-5208-00			RES,FXD:THICK FILM;10M OHM,5%,0.125W	91637	CRCW1206-106JT
A5R202	321-5048-00			RES,FXD:THICK FILM;332K OHM,1%,0.125W	57668	MCR18FXEA332K
A5R203	321-5212-00			RES,FXD,FILM:4.99K OHM,1%,0.125W100PPM/DEG	91637	CRCW-12064991F
A5R204	321-5212-00			RES,FXD,FILM:4.99K OHM,1%,0.125W100PPM/DEG	91637	CRCW-12064991F
A5R205	321-5212-00			RES,FXD,FILM:4.99K OHM,1%,0.125W100PPM/DEG	91637	CRCW-12064991F
A5R206	321-5212-00			RES,FXD,FILM:4.99K OHM,1%,0.125W100PPM/DEG	91637	CRCW-12064991F
A5R207	307-5020-00			RES NTWK,FXD,FI:10K X 8,1%,0.250W	91637	SOMC-1603-1002F
A5R208	307-5020-00			RES NTWK,FXD,FI:10K X 8,1%,0.250W	91637	SOMC-1603-1002F
A5R209	307-5020-00			RES NTWK,FXD,FI:10K X 8,1%,0.250W	91637	SOMC-1603-1002F
A5R210	321-5010-00			RES,FXD:THICK FILM;221 OHM,1%,0.125W	50139	BCK221FT
A5R211	321-5007-00			RES,FXD:THICK FILM;121 OHM,1%,0.125W	50139	BCK1210FT
A5R212	321-5010-00			RES,FXD:THICK FILM;221 OHM,1%,0.125W	50139	BCK221FT
A5R213	321-5007-00			RES,FXD:THICK FILM;121 OHM,1%,0.125W	50139	BCK1210FT
A5R214	321-5010-00			RES,FXD:THICK FILM;221 OHM,1%,0.125W	50139	BCK221FT
A5R217	321-5010-00			RES,FXD:THICK FILM;221 OHM,1%,0.125W	50139	BCK221FT
A5R220	321-5000-00			RES,FXD:THICK FILM;10 OHM,1%,0.125W	91637	CRCW120610R0FT
A5R221	321-5000-00			RES,FXD:THICK FILM;10 OHM,1%,0.125W	91637	CRCW120610R0FT
A5R222	321-5022-00			RES,FXD:THICK FILM;2.21K OHM,1%,0.125W	50139	BCK2211FT
A5R223	321-5212-00			RES,FXD,FILM:4.99K OHM,1%,0.125W100PPM/DEG	91637	CRCW-12064991F
A5R224	321-5007-00			RES,FXD:THICK FILM;121 OHM,1%,0.125W	50139	BCK1210FT
A5R225	321-5007-00			RES,FXD:THICK FILM;121 OHM,1%,0.125W	50139	BCK1210FT
A5R227	321-5029-00			RES,FXD:THICK FILM;8.25K OHM,1%,0.125W	50139	BCK8251FT
A5R228	321-5029-00			RES,FXD:THICK FILM;8.25K OHM,1%,0.125W	50139	BCK8251FT
A5R230	321-5051-00			RES,FXD:THICK FILM;0 OHM,1%,0.125W	09969	CRCW1206 JUMPER
A5U201	156-6298-00			IC,PROCESSOR:CMOS,MICROCONTROLLER	04713	MC68331CFC16
A5U202	156-6151-00			IC,MEMORY:CMOS,SRAM;128K X 8,100NS,15UA	TK1146	M5M51008FP-10LL
A5U203	156-6151-00			IC,MEMORY:CMOS,SRAM;128K X 8,100NS,15UA	TK1146	M5M51008FP-10LL
A5U205	156-6461-01	B010100	B010570	IC,MEMORY:CMOS,EPROM;256K X 8,150NS FLASH (TAS475 ONLY)	80009	156646101
A5U205	156-6085-01	B010571		IC,MEMORY:CMOS,EPROM;128K X 8,200NS FLASH (TAS475 ONLY)	80009	156646101
A5U205	156-6461-01	B010100	B010320	IC,MEMORY:CMOS,EPROM;256K X 8,150NS FLASH (TAS485 ONLY)	80009	156646101
A5U205	156-6085-01	B010321		IC,MEMORY:CMOS,EPROM;128K X 8,200NS FLASH (TAS485 ONLY)	80009	156646101
A5U206	156-6461-01	B010100	B010570	IC,MEMORY:CMOS,EPROM;256K X 8,150NS FLASH (TAS475 ONLY)	80009	156646101

Component Number	Tektronix Part No.	Serial No.		Name & Description	Mfr. Code	Mfr. Part No.
		Effective	Dscont			
A5U206	156-6085-01	B010571		IC, MEMORY: CMOS, EPROM; 128K X 8, 200NS FLASH (TAS475 ONLY)	80009	156646101
A5U206	156-6461-01	B010100	B010320	IC, MEMORY: CMOS, EPROM; 256K X 8, 150NS FLASH (TAS485 ONLY)	80009	156646101
A5U206	156-6085-01	B010321		IC, MEMORY: CMOS, EPROM; 128K X 8, 200NS FLASH (TAS485 ONLY)	80009	156646101
A5U207	156-6101-01			IC, MISC: BIPOLAR, PWR SUPPLY SUPERVISOR	04713	MC34164D-5R2
A5U208	156-4224-00			IC, MEMORY: CMOS, NVRAM; 8K X 8, 100NS	0B0A9	DS1225D-100
A5U215	156-6031-00			IC, PROCESSOR: NMOS, PERIPHERAL	04713	MC68681FN
A5U217	156-6325-00			IC, ASIC: CMOS, CUSTOM; CHARACTER DSPLYGEN	80009	156632500
A5U218	156-5157-01			IC, CONVERTER: BIPOLAR, D/A; 12 BIT, 300NS, MULTI	1CH66	AM6012DT (D/C88)
A5U219	156-5157-01			IC, CONVERTER: BIPOLAR, D/A; 12 BIT, 300NS, MULTI	1CH66	AM6012DT (D/C88)
A5U220	156-5588-01			IC, LINEAR: BIPOLAR, VOLT REF; POSI, 2.5V, 1.0%	04713	MC1403D
A5U221	156-5051-01			IC, DIGITAL: FTTL, GATE; QUAD 2-INPUT NOR	04713	MC74F02DR2
A5U222	156-5054-01	B010571		IC, DIGITAL: FTTL, GATE; QUAD 2-INPUT NOR (TAS475 ONLY)	80009	156505401
A5U222	156-5054-01	B010321		IC, DIGITAL: FTTL, GATE; QUAD 2-INPUT NOR (TAS485 ONLY)	80009	156505401
A5U223	156-6085-01	B010571		IC, MEMORY: CMOS, EPROM; 128K X 8, 200NS FLASH (TAS475 ONLY)	80009	156646101
A5U223	156-6085-01	B010321		IC, MEMORY: CMOS, EPROM; 128K X 8, 200NS FLASH (TAS485 ONLY)	80009	156646101
A5U224	156-6085-01	B010571		IC, MEMORY: CMOS, EPROM; 128K X 8, 200NS FLASH (TAS475 ONLY)	80009	156646101
A5U224	156-6085-01	B010321		IC, MEMORY: CMOS, EPROM; 128K X 8, 200NS FLASH (TAS485 ONLY)	80009	156646101
A5Y201	158-5013-00			XTAL UNIT QTZ: 32.768KHZ, +/- 0.002%, RS 60K	61429	FSM327
A5Y202	158-5012-00			XTAL UNIT QTZ: 3.6864MHZ, +/- 0.005%, ESR 150	61429	HC49SG

Replaceable Electrical Parts List

Component Number	Tektronix Part No.	Serial No. Effective	Dscont	Name & Description	Mfr. Code	Mfr. Part No.
A9	259-0091-00			FLEX CIRCUIT:BEZEL	80009	259009100
A62	672-1362-00			CIRCUIT BD ASSY:FRONT PANEL MODULE (TAS475 ONLY)	80009	672136200
A62	672-1395-00			CIRCUIT BD ASSY:FRONT PANEL MODULE (TAS485 ONLY)	80009	672139500
A63	119-5024-00			POWER SUPPLY:LOW POWER VERSION	TK6056	119-5024-00
A64	154-0905-01			ELECTRON TUBE:CRT (TAS475 ONLY)	80009	154090501
A64	154-0972-00			ELECTRON TUBE:CRT (TAS485 ONLY)	80009	154097200
CHASSIS PARTS						
B90	119-1770-04			FAN,DC:TUBEAXIAL;12V,1.72W,35CFM,W/CONN	S4246	CUDC12D4
DL68	119-5023-00			DELAY LINE,ELEC:VERTICAL (TAS475 ONLY)	TK2469	119-5023-00
DL68	119-5034-00			DELAY LINE,ELEC:VERTICAL (TAS485 ONLY)	TK2469	119-5034-00
J21	174-3005-00			CA ASSY RF:DISCRETE,;SDI/RFD,22 AWG,8.625 L (WITH P66)	0J7N9	ORDER BY DESC
P30	174-2598-00			CA ASSY,SP:FLAT FLEX,;FLX,16,26 AWG,13.7 L (FRONT PANEL/CPU)	80009	174259800
P50	174-2600-00			CA ASSY,SP:RIBBON,;IDC,40,28 AWG,3.5 L,2X20 (CPU/ANALOG)	80009	174260000
P74	196-3374-00			LEAD,ELECTRICAL:DISCRETE,;SDI/IDC,2,22 AWG (VERTICAL, QTY 2, TAS475 ONLY)	0J7N9	196-3374-00
P75	196-3375-00			LEAD,ELECTRICAL:DISCRETE,;SDI/IDC,2,22 AWG (HORIZ DEFL LEAD, QTY 2, TAS475 ONLY)	0J7N9	196-3375-00
P75	196-3390-00			LEAD,ELECTRICAL:DISCRETE,;SDI/IDC,2,22 AWG (HORIZ DEFL LEAD, QTY 2, TAS485 ONLY)	0J7N9	196-3390-00
P76	198-5790-00			CA ASSY,SP:DISCRETE,;SDI,9,26 AWG,7.4 L	0J7N9	198-5790-00
P80	174-2601-00			CA ASSY,SP:FLAT FLEX,;FLX,2,26 AWG,7.65 L (DC/DD)	80009	174260100
P84	174-2284-00			CA ASSY,SP:FLAT FLEX,;FLX,5,26 AWG,8.7 L (DC/FP)	80009	174228400

Diagrams and Circuit Board Illustrations

This section contains circuit board illustrations, component locator tables, waveform illustrations, and schematic diagrams for this oscilloscope.

Symbols

Graphic symbols and class designation letters are based on ANSI Standard Y32.2-1975. Abbreviations are based on ANSI Y1.1-1972.

Logic symbology is based on ANSI/IEEE Std 91-1984 in terms of positive logic. Logic symbols depict the logic function performed and can differ from the manufacturer's data.

The tilde (~) preceding a signal name indicates that the signal performs its intended function when in the low state.

Other standards used in the preparation of diagrams by Tektronix, Inc are:

- Tektronix Standard 062-2476 Symbols and Practices for Schematic Drafting
- ANSI Y14.159-1971 Interconnection Diagrams
- ANSI Y32.16-1975 Reference Designations for Electronic Equipment
- MIL-HDBK-63038-1A Military Standard Technical Manual Writing Handbook

Component Values

Electrical components shown on the diagrams are in the following units unless noted otherwise:

Capacitors: Values one or greater are in picofarads (pF). Values less than one are in microfarads (μ F).

Resistors: Values are in Ohms (Ω).

Graphic Items and Special Symbols Used in This Manual

Each assembly in the instrument is assigned an assembly identifier (for example, MAIN or A5). The assembly identifier appears on the circuit board outline on the diagram (see Figure 9-1), in the title for the circuit board component location illustration, and in the lookup table for the schematic diagram and corresponding component locator illustration. The Replaceable Electrical Parts list is arranged by assemblies in numerical sequence; the components are listed by component number.

Diagrams and Circuit Board Illustrations

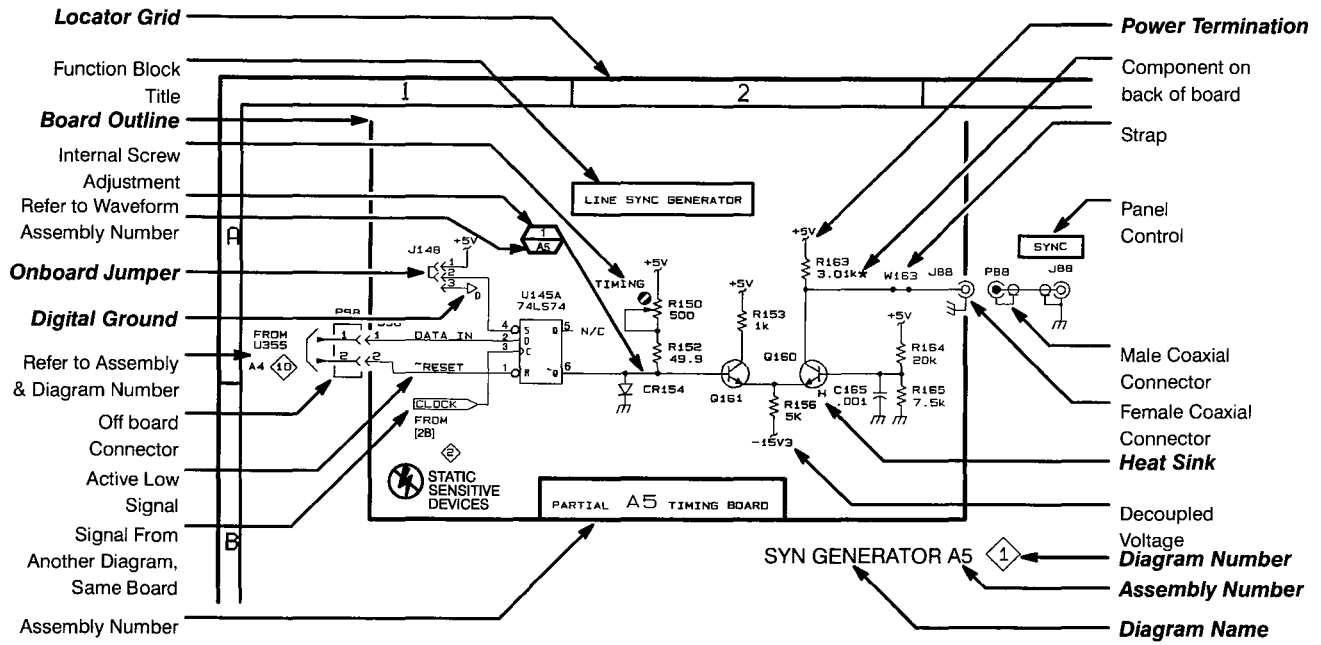

Figure 9-1: Graphic Items and Special Symbols Used in This Manual

Component Locator Diagrams

The schematic diagram and circuit board component location illustrations have grids. A lookup table is provided for ease of locating a component. The circuit board illustration only appears once; its lookup table lists the diagram number of all diagrams that the circuitry appears on.

Some of the circuit board component location illustrations are expanded and divided into several parts to make it easier for you to locate small components. To determine which part of the whole locator diagram you are looking at, refer to the small locator key positioned at the upper left of each circuit board component locator diagram, as shown in Figure 9-2. The gray block, within the larger circuit board outline, shows where that part fits in the whole locator diagram. Each part in the key is labeled with an identifying letter which appears in the figure titles under component locator diagrams.

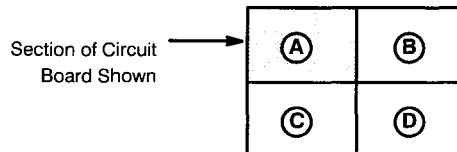
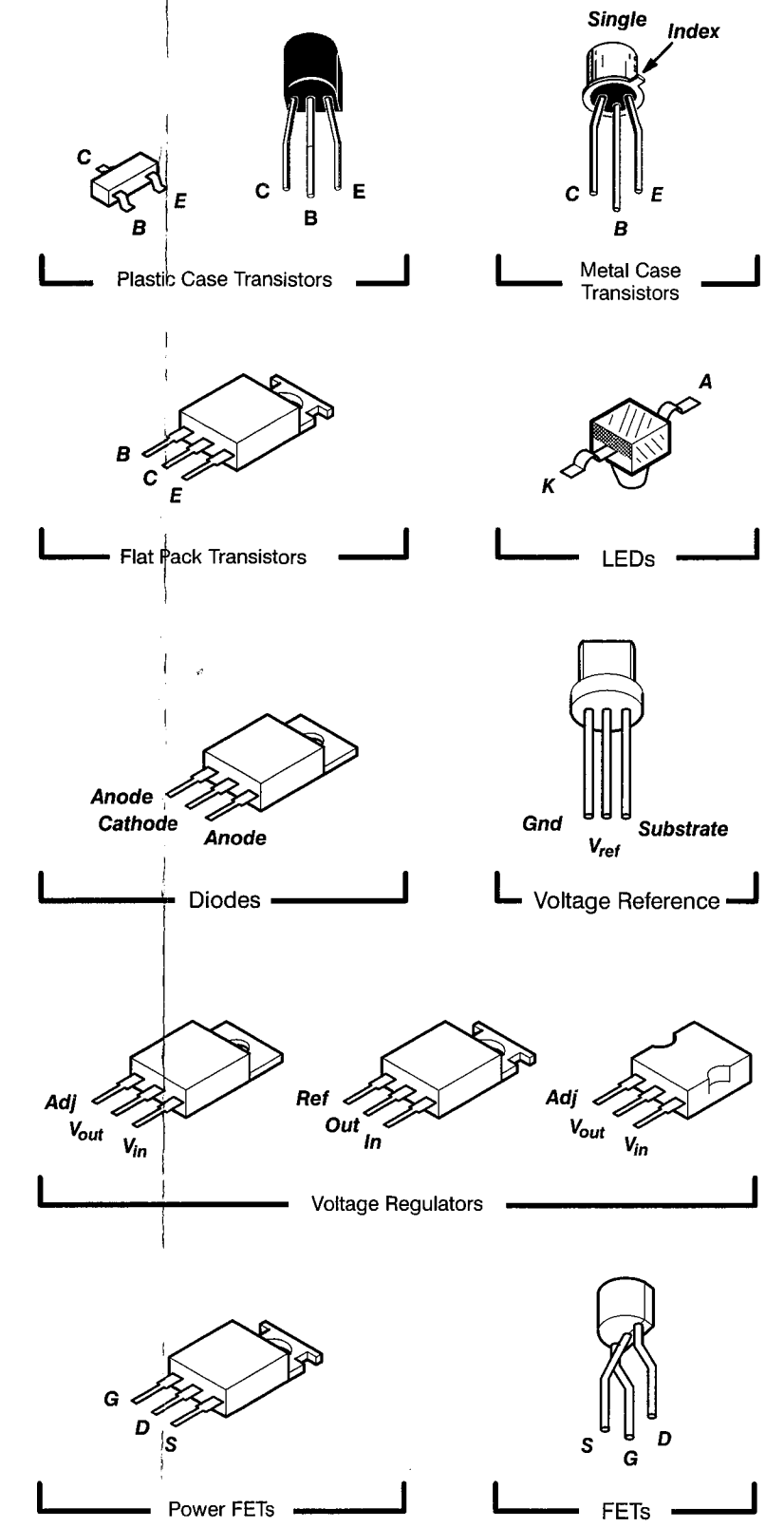
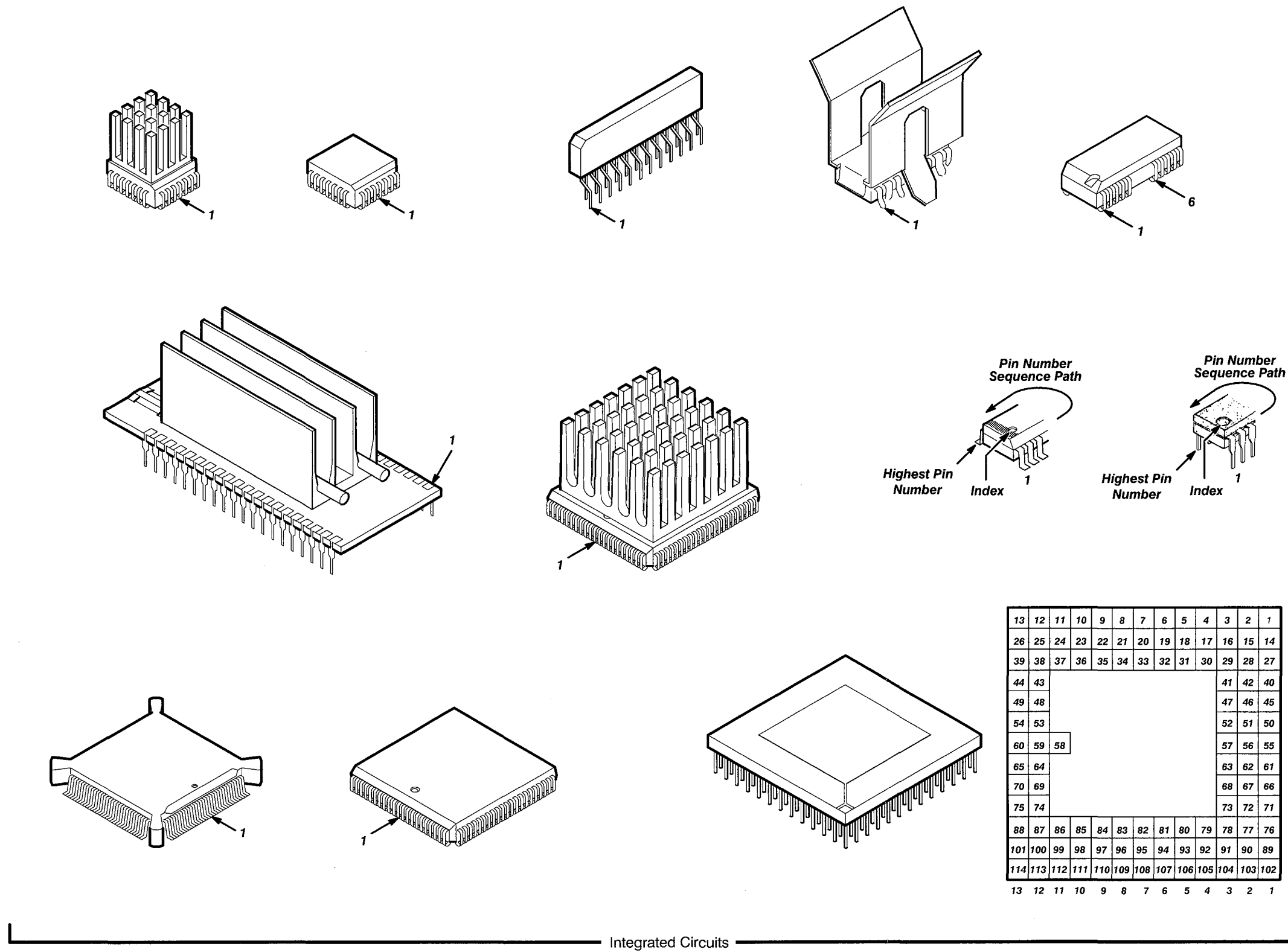

Figure 9-2: Circuit Board Component Locator Diagram Key



Lead configurations and case styles are typical, but may vary due to vendor changes or instrument modifications.

Figure 9-3: Semiconductor Lead Configurations

LOCATING COMPONENTS ON THE CIRCUIT BOARD OR SCHEMATIC DIAGRAM

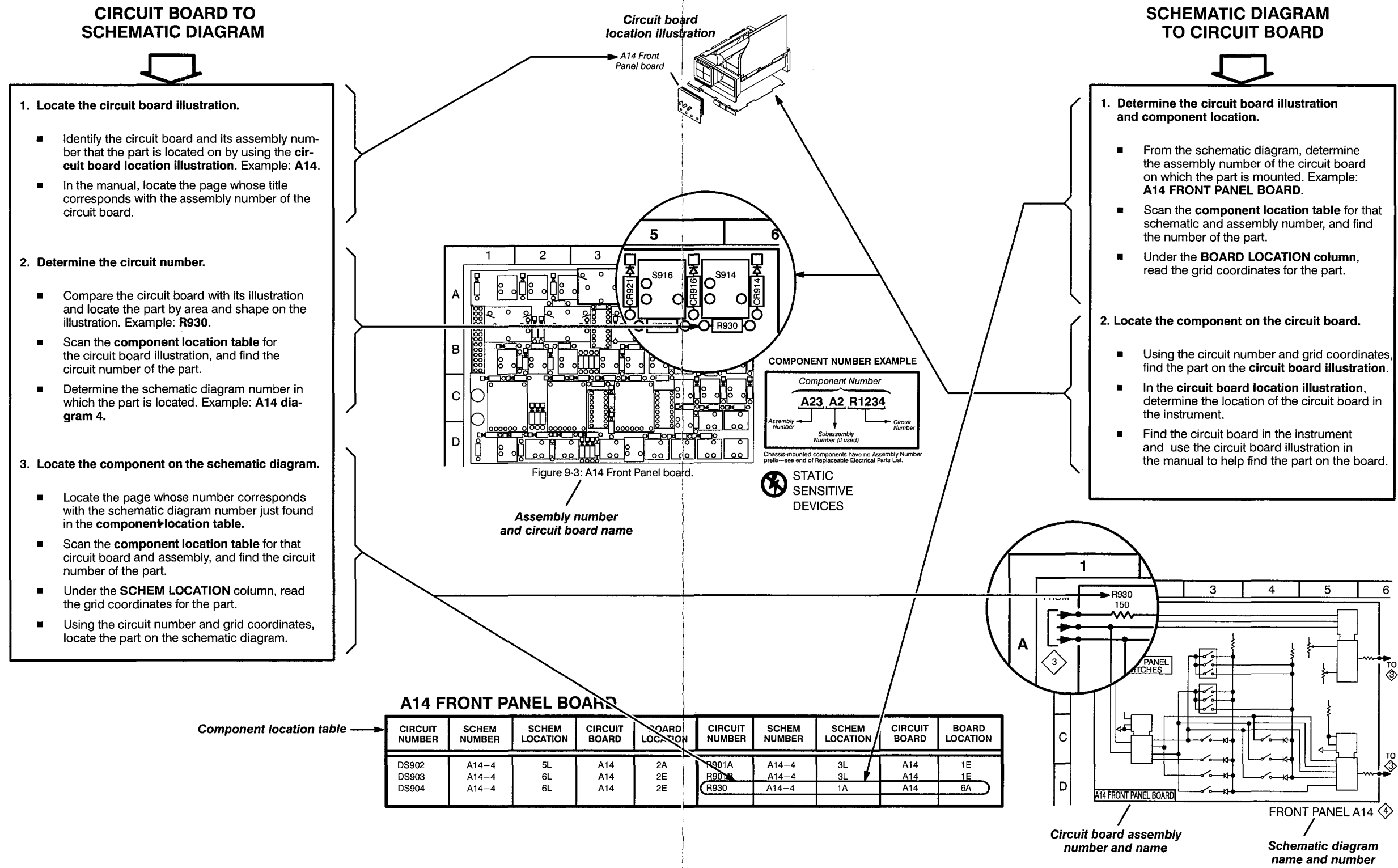
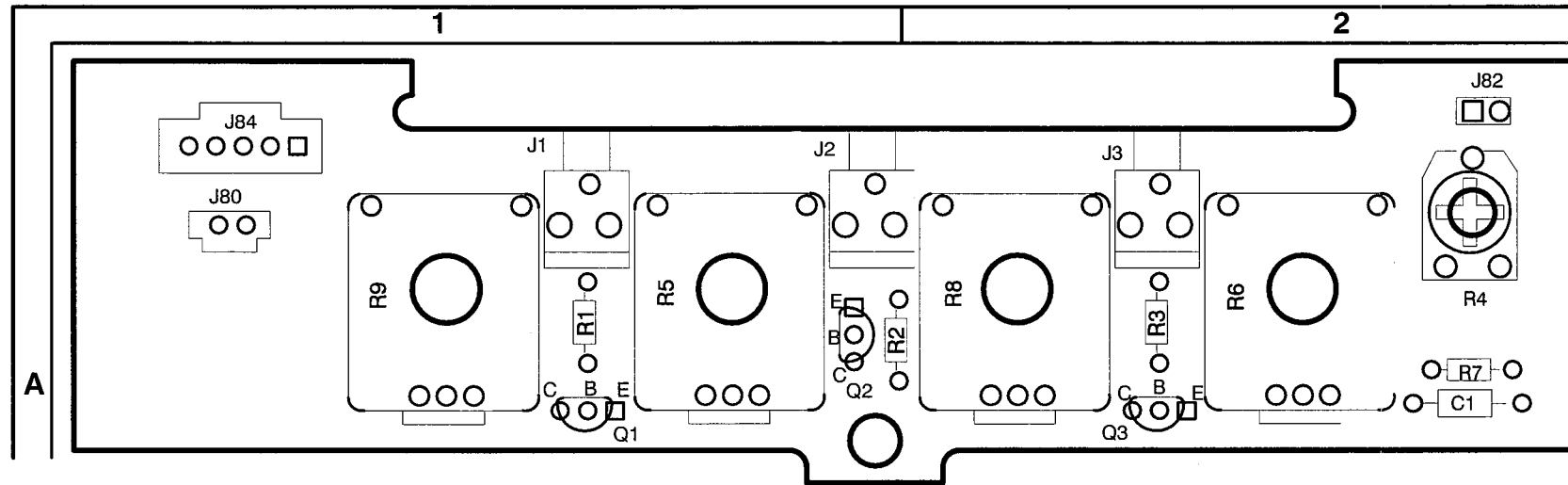
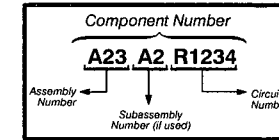

Figure 9-4: Locating Components on Circuit Board or Schematic Diagram



389-1221-00
671-2222-00

COMPONENT NUMBER EXAMPLE



Chassis-mounted components have no Assembly Number prefix—see end of Replaceable Electrical Parts List.

STATIC SENSITIVE DEVICES

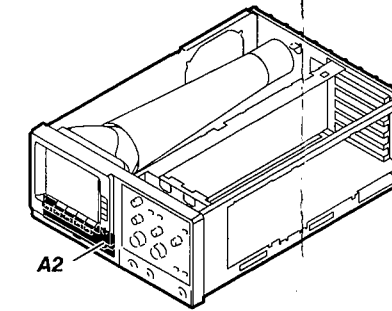

A2 Display Control Component Locator

CIRCUIT NUMBER	SCHEM NUMBER	SCHEM LOCATION	BOARD NUMBER	BOARD LOCATION	CIRCUIT NUMBER	SCHEM NUMBER	SCHEM LOCATION	BOARD NUMBER	BOARD LOCATION	CIRCUIT NUMBER	SCHEM NUMBER	SCHEM LOCATION	BOARD NUMBER	BOARD LOCATION	CIRCUIT NUMBER	SCHEM NUMBER	SCHEM LOCATION	BOARD NUMBER	BOARD LOCATION	CIRCUIT NUMBER	SCHEM NUMBER	SCHEM LOCATION	BOARD NUMBER	BOARD LOCATION
C1	A2-1	2C	A2	2A	J82	A2-1	4C	A2	2A	Q2	A2-1	2A	A2	1A	R2	A2-1	2A	A2	1A	R6	A2-1	1C	A2	2A
J2	A2-1	2B	A2	1A	J84	A2-1	4B	A2	1A	Q3	A2-1	3A	A2	2A	R3	A2-1	3A	A2	2A	R7	A2-1	4C	A2	2A
J3	A2-1	3B	A2	2A	Q1	A2-1	2A	A2	1A	R1	A2-1	2A	A2	1A	R4	A2-1	1C	A2	2A	R8	A2-1	1D	A2	1A
J80	A2-1	4D	A2	1A											R5	A2-1	1B	A2	1A	R9	A2-1	1A	A2	1A

Figure 9-5: A2 Display Control Board

A5 Processor Component Locator
(TAS 475 — SN B010570 and Below)
(TAS 485 — SN B010320 and Below)

CIRCUIT NUMBER	SCHEM NUMBER	SCHEM LOCATION	BOARD NUMBER	BOARD LOCATION	CIRCUIT NUMBER	SCHEM NUMBER	SCHEM LOCATION	BOARD NUMBER	BOARD LOCATION	CIRCUIT NUMBER	SCHEM NUMBER	SCHEM LOCATION	BOARD NUMBER	BOARD LOCATION	CIRCUIT NUMBER	SCHEM NUMBER	SCHEM LOCATION	BOARD NUMBER	BOARD LOCATION	CIRCUIT NUMBER	SCHEM NUMBER	SCHEM LOCATION	BOARD NUMBER	BOARD LOCATION
C201	A5-1	1A	A5	1A	C217	A5-4	4D	A5	1A	R202	A5-1	2B	A5	1A	R217	A5-1	2D	A5	1B	U205	A5-2	3B	A5	1A
C202	A5-1	2C	A5	2A	C218	A5-4	4D	A5	1A	R203	A5-4	5B	A5	1A	R218	A5-1	2D	A5	1B	U206	A5-2	4B	A5	2A
C203	A5-1	2C	A5	2B	C219	A5-1	2C	A5	2B	R204	A5-4	5B	A5	1A	R219	A5-1	2D	A5	1B	U207	A5-1	1C	A5	1A
C204	A5-1	2B	A5	1B	C220	A5-1	5C	A5	2B	R205	A5-4	5D	A5	1A	R220	A5-1	1D	A5	1A	U208	A5-1	5A	A5	2B
C205	A5-1	2A	A5	2A	C221	A5-1	2C	A5	2B	R206	A5-4	5B	A5	1A	R221	A5-1	1D	A5	1A	U215	A5-3	3A	A5	2A
C206	A5-2	2D	A5	2A						R207	A5-1	2A	A5	2B	R222	A5-1	2D	A5	1B	U217	A5-4	2A	A5	1A
C207	A5-2	4C	A5	2A	J30	A5-1	5D	A5	2B	R208	A5-1	1B	A5	2B	R223	A5-1	2D	A5	1B	U218	A5-4	5C	A5	1A
C208	A5-2	2B	A5	1A	J50	A5-1	6C	A5	1B	R209	A5-3	2A	A5	2A	R224	A5-4	4D	A5	1A	U219	A5-4	5A	A5	1A
C209	A5-2	4B	A5	2A	J55	A5-1	1C	A5	1A	R210	A5-1	1D	A5	1B	R225	A5-4	4D	A5	1A	U220	A5-4	4B	A5	1A
C210	A5-3	2C	A5	2A	J204	A5-1	6A	A5	2A	R211	A5-1	1D	A5	1B	R227	A5-4	6A	A5	1B	U221A	A5-2	1A	A5	1A
C211	A5-3	2C	A5	2A						R212	A5-1	1D	A5	1B	R228	A5-4	6A	A5	1B	U221B	A5-2	2A	A5	1A
C212	A5-4	5B	A5	1A	Q1	A5-1	1D	A5	1B	R213	A5-1	1D	A5	1B						U221C	A5-2	2A	A5	1A
C213	A5-4	5D	A5	1A	Q2	A5-1	2D	A5	1B	R214	A5-1	3D	A5	1B	U201	A5-1	3A	A5	2A					
C214	A5-4	2A	A5	1A						R215	A5-1	3D	A5	1B	U202	A5-2	3C	A5	2A					
C215	A5-4	5B	A5	1A	R201	A5-1	2C	A5	2A	R216	A5-1	3D	A5	1B	U203	A5-2	4C	A5	2A	Y201	A5-1	2C	A5	1A
C216	A5-4	6B	A5	1A																Y202	A5-3	2C	A5	2A

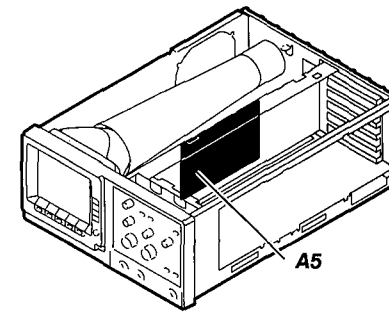
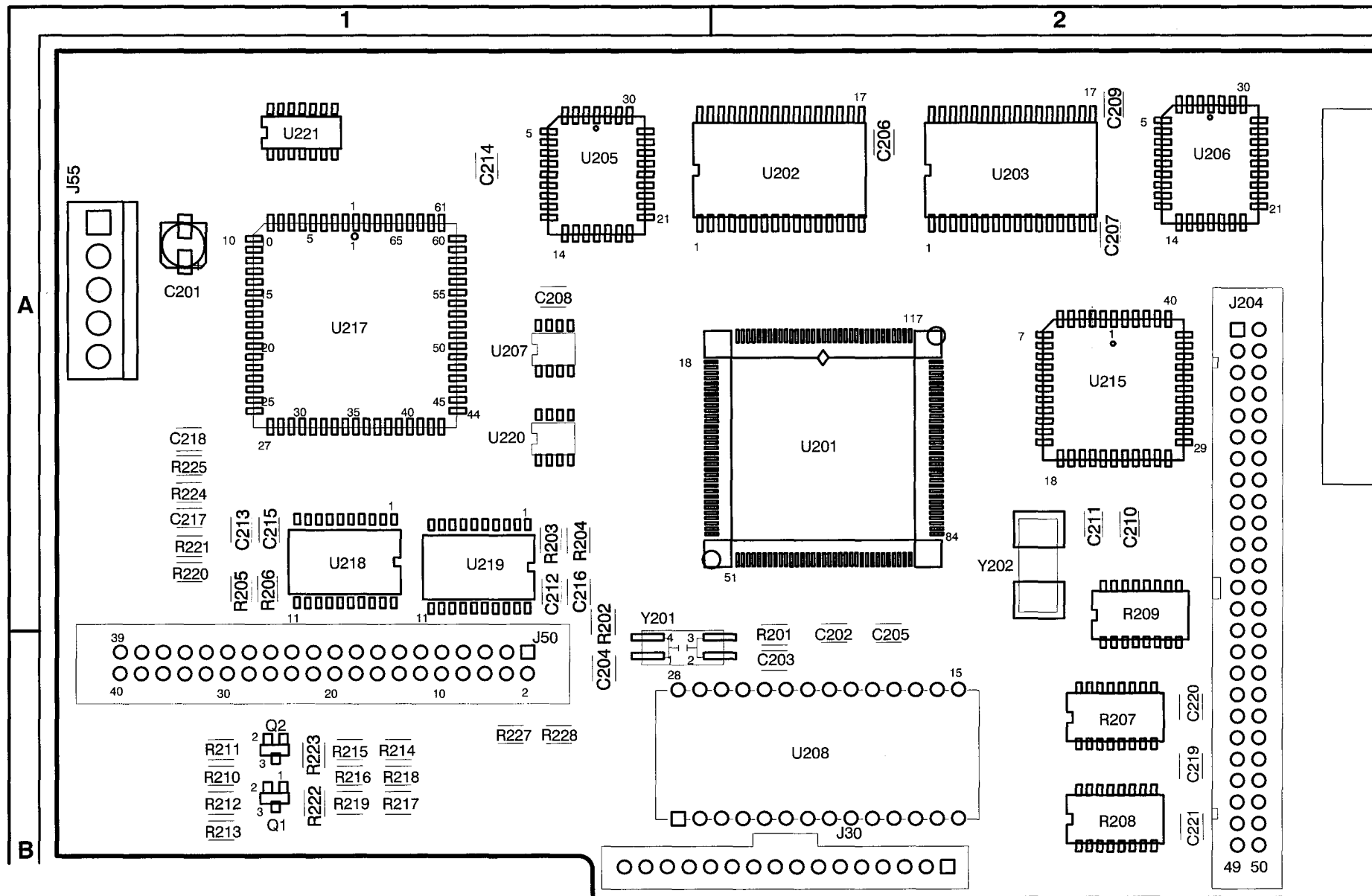

389-1220-00
671-2221-01
Q9C-1220-00

COMPONENT NUMBER EXAMPLE

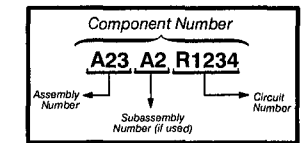

Chassis-mounted components have no Assembly Number prefix—see end of Replaceable Electrical Parts List.

STATIC SENSITIVE DEVICES

Figure 9-6: A5 Processor Board
TAS 475 — SN B010570 and Below
TAS 485 — SN B010320 and Below

A5 Processor Component Locator
(TAS 475 — SN B010571 and Above)
(TAS 485 — SN B010321 and Above)

CIRCUIT NUMBER	SCHEM NUMBER	SCHEM LOCATION	BOARD NUMBER	BOARD LOCATION	CIRCUIT NUMBER	SCHEM NUMBER	SCHEM LOCATION	BOARD NUMBER	BOARD LOCATION	CIRCUIT NUMBER	SCHEM NUMBER	SCHEM LOCATION	BOARD NUMBER	BOARD LOCATION	CIRCUIT NUMBER	SCHEM NUMBER	SCHEM LOCATION	BOARD NUMBER	BOARD LOCATION	CIRCUIT NUMBER	SCHEM NUMBER	SCHEM LOCATION	BOARD NUMBER	BOARD LOCATION
C201	A5-1	1A	A5	1A	C218	A5-4	4D	A5	1A	R202	A5-1	2B	A5	1A	R219	A5-1	2D	A5	1B	U208	A5-1	5A	A5	2B
C202	A5-1	2C	A5	2A	C219	A5-1	2C	A5	2B	R203	A5-4	5B	A5	1A	R220	A5-1	1D	A5	1A	U215	A5-3	3A	A5	2A
C203	A5-1	2C	A5	2B	C220	A5-1	5C	A5	2B	R204	A5-4	5B	A5	1A	R221	A5-1	1D	A5	1A	U217	A5-4	2A	A5	1A
C204	A5-1	2B	A5	1B	C221	A5-1	2C	A5	2B	R205	A5-4	5D	A5	1A	R222	A5-1	2D	A5	1B	U218	A5-4	5C	A5	1A
C205	A5-1	2A	A5	2A	C223	A5-2	6B	A5	1A	R206	A5-4	5B	A5	1A	R223	A5-1	2D	A5	1B	U219	A5-4	5A	A5	1A
C206	A5-2	2D	A5	1A	C224	A5-2	6C	A5	2A	R207	A5-1	2A	A5	2B	R224	A5-4	4D	A5	1A	U220	A5-4	4B	A5	1A
C207	A5-2	4C	A5	2A	C225	A5-4	3A	A5	1A	R208	A5-1	1B	A5	2B	R225	A5-4	4D	A5	1A	U221A	A5-2	1A	A5	1A
C208	A5-2	2B	A5	2A						R209	A5-3	2A	A5	2A	R227	A5-4	6A	A5	1B	U221B	A5-2	2A	A5	1A
C209	A5-2	4B	A5	2A	J30	A5-1	5D	A5	2B	R210	A5-1	1D	A5	1B	R228	A5-4	6A	A5	1B	U221C	A5-2	2A	A5	1A
C210	A5-3	2C	A5	2A	J50	A5-1	6C	A5	1B	R211	A5-1	1D	A5	1B	R230	A5-2	2A	A5	1A	U222A	A5-2	2A	A5	1A
C211	A5-3	2C	A5	2A	J55	A5-1	1C	A5	1A	R212	A5-1	1D	A5	1B						U222B	A5-2	2A	A5	1A
C212	A5-4	5B	A5	1A	J204	A5-1	6A	A5	2A	R213	A5-1	1D	A5	1B	U201	A5-1	3A	A5	2A	U223	A5-2	5B	A5	1A
C213	A5-4	5D	A5	1A						R214	A5-1	3D	A5	1B	U202	A5-2	3C	A5	1A	U224	A5-2	5C	A5	2A
C214	A5-4	2A	A5	1A	Q1	A5-1	1D	A5	1B	R215	A5-1	3D	A5	1B	U203	A5-2	4C	A5	2A					
C215	A5-4	5B	A5	1A	Q2	A5-1	2D	A5	1B	R216	A5-1	3D	A5	1B	U205	A5-2	3B	A5	1A	Y201	A5-1	2C	A5	1A
C216	A5-4	6B	A5	1A						R217	A5-1	2D	A5	1B	U206	A5-2	4B	A5	2A	Y202	A5-3	2C	A5	2A
C217	A5-4	4D	A5	1A	R201	A5-1	2C	A5	2A	R218	A5-1	2D	A5	1B	U207	A5-1	1C	A5	1A					

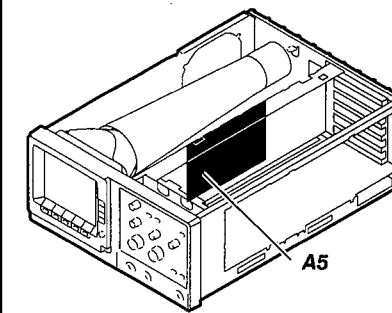
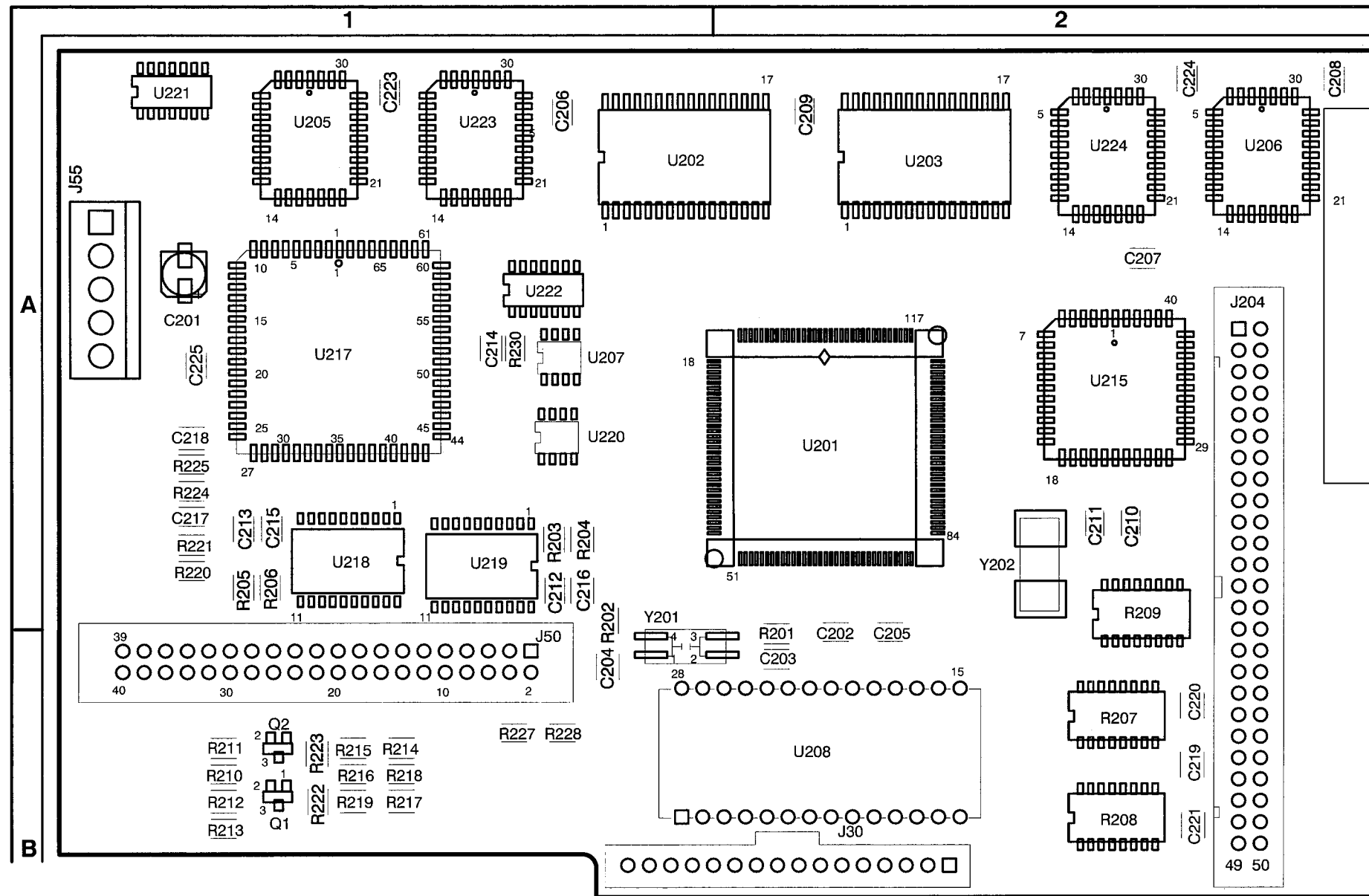

389-1220-01
671-2221-03
Q9A-1220-01

COMPONENT NUMBER EXAMPLE

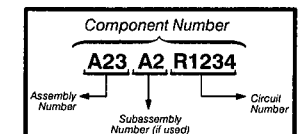

Chassis-mounted components have no Assembly Number prefix—see end of Replaceable Electrical Parts List.

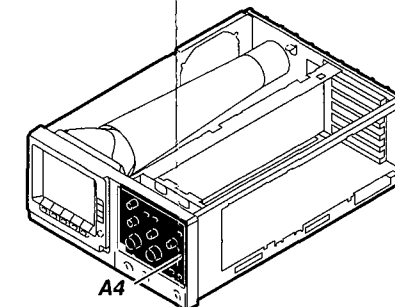
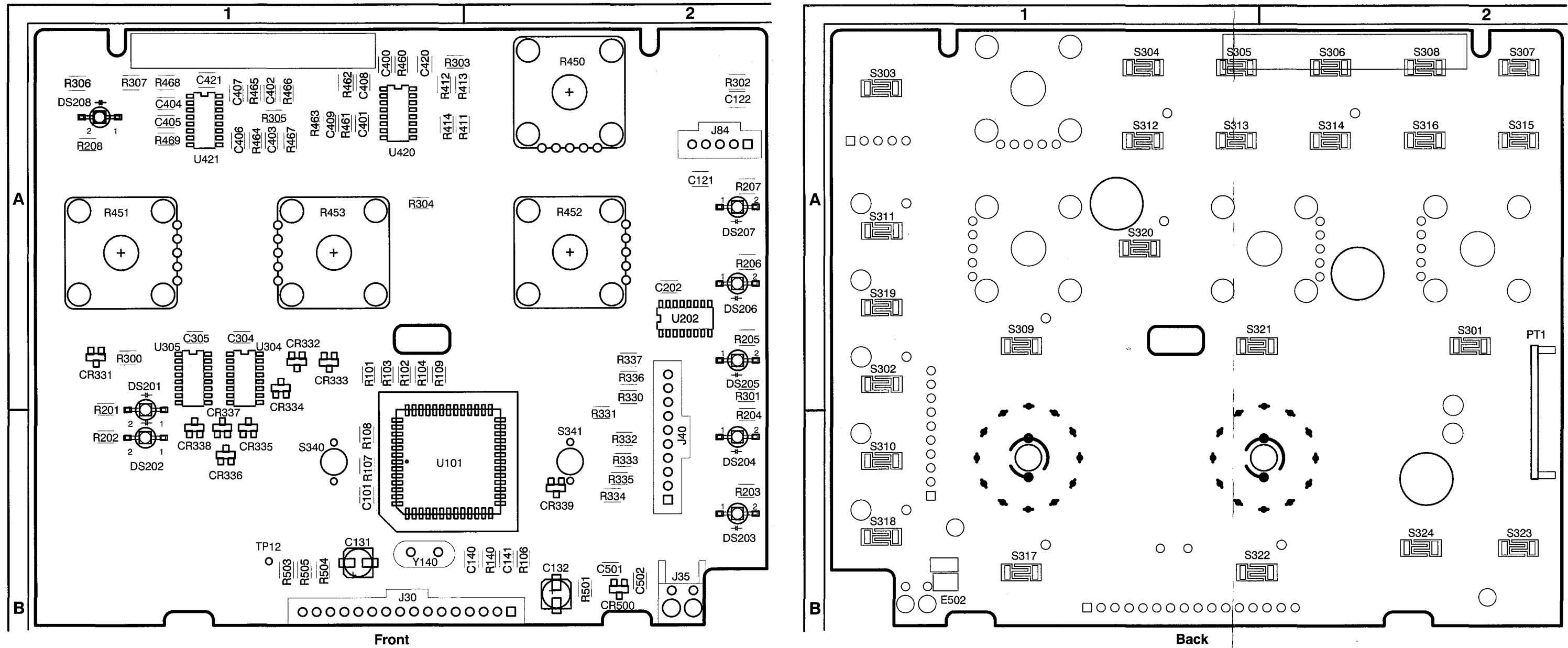

Figure 9-7: A5 Processor Board
TAS 475 — SN B010571 and Above
TAS 485 — SN B010321 and Above

A4 Front Panel Component Locator

CIRCUIT NUMBER	SCHEM NUMBER	SCHEM LOCATION	BOARD NUMBER	BOARD LOCATION	CIRCUIT NUMBER	SCHEM NUMBER	SCHEM LOCATION	BOARD NUMBER	BOARD LOCATION	CIRCUIT NUMBER	SCHEM NUMBER	SCHEM LOCATION	BOARD NUMBER	BOARD LOCATION	CIRCUIT NUMBER	SCHEM NUMBER	SCHEM LOCATION	BOARD NUMBER	BOARD LOCATION	CIRCUIT NUMBER	SCHEM NUMBER	SCHEM LOCATION	BOARD NUMBER	BOARD LOCATION	
C101	A4-1	3D	A4	1B	DS201	A4-6	3A	A4	1B	PT1	A4-5	3C	A4	2B	R333	A4-7	5C	A4	2B	S309*	A4-7	6A	A4	1A	
C121	A4-1	2D	A4	2A	DS202	A4-3	4A	A4	1B						R334	A4-4	5C	A4	2B	S310*	A4-4	5A	A4	1B	
C122	A4-1	2D	A4	2A	DS202	A4-6	4A	A4	1B	R101	A4-1	5B	A4	1B	R334	A4-7	5C	A4	2B	S310*	A4-7	5A	A4	1B	
C131	A4-1	1C	A4	1B	DS203	A4-3	4A	A4	2B	R102	A4-1	5B	A4	1B	R335	A4-4	5C	A4	2B	S311*	A4-4	5A	A4	1A	
C132	A4-1	2C	A4	2B	DS203	A4-6	4A	A4	2B	R103	A4-1	5B	A4	1B	R335	A4-7	5C	A4	2B	S311*	A4-7	5A	A4	1A	
C140	A4-1	3C	A4	2B	DS204	A4-3	4A	A4	2B	R104	A4-1	4B	A4	1B	R336	A4-4	5C	A4	2B	S312*	A4-4	4A	A4	1A	
C141	A4-1	3C	A4	2B	DS204	A4-6	4A	A4	2B	R106	A4-1	6C	A4	2B	R336	A4-7	5C	A4	2B	S312*	A4-7	4A	A4	1A	
C202	A4-4	2D	A4	2A	DS205	A4-3	5A	A4	2B	R107	A4-1	6C	A4	1B	R337	A4-4	5C	A4	2A	S313*	A4-4	6B	A4	1A	
C202	A4-7	2D	A4	2A	DS205	A4-6	5A	A4	2B	R108	A4-1	4C	A4	1B	R337	A4-7	5C	A4	2A	S313*	A4-7	6B	A4	1A	
C304	A4-4	3D	A4	1A	DS206	A4-3	5A	A4	2A	R109	A4-1	4B	A4	1B	R411	A4-2	4A	A4	1A	S314*	A4-4	5B	A4	2A	
C304	A4-7	3D	A4	1A	DS206	A4-6	5A	A4	2A	R140	A4-1	3C	A4	2B	R412	A4-2	4A	A4	1A	S314*	A4-7	5B	A4	2A	
C305	A4-4	3D	A4	1A	DS207	A4-3	5A	A4	2A	R201	A4-3	3A	A4	1B	R413	A4-2	5A	A4	2A	S315*	A4-4	5B	A4	2A	
C305	A4-7	3D	A4	1A	DS207	A4-6	6A	A4	2A	R201	A4-6	3A	A4	1B	R414	A4-2	5A	A4	1A	S315*	A4-7	5B	A4	2A	
C400	A4-2	2B	A4	1A	DS208	A4-3	6A	A4	1A	R202	A4-3	4A	A4	1B	R450	A4-2	2B	A4	2A	S316*	A4-4	4B	A4	2A	
C401	A4-2	2B	A4	1A	DS208	A4-6	6A	A4	1A	R202	A4-6	4A	A4	1B	R451	A4-2	2C	A4	1A	S316*	A4-7	4B	A4	2A	
C402	A4-2	3C	A4	1A						R203	A4-3	4A	A4	2B	R452	A4-2	3C	A4	2A	S317*	A4-4	6B	A4	1B	
C403	A4-2	3C	A4	1A	E502	A4-1	6C	A4	1B	R203	A4-6	4A	A4	2B	R453	A4-2	4C	A4	1A	S317*	A4-7	6B	A4	1B	
C404	A4-2	4C	A4	1A						R204	A4-3	4A	A4	2B	R460	A4-2	3B	A4	1A	S318*	A4-4	5B	A4	1B	
C405	A4-2	4C	A4	1A	J30A	A4-1	1C	A4	1B	R204	A4-6	4A	A4	2B	R461	A4-2	4B	A4	1A	S318*	A4-7	5B	A4	1B	
C406	A4-2	2C	A4	1A	J30B	A4-1	1C	A4	1B	R205	A4-3	5A	A4	2A	R462	A4-2	4B	A4	1A	S319*	A4-4	5B	A4	1A	
C407	A4-2	3C	A4	1A	J30C	A4-1	1C	A4	1B	R205	A4-6	5A	A4	2A	R463	A4-2	4B	A4	1A	S319*	A4-7	5B	A4	1A	
C408	A4-2	3B	A4	1A	J30D	A4-1	6B	A4	1B	R206	A4-3	5A	A4	2A	R464	A4-2	4B	A4	1A	S320*	A4-4	4B	A4	1A	
C409	A4-2	3B	A4	1A	J30E	A4-1	6C	A4	1B	R206	A4-6	5A	A4	2A	R465	A4-2	4B	A4	1A	S320*	A4-7	4B	A4	1A	
C420	A4-1	4D	A4	1A	J30F	A4-1	6C	A4	1B	R207	A4-3	5A	A4	2A	R466	A4-2	4B	A4	1A	S321*	A4-4	6B	A4	2A	
C421	A4-1	4D	A4	1A	J30G	A4-2	1A	A4	1B	R207	A4-6	6A	A4	2A	R467	A4-2	4B	A4	1A	S321*	A4-7	6B	A4	2A	
C501	A4-1	5C	A4	2B	J30H	A4-2	1A	A4	1B	R208	A4-3	6A	A4	1A	R468	A4-2	4B	A4	1A	S322*	A4-4	5B	A4	2B	
C502	A4-1	6C	A4	2B	J35	A4-1	6C	A4	2B	R208	A4-6	6A	A4	1A	R469	A4-2	4B	A4	1A	S322*	A4-7	5B	A4	2B	
CR331A	A4-4	2A	A4	1A	J40A	A4-1	6D	A4	2B	R300	A4-4	6A	A4	1A	R501	A4-1	5C	A4	2B	S323*	A4-4	5B	A4	2B	
CR331A	A4-7	2A	A4	1A	J40C	A4-4	6C	A4	2B	R300	A4-7	6A	A4	1A	R503	A4-1	4C	A4	1B	S323*	A4-7	5B	A4	2B	
CR332A	A4-4	2B	A4	1A	J40D	A4-4	6C	A4	2B	R301	A4-4	6A	A4	2B	R504	A4-1	4D	A4	1B	S324*	A4-4	4B	A4	2B	
CR332A	A4-7	2B	A4	1A	J40E	A4-4	6C	A4	2B	R301	A4-7	6A	A4	2B	R505	A4-1	4D	A4	1B	S324*	A4-7	4B	A4	2B	
CR333A	A4-4	2B	A4	1A	J40F	A4-4	6C	A4	2B	R302	A4-4	6A	A4	2A						S340*	A4-4	4C	A4	1B	
CR333A	A4-7	2B	A4	1A	J40G	A4-4	6C	A4	2B	R302	A4-7	6A	A4	2A	S301*	A4-4	6A	A4	2A	S340*	A4-7	4C	A4	1B	
CR333A	A4-4	3C	A4	1B	J40H	A4-4	6B	A4	2B	R303	A4-4	4A	A4	1A	S301*	A4-7	6A	A4	2A	S341*	A4-4	4C	A4	2B	
CR334A	A4-4	3C	A4	1B	J40I	A4-4	6C	A4	2B	R303	A4-7	4A	A4	1A	S302*	A4-4	5A	A4	1B	S341*	A4-7	4C	A4	2B	
CR334A	A4-7	3C	A4	1B	J40J	A4-4	6C	A4	2B	R304	A4-4	4A	A4	1A	S302*	A4-7	4A	A4	1A						
CR335A	A4-4	3C	A4	1B	J40C	A4-7	6C	A4	2B	R304	A4-7	4A	A4	1A	S303*	A4-4	5A	A4	1A	TP12	A4-1	4C	A4	1B	
CR335A	A4-7	3C	A4	1B	J40D	A4-7	6C	A4	2B	R305	A4-4	4A	A4	1A	S303*	A4-7	5A	A4	1A						
CR336A	A4-4	3C	A4	1B	J40E	A4-7	6C	A4	2B	R305	A4-7	4A	A4	1A	S304*	A4-4	4A	A4	1A	U101	A4-1	3B	A4	1B	
CR336A	A4-7	3C	A4	1B	J40F	A4-7	6C	A4	2B	R306	A4-4	4A	A4	1A	S304*	A4-7	4A	A4	1A	U202	A4-3	3A	A4	2A	
CR337A	A4-4	3C	A4	1B	J40G	A4-7	6C	A4	2B	R306	A4-7	4A	A4	1A	S305*	A4-4	4A	A4	1A	U202	A4-6	3A	A4	2A	
CR337A	A4-7	3C	A4	1B	J40H	A4-7	6B	A4	2B	R307	A4-4	4A	A4	1A	S305*	A4-7	4A	A4	1A	U304	A4-4	2B	A4	1A	
CR338A	A4-4	3C	A4	1B	J40I	A4-7	6C	A4	2B	R307	A4-7	4A	A4	1A	S306*	A4-4	3A	A4	2A	U304	A4-7	2B	A4	1A	
CR338A	A4-7	3C	A4	1B	J40J	A4-7	6C	A4	2B	R330	A4-4	4B	A4	2B	S306*	A4-7	3A	A4	2A	U305	A4-4	2D	A4	1A	
CR339A	A4-4	3D	A4	2B	J84A	A4-1	3D	A4	2A	R330	A4-7	4B	A4	2B	S307*	A4-4	3A	A4	2A	U305	A4-7	2D	A4	1A	
CR339A	A4-7	3D	A4	2B	J84C	A4-1	3D	A4	2A	R331	A4-4	4C	A4	2B	S307*	A4-7	3A	A4	2A	U420	A4-2	5A	A4	1A	
CR500A	A4-1	5C	A4	2B	J84E	A4-1	3D	A4	2A	R331	A4-7	4C	A4	2B	S308*	A4-4	2A	A4	2A	U421	A4-2	5B	A4	1A	
CR500B	A4-1	5C	A4	2B	J84B	A4-2	1A	A4	2A	R332	A4-4	4C	A4	2B	S308*	A4-7	2A	A4	2A						
DS201	A4-3	3A	A4	1B	J84D	A4-2	1A	A4	2A	R332	A4-7	4C	A4	2B	S309*	A4-4	6A	A4	1A	Y140	A4-1	3C	A4	1B	
										R333	A4-4	4C	A4	2B											

*Asterisks indicate components located on the back of the board.



389-1422-00
671-2220-00
Q9A-1422-00

COMPONENT NUMBER EXAMPLE

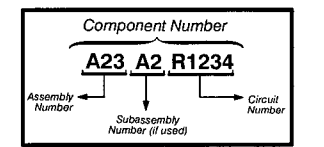

Chassis-mounted components have no Assembly Number prefix—see end of Replaceable Electrical Parts List.



STATIC SENSITIVE DEVICES

Figure 9-8: A4 Front Panel Board

A1 Analog Component Locator

CIRCUIT NUMBER	SCHEM NUMBER	SCHEM LOCATION	BOARD NUMBER	BOARD LOCATION	CIRCUIT NUMBER	SCHEM NUMBER	SCHEM LOCATION	BOARD NUMBER	BOARD LOCATION	CIRCUIT NUMBER	SCHEM NUMBER	SCHEM LOCATION	BOARD NUMBER	BOARD LOCATION	CIRCUIT NUMBER	SCHEM NUMBER	SCHEM LOCATION	BOARD NUMBER	BOARD LOCATION	CIRCUIT NUMBER	SCHEM NUMBER	SCHEM LOCATION	BOARD NUMBER	BOARD LOCATION
AT401	A1-1	4C	A1	1C	C431	A1-3	3D	A1	3B	J402	A1-1	1B	A1	1B	R417	A1-1	1C	A1	2C	U404C	A1-1	3C	A1	2C
AT402	A1-1	3A	A1	1B	C432	A1-3	2D	A1	2B	J405	A1-3	6A	A1	2B	R418	A1-1	1B	A1	2C	U404D	A1-1	4A	A1	2C
AT450	A1-2	3A	A1	1A	C434	A1-3	2B	A1	3C	J406	A1-3	6A	A1	2A	R419	A1-3	3C	A1	2A	U404E	A1-1	4D	A1	2C
AT451	A1-2	4C	A1	1B	C435	A1-3	3B	A1	3C	J450	A1-2	1B	A1	1A	R421	A1-1	2D	A1	2C	U404F	A1-1	4A	A1	2C
					C436	A1-3	3C	A1	2A	J451	A1-2	1C	A1	1B	R422	A1-3	6B	A1	2B	U404G	A1-1	1C	A1	2C
C401	A1-3	6B	A1	2B	C437	A1-1	2D	A1	2B						R423	A1-2	2D	A1	2A	U405	A1-3	4A	A1	2B
C402	A1-3	6C	A1	2B	C438	A1-3	4C	A1	3B	L401	A1-3	2D	A1	3A	R425	A1-3	3D	A1	3B	U406	A1-3	2B	A1	3B
C403	A1-3	6C	A1	3B	C450	A1-2	2D	A1	2A	L402	A1-3	1D	A1	2C	R426	A1-3	5C	A1	2A	U407	A1-3	3B	A1	2B
C404	A1-1	2C	A1	1C	C451	A1-2	2C	A1	1B	L403	A1-3	3D	A1	2C	R427	A1-3	2C	A1	2B	U450A	A1-2	5C	A1	2A
C405	A1-1	2B	A1	1B	C452	A1-2	2C	A1	2C	L404	A1-3	3D	A1	3A	R428	A1-3	3B	A1	3B	U450B	A1-2	5C	A1	2A
C407	A1-3	5D	A1	2B	C453	A1-2	2B	A1	1A	L405	A1-3	2D	A1	3A	R429	A1-3	2C	A1	2B	U450C	A1-2	3C	A1	2A
C408	A1-1	2C	A1	2C	C454	A1-2	2B	A1	2C	L406	A1-3	1D	A1	2A	R450	A1-2	1B	A1	2C	U450D	A1-2	4A	A1	2A
C409	A1-1	2B	A1	2C											R451	A1-2	1C	A1	2C	U450E	A1-2	5D	A1	2A
C410	A1-3	5C	A1	2A	CL401	A1-4	6A	A1	2A	Q401	A1-3	4C	A1	3B						U450F	A1-2	4A	A1	2A
C411	A1-3	5C	A1	2B						Q402	A1-3	4B	A1	2A	U403A	A1-1	5C	A1	2B	U450G	A1-2	1C	A1	2A
C417	A1-1	2D	A1	2B	E402	A1-4	5C	A1	2A	Q403	A1-3	4C	A1	2A	U403B	A1-1	5C	A1	2B	U451A	A1-2	5C	A1	2A
C423	A1-2	2D	A1	2A	E403	A1-4	6C	A1	2A						U403C	A1-1	3C	A1	2B	U451B	A1-2	5C	A1	2A
C425	A1-3	3D	A1	3B						R402	A1-3	2B	A1	3B	U403D	A1-1	4A	A1	2B	U451C	A1-2	3C	A1	2A
C426	A1-3	3D	A1	3A	J50	A1-3	1A	A1	2B	R403	A1-3	2B	A1	3B	U403E	A1-1	5D	A1	2B	U451D	A1-2	4A	A1	2A
C427	A1-3	4D	A1	2B	J66	A1-3	1C	A1	3B	R404	A1-3	3B	A1	3B	U403F	A1-1	4A	A1	2B	U451E	A1-2	4D	A1	2A
C428	A1-3	4D	A1	2C	J67	A1-3	1C	A1	3B	R413	A1-3	3B	A1	3B	U403G	A1-1	1C	A1	2B	U451F	A1-2	4A	A1	2A
C429	A1-3	3D	A1	2A	J68	A1-3	6A	A1	2A	R415	A1-3	3B	A1	2B	U404A	A1-1	5C	A1	2C	U451G	A1-2	1C	A1	2A
C430	A1-3	2D	A1	3A	J401	A1-1	1C	A1	1B	R416	A1-3	2B	A1	3C	U404B	A1-1	5C	A1	2C					

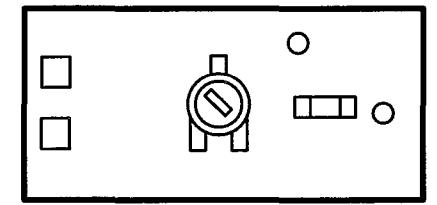
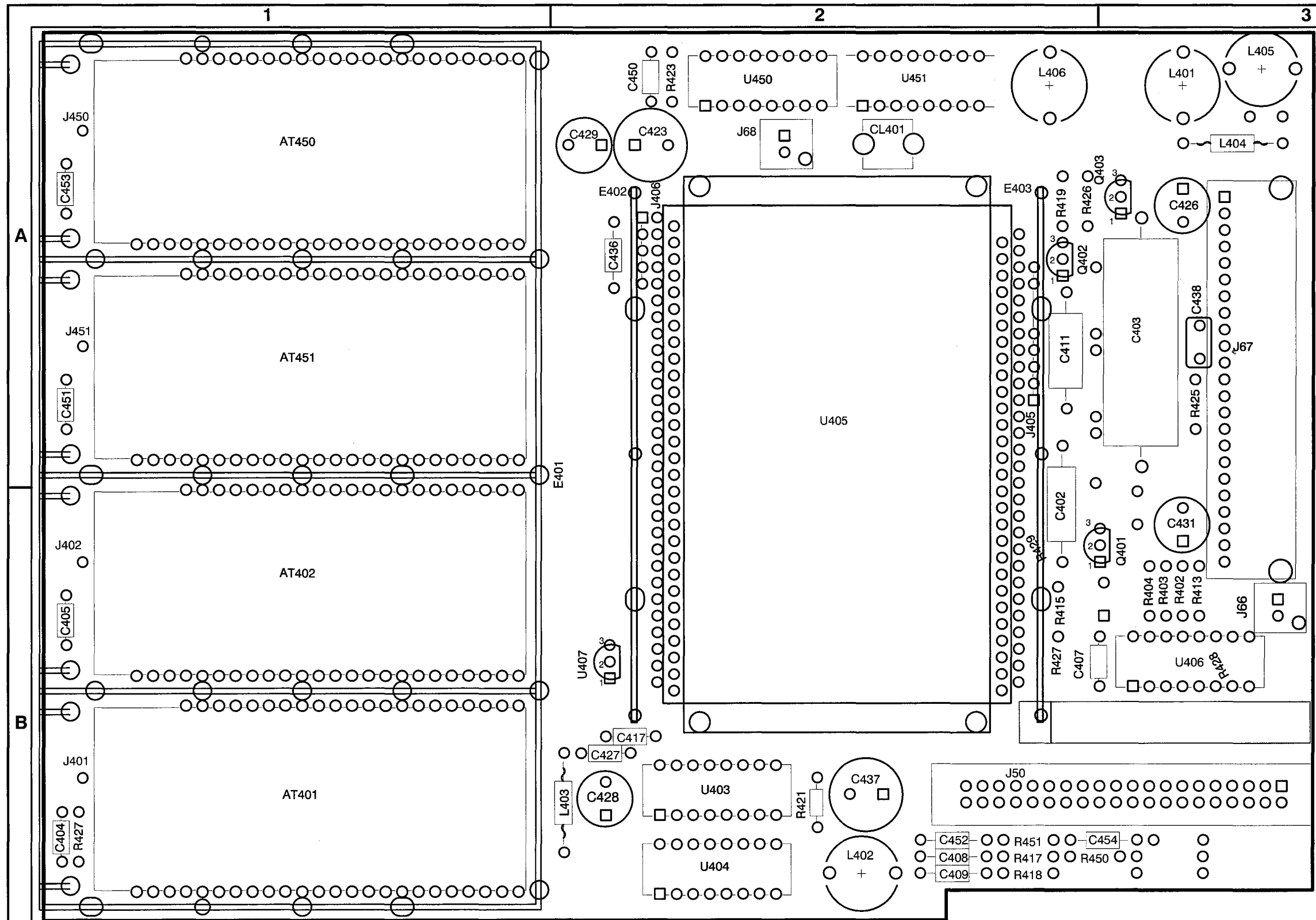

A10 Termination Board
TAS 485 Only

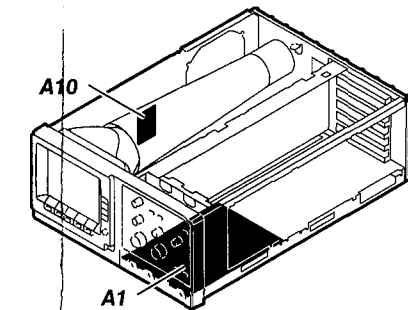

671-2646-01
389-1508-00
Q9D-1508-00

COMPONENT NUMBER EXAMPLE

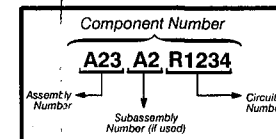

Chassis-mounted components have no Assembly Number prefix—see end of Replaceable Electrical Parts List.

STATIC SENSITIVE DEVICES

Figure 9-9: A1 Analog Board and A10 Termination Board

A3 Display Driver Component Locator (TAS 475)

CIRCUIT NUMBER	SCHEM NUMBER	SCHEM LOCATION	BOARD NUMBER	BOARD LOCATION	CIRCUIT NUMBER	SCHEM NUMBER	SCHEM LOCATION	BOARD NUMBER	BOARD LOCATION	CIRCUIT NUMBER	SCHEM NUMBER	SCHEM LOCATION	BOARD NUMBER	BOARD LOCATION	CIRCUIT NUMBER	SCHEM NUMBER	SCHEM LOCATION	BOARD NUMBER	BOARD LOCATION	CIRCUIT NUMBER	SCHEM NUMBER	SCHEM LOCATION	BOARD NUMBER	BOARD LOCATION
C102	A3-1	5B	A3	3A	C316	A3-3	4A	A3	1B	Q206	A3-2	4C	A3	2A	R150	A3-1	3D	A3	2B	R301	A3-3	2B	A3	2B
C104	A3-1	4A	A3	3A	C317	A3-3	3B	A3	1C	Q207	A3-2	2A	A3	2B	R151	A3-1	4B	A3	3A	R303	A3-3	4A	A3	1B
C105	A3-1	3C	A3	2A	C319	A3-3	2C	A3	2C	Q208	A3-2	4A	A3	2A	R152	A3-1	4C	A3	3B	R304	A3-3	3B	A3	1A
C106	A3-1	3D	A3	3A	C320	A3-3	6B	A3	1B	Q209	A3-2	4C	A3	2A	R153	A3-1	3B	A3	3B	R305	A3-3	4A	A3	1B
C107	A3-1	3D	A3	2B	C321	A3-3	1A	A3	2B	Q210	A3-2	3C	A3	2B	R154	A3-1	3B	A3	2A	R306	A3-3	4B	A3	2C
C108	A3-1	3D	A3	2B	C322	A3-3	1D	A3	3C	Q211	A3-2	3C	A3	2B	R155	A3-1	2C	A3	3B	R307	A3-3	5A	A3	1B
C109	A3-1	5A	A3	3A	C323	A3-3	1D	A3	3C	Q212	A3-2	3B	A3	2B	R156	A3-1	2C	A3	2C	R308	A3-3	5D	A3	1A
C110	A3-1	5B	A3	3A						Q301	A3-3	3A	A3	2B	R157	A3-1	2D	A3	2B	R309	A3-3	5D	A3	1A
C111	A3-1	3A	A3	3B	CL1	A3-4	4D	A3	2B	Q302	A3-3	3B	A3	2B	R201	A3-2	4D	A3	2B	R310	A3-3	4D	A3	1A
C112	A3-1	2A	A3	2B						Q303	A3-3	3B	A3	2B	R202	A3-2	5D	A3	2A	R311	A3-3	4D	A3	1A
C113	A3-1	4B	A3	3A	CR100	A3-1	2C	A3	2B	Q304	A3-3	3B	A3	2C	R203	A3-2	2C	A3	2B	R312	A3-3	3A	A3	1B
C116	A3-1	3B	A3	3B	CR101	A3-1	3D	A3	3B	Q307	A3-3	2B	A3	2B	R204	A3-2	2A	A3	2B	R313	A3-3	3B	A3	1B
C117	A3-1	2B	A3	2B	CR102	A3-1	2D	A3	3B	Q308	A3-3	4A	A3	1A	R205	A3-2	2C	A3	2B	R314	A3-3	3B	A3	2B
C118	A3-1	3A	A3	3B	CR201	A3-2	3B	A3	2B	Q360	A3-3	5D	A3	1B	R206	A3-2	2C	A3	2B	R315	A3-3	3B	A3	1B
C119	A3-1	3B	A3	3B	CR202	A3-2	3C	A3	2B	Q361	A3-3	5D	A3	1B	R207	A3-2	2C	A3	2B	R316	A3-3	1B	A3	2B
C120	A3-1	3A	A3	2B	CR301	A3-3	3B	A3	2C						R208	A3-2	3A	A3	2B	R317	A3-3	4A	A3	1A
C121	A3-1	2A	A3	2B	CR302	A3-3	4A	A3	1C	R101	A3-1	5A	A3	3A	R209	A3-2	3C	A3	2B	R318	A3-3	2B	A3	2C
C122	A3-1	2A	A3	3B	CR303	A3-3	5A	A3	1B	R102	A3-1	5B	A3	3A	R210	A3-2	4D	A3	2A	R321	A3-3	3A	A3	1A
C123	A3-1	5A	A3	3A	CR304	A3-3	4A	A3	1B	R103	A3-1	4C	A3	2A	R211	A3-2	4A	A3	2A	R322	A3-3	4D	A3	1A
C124	A3-1	4C	A3	3A	CR305	A3-3	3C	A3	2C	R104	A3-1	4C	A3	3A	R212	A3-2	4B	A3	2A	R323	A3-3	4D	A3	1A
C125	A3-1	1B	A3	2B	CR306	A3-3	5A	A3	1B	R105	A3-1	4B	A3	3B	R213	A3-2	4C	A3	1A	R324	A3-3	2B	A3	2C
C126	A3-1	1B	A3	2B	CR307	A3-3	3B	A3	1B	R106	A3-1	6A	A3	3A	R214	A3-2	2B	A3	2B	R325	A3-3	4A	A3	1B
C128	A3-1	2C	A3	2B	CR308	A3-3	3A	A3	1B	R107	A3-1	6B	A3	3A	R215	A3-2	2B	A3	2B	R326	A3-3	5B	A3	1B
C129	A3-1	3C	A3	2B						R108	A3-1	5A	A3	3A	R216	A3-2	2B	A3	2B	R329	A3-3	5A	A3	1B
C130	A3-1	5B	A3	2A	DS301	A3-3	5A	A3	1B	R109	A3-1	5B	A3	3A	R217	A3-2	3A	A3	2B	R330	A3-3	2A	A3	2B
C131	A3-1	6B	A3	3A	DS302	A3-3	5A	A3	1B	R111	A3-1	3B	A3	3B	R218	A3-2	3C	A3	2A	R331	A3-3	2A	A3	2B
C132	A3-1	6A	A3	3A						R112	A3-1	4C	A3	2A	R219	A3-2	5D	A3	2A	R332	A3-3	3A	A3	2B
C201	A3-2	4C	A3	1A	J69	A3-1	1A	A3	2B	R113	A3-1	2B	A3	2B	R220	A3-2	4B	A3	2A	R333	A3-3	3A	A3	2B
C203	A3-2	4A	A3	2A	J70	A3-1	1C	A3	2C	R114	A3-1	2B	A3	2B	R221	A3-2	4B	A3	2A	R350	A3-3	2A	A3	2B
C204	A3-2	4B	A3	2A	J71	A3-3	1C	A3	1B	R115	A3-1	4B	A3	3B	R222	A3-2	2B	A3	2B	R351	A3-3	4A	A3	1C
C205	A3-2	4B	A3	2A	J72	A3-3	6D	A3	1A	R116	A3-1	1B	A3	2B	R223	A3-2	3C	A3	2B	R352	A3-3	1A	A3	2B
C206	A3-2	3B	A3	2B	J73	A3-3	6B	A3	1B	R117	A3-1	1B	A3	2B	R224	A3-2	3A	A3	2A	R353	A3-3	1B	A3	2C
C207	A3-2	4C	A3	2A	J74	A3-2	6B	A3	2A	R120	A3-1	1B	A3	2B	R225	A3-2	4A	A3	2A	R360	A3-3	5B	A3	1B
C208	A3-2	3B	A3	2B	J75	A3-1	6A	A3	3A	R121	A3-1	1B	A3	2B	R226	A3-2	5B	A3	2A	R361	A3-3	5B	A3	1B
C209	A3-2	3C	A3	2B	J80	A3-3	1D	A3	3B	R122	A3-1	5A	A3	3A	R227	A3-2	4C	A3	2A	R362	A3-3	5B	A3	1B
C210	A3-2	2B	A3	2B						R123	A3-1	5B	A3	2A	R228	A3-2	4C	A3	2A	R363	A3-3	5B	A3	1B
C211	A3-2	1C	A3	2A	L101	A3-1	5A	A3	3A	R124	A3-1	6A	A3	3A	R229	A3-2	3B	A3	2B	R364	A3-3	5C	A3	1B
C213	A3-2	3D	A3	2A	L102	A3-1	5B	A3	2A	R125	A3-1	3A	A3	3B	R230	A3-2	3D	A3	2B	R365	A3-3	5D	A3	1B
C214	A3-2	4D	A3	2B	L103	A3-1	4A	A3	3A	R126	A3-1	2A	A3	2B	R231	A3-2	2B	A3	2B	R366	A3-3	5D	A3	2B
C216	A3-2	3A	A3	2A	L104	A3-1	2A	A3	3B	R127	A3-1	2A	A3	3B	R232	A3-2	2C	A3	2B	R367	A3-3	5C	A3	1B
C217	A3-2	3D	A3	1B	L105	A3-1	3A	A3	3B	R128	A3-1	3A	A3	3B	R233	A3-2	3A	A3	2A	R368	A3-3	5B	A3	1B
C218	A3-2	3A	A3	2A	L106	A3-1	3A	A3	3B	R129	A3-1	4A	A3	3B	R234	A3-2	3A	A3	2A	R369	A3-3	5C	A3	1B
C219	A3-2	1D	A3	2B	L107	A3-1	3B	A3	3B	R130	A3-1	3B	A3	3B	R235	A3-2	4A	A3	2A	R370	A3-3	6C	A3	1B
C221	A3-2	1D	A3	2B	L108	A3-1	3B	A3	3B	R131	A3-1	2B	A3	2B	R236	A3-2	4A	A3	2A	R371	A3-3	2D	A3	3C
C222	A3-2	3C	A3	2B	L109	A3-1	2A	A3	2B	R132	A3-1	2B	A3	3B	R237	A3-2	4C	A3	2A					
C301	A3-3	2B	A3	2B	L110	A3-1	2B	A3	3B	R133	A3-1	3A	A3	3B	R238	A3-2	4C	A3	2A	U101	A3-1	4A	A3	3B
C302	A3-3	3A	A3	2B	L111	A3-1	4A	A3	3B	R134	A3-1	3A	A3	3B	R239	A3-2	3D	A3	2A	U102A	A3-1	1B	A3	2B
C303	A3-3	3B	A3	2C	L112	A3-1	4B	A3	3B	R135	A3-1	4A	A3	3B	R240	A3-2	3D	A3	2A	U102B	A3-1	1B	A3	2B
C304	A3-3	4A	A3	1A	L113	A3-1	4A	A3	3B	R138	A3-1	5A	A3	3A	R241	A3-2	4D	A3	2A	U201A	A3-2	2D	A3	2B
C305	A3-3	4D	A3	1A	L300	A3-3	1D	A3	3B	R139	A3-1	3A	A3	3B	R242	A3-2	4A	A3	2A	U201B	A3-2	2D	A3	2B
C306	A3-3	5D	A3	1A						R140	A3-1	2A	A3	2B	R244	A3-2	1C	A3	2A					
C308	A3-3	2C	A3	2C	Q101	A3-1	5B	A3	2A	R141	A3-1	2A	A3	3B	R245	A3-2	3A	A3	2B	VR201	A3-2	3B	A3	2B
C309	A3-3	3B	A3	2B	Q102	A3-1	5A	A3	3A	R142	A3-1	5B	A3	2A	R246	A3-2	1C	A3	2B	VR360	A3-3	5C	A3	1B
C310	A3-3	5D	A3	1A	Q201	A3-2	2B	A3	2B	R144	A3-1	2A	A3	3B	R255	A3-2	1D	A3	3B	VR361	A3-3	5C	A3	1B
C311	A3-3	5B	A3	1B	Q202	A3-2	2C	A3	2B	R145	A3-1	4A	A3	3B	R256	A3-2	3C	A3	2B					
C312	A3-3	4A	A3	1B	Q203	A3-2	2C	A3	1B	R147	A3-1	4C	A3	3B	R257	A3-2	3C	A3	2B	W66	A3-1	1D	A3	3B
C313	A3-3	4A	A3	1C	Q204	A3-2	3B	A3	2B	R148	A3-1	4C	A3	2B	R258	A3-2	4C	A3	2A	W100	A3-1	5B	A3	3B
C314	A3-3	5B	A3	1B	Q205	A3-2	4B	A3	2A	R149	A3-1	3D	A3	3B	R259	A3-2	4B	A3	2A	W300	A3-3	1B	A3	2B
C315	A3-3	5B	A3	1B																				

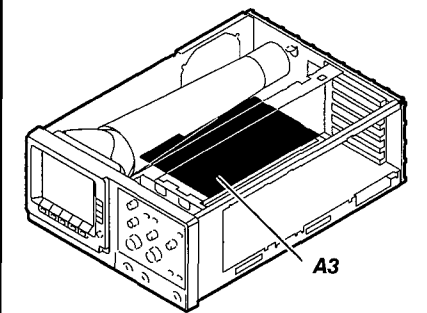
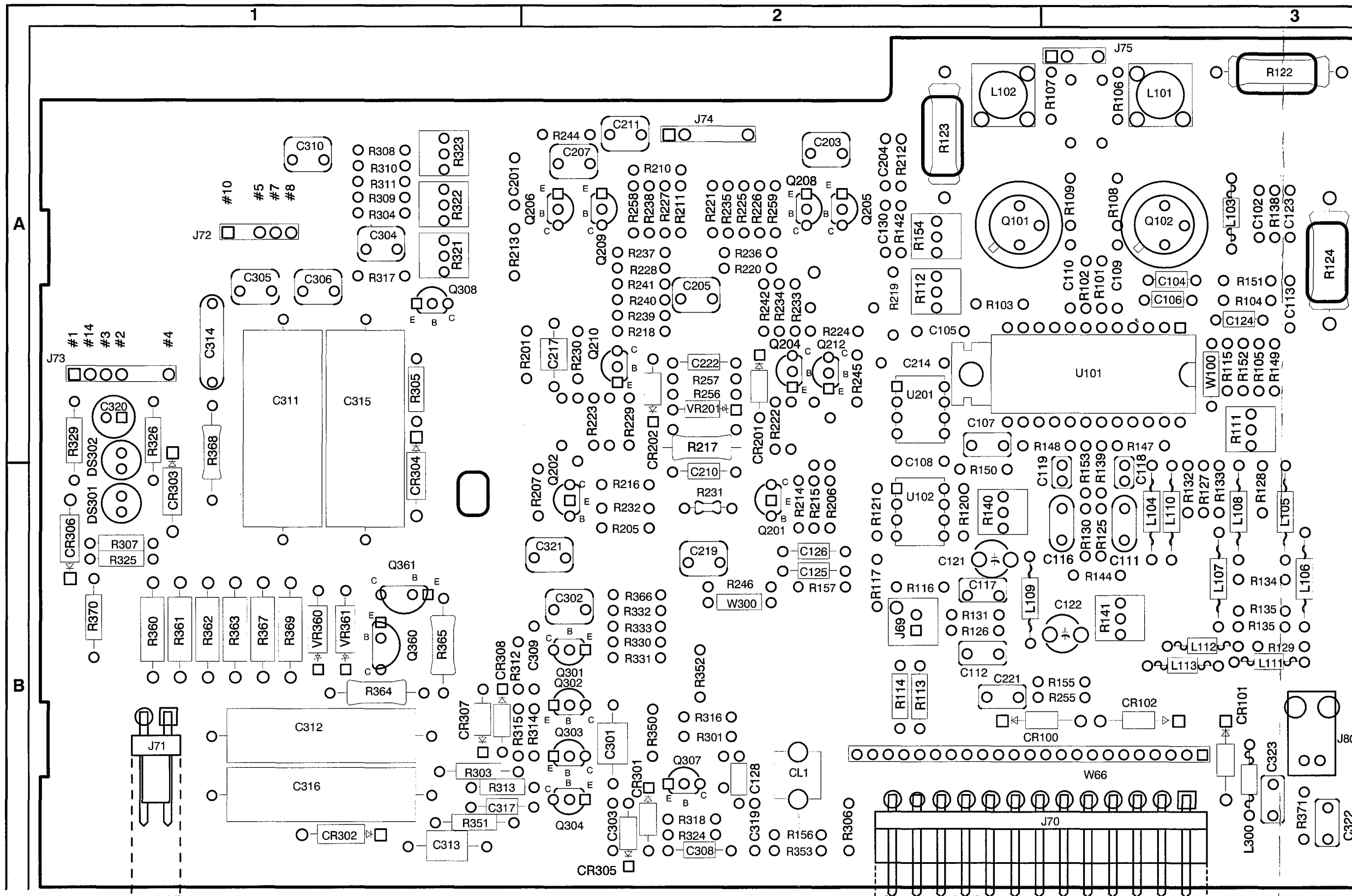

671-2904-xx
389-1222-00
QED-1222-00

COMPONENT NUMBER EXAMPLE

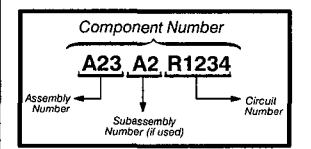

Chassis-mounted components have no Assembly Number prefix—see end of Replaceable Electrical Parts List.



Figure 9-10: A3 Display Driver Board (TAS 475)

A3 Display Driver Component Locator (TAS 485)

CIRCUIT NUMBER	SCHEM NUMBER	SCHEM LOCATION	BOARD NUMBER	BOARD LOCATION	CIRCUIT NUMBER	SCHEM NUMBER	SCHEM LOCATION	BOARD NUMBER	BOARD LOCATION	CIRCUIT NUMBER	SCHEM NUMBER	SCHEM LOCATION	BOARD NUMBER	BOARD LOCATION	CIRCUIT NUMBER	SCHEM NUMBER	SCHEM LOCATION	BOARD NUMBER	BOARD LOCATION	CIRCUIT NUMBER	SCHEM NUMBER	SCHEM LOCATION	BOARD NUMBER	BOARD LOCATION
C102	A3-1	3B	A3	3B	C325	A3-3	3D	A3	1B	Q206	A3-2	4C	A3	3A	R210	A3-2	5D	A3	3A	R313	A3-3	1C	A3	2B
C104	A3-1	3C	A3	2B	C333	A3-3	3C	A3	1B	Q208	A3-2	5A	A3	3A	R211	A3-2	5A	A3	3A	R314	A3-3	4D	A3	1B
C105	A3-1	3C	A3	2B	C334	A3-3	1A	A3	1A	Q209	A3-2	5C	A3	3A	R212	A3-2	4B	A3	3A	R315	A3-3	1C	A3	2B
C106	A3-1	3D	A3	3B	C335	A3-3	2A	A3	2B	Q210	A3-2	4C	A3	2A	R214	A3-2	3B	A3	3A	R316	A3-3	1C	A3	2B
C107	A3-1	3D	A3	3B						Q211	A3-2	4A	A3	3A	R215	A3-2	3A	A3	3B	R317	A3-3	4A	A3	1A
C108	A3-1	3D	A3	3B	CR100	A3-1	2C	A3	3B	Q212	A3-2	5A	A3	3A	R216	A3-2	3C	A3	3B	R320	A3-3	3C	A3	1B
C109	A3-1	6A	A3	2A	CR101	A3-1	3D	A3	3B	Q213	A3-2	5C	A3	3A	R217	A3-2	4A	A3	3A	R321	A3-3	3A	A3	1A
C113	A3-1	5C	A3	2A	CR102	A3-1	2D	A3	3B	Q214	A3-2	4C	A3	2A	R218	A3-2	4C	A3	3A	R322	A3-3	4D	A3	1A
C121	A3-1	3B	A3	2B	CR201	A3-2	4B	A3	3A	Q215	A3-2	2B	A3	3B	R219	A3-2	5D	A3	3A	R323	A3-3	3D	A3	1A
C122	A3-1	3B	A3	2B	CR202	A3-2	3C	A3	2A	Q216	A3-2	2C	A3	3B	R220	A3-2	5B	A3	3A	R324	A3-3	2A	A3	2B
C124	A3-1	5C	A3	2B	CR301	A3-3	2B	A3	2B	Q217	A3-2	4B	A3	3A	R221	A3-2	5B	A3	3A	R325	A3-3	4A	A3	1B
C125	A3-1	1B	A3	2B	CR302	A3-3	4A	A3	1B	Q218	A3-2	4C	A3	2A	R224	A3-2	3A	A3	3A	R326	A3-3	5B	A3	1B
C126	A3-1	1B	A3	2B	CR303	A3-3	5A	A3	1B	Q301	A3-3	3A	A3	1B	R225	A3-2	5A	A3	3A	R327	A3-3	3C	A3	1B
C128	A3-1	2C	A3	2B	CR304	A3-3	4A	A3	1B	Q303	A3-3	1C	A3	2B	R226	A3-2	5B	A3	3A	R328	A3-3	2C	A3	1B
C129	A3-1	3C	A3	2B	CR305	A3-3	3C	A3	1B	Q304	A3-3	3B	A3	1B	R227	A3-2	5C	A3	3A	R329	A3-3	5A	A3	1B
C203	A3-2	4A	A3	3A	CR306	A3-3	5A	A3	1B	Q305	A3-3	1C	A3	2B	R228	A3-2	5C	A3	3A	R330	A3-3	2A	A3	2B
C204	A3-2	4B	A3	3A	CR307	A3-3	3B	A3	1B	Q306	A3-3	3C	A3	1B	R229	A3-2	4B	A3	2A	R331	A3-3	2A	A3	2B
C205	A3-2	5B	A3	3A	CR308	A3-3	3A	A3	1B	Q307	A3-3	2B	A3	2B	R230	A3-2	3D	A3	2A	R332	A3-3	2C	A3	1B
C206	A3-2	4B	A3	3A	CR309	A3-3	3C	A3	1B	Q308	A3-3	4A	A3	1A	R231	A3-2	2B	A3	3B	R333	A3-3	3A	A3	2B
C207	A3-2	4C	A3	3A	CR310	A3-3	4C	A3	1A	Q309	A3-3	3C	A3	1B	R232	A3-2	2C	A3	3B	R335	A3-3	3C	A3	1B
C210	A3-2	3B	A3	3A	CR311	A3-3	4C	A3	1A	Q310	A3-3	2C	A3	2B	R234	A3-2	4A	A3	3A	R336	A3-3	4C	A3	1B
C211	A3-2	1C	A3	2B	CR312	A3-3	3A	A3	2B	Q361	A3-3	3D	A3	1B	R235	A3-2	5A	A3	3A	R350	A3-3	2A	A3	2B
C213	A3-2	4D	A3	2A						R236	A3-2	5A	A3	3A	R351	A3-3	4A	A3	3A	R351	A3-3	4A	A3	1B
C214	A3-2	5D	A3	3A	DS301	A3-3	5A	A3	1B	R101	A3-1	5A	A3	2A	R237	A3-2	5C	A3	3A	R352	A3-3	1A	A3	2B
C218	A3-2	4A	A3	3A	DS302	A3-3	5A	A3	1B	R102	A3-1	5A	A3	2A	R238	A3-2	5C	A3	3A	R360	A3-3	5B	A3	1B
C219	A3-2	1D	A3	3B						R103	A3-1	5B	A3	2A	R239	A3-2	4D	A3	2A	R361	A3-3	5B	A3	1B
C221	A3-2	1D	A3	3B	J69	A3-1	1A	A3	2B	R104	A3-1	5C	A3	2B	R240	A3-2	4D	A3	2A	R364	A3-3	4D	A3	1B
C222	A3-2	4C	A3	3A	J70	A3-1	1C	A3	3B	R105	A3-1	5C	A3	2A	R241	A3-2	4D	A3	2A	R365	A3-3	4D	A3	1B
C224	A3-2	2B	A3	3B	J71	A3-3	1B	A3	1B	R111	A3-1	5C	A3	2A	R242	A3-2	4A	A3	3A	R366	A3-3	5D	A3	1B
C226	A3-2	2B	A3	3B	J72	A3-3	6D	A3	1A	R112	A3-1	5B	A3	2A	R244	A3-2	1C	A3	2B	R367	A3-3	1C	A3	2B
C227	A3-2	3A	A3	3A	J73	A3-3	6B	A3	1A	R113	A3-1	2B	A3	2B	R245	A3-2	4A	A3	3A	R368	A3-3	5B	A3	1B
C256	A3-2	3C	A3	2A	J74	A3-2	6B	A3	3A	R114	A3-1	2B	A3	2B	R246	A3-2	1D	A3	2B	R370	A3-3	6C	A3	1B
C257	A3-2	2C	A3	3A	J77	A3-1	3B	A3	3B	R116	A3-1	1B	A3	2B	R255	A3-2	1D	A3	3B	R371	A3-3	4D	A3	3B
C258	A3-2	4D	A3	2A	J80	A3-3	1D	A3	3B	R117	A3-1	1B	A3	2B	R257	A3-2	3C	A3	2A	R372	A3-3	5D	A3	1A
C301	A3-3	2A	A3	2B						R120	A3-1	1B	A3	2B	R258	A3-2	4B	A3	3A	R373	A3-3	5D	A3	1A
C302	A3-3	3A	A3	1B	L101	A3-1	3C	A3	2B	R121	A3-1	1B	A3	2B	R259	A3-2	4C	A3	3A	R374	A3-3	2D	A3	2B
C303	A3-3	3B	A3	2B	L102	A3-1	3D	A3	3B	R129	A3-1	4B	A3	1B	R260	A3-2	4C	A3	3A					
C304	A3-3	4A	A3	1A	L103	A3-1	3D	A3	3B	R134	A3-1	5B	A3	2B	R262	A3-2	2B	A3	3B	U101	A3-1	5A	A3	2A
C305	A3-3	3D	A3	1A	L105	A3-1	5A	A3	2B	R135	A3-1	4B	A3	2B	R263	A3-2	2C	A3	3B	U102A	A3-1	1B	A3	2B
C306	A3-3	4D	A3	1A	L106	A3-1	4A	A3	2B	R136	A3-1	3A	A3	2B	R264	A3-2	2B	A3	3B	U102B	A3-1	1B	A3	2B
C307	A3-3	3B	A3	2B	L107	A3-1	4B	A3	2B	R137	A3-1	3B	A3	2B	R265	A3-2	4A	A3	3A	U201A	A3-2	3D	A3	3A
C309	A3-3	3C	A3	1B	L108	A3-1	5B	A3	2B	R138	A3-1	2B	A3	2B	R266	A3-2	3A	A3	3B	U201B	A3-2	3D	A3	3A
C310	A3-3	5D	A3	1A	L109	A3-1	4A	A3	2B	R140	A3-1	3B	A3	2B	R267	A3-2	2B	A3	3B					
C311	A3-3	5B	A3	1A	L110	A3-1	3A	A3	2B	R141	A3-1	3B	A3	2B	R268	A3-2	2C	A3	3B	VR201	A3-2	4B	A3	2A
C312	A3-3	4A	A3	1B	L111	A3-1	4A	A3	2B	R142	A3-1	5B	A3	2B	R301	A3-3	2A	A3	2B	VR360	A3-3	3B	A3	2B
C313	A3-3	4A	A3	1B	L112	A3-1	4B	A3	2B	R143	A3-1	6A	A3	2A	R302	A3-3	3B	A3	2B	VR361	A3-3	5C	A3	1B
C314	A3-3	3C	A3	1B	L113	A3-1	6A	A3	2A	R144	A3-1	6B	A3	2A	R303	A3-3	4A	A3	1B	VR362	A3-3	5C	A3	1B
C315	A3-3	5B	A3	1B	L114	A3-1	6B	A3	2A	R146	A3-1	4B	A3	2B	R304	A3-3	3B	A3	1A	VR363	A3-3	5C	A3	1B
C316	A3-3	4A	A3	1B	L300	A3-3	1D	A3	2B	R154	A3-1	4B	A3	2A	R305	A3-3	4A	A3	1B	VR364	A3-3	5C	A3	1B
C317	A3-3	3C	A3	1B						R156	A3-1	1C	A3	2B	R306	A3-3	4B	A3	2B	VR365	A3-3	5C	A3	1B
C318	A3-3	4C	A3	1A	Q101	A3-1	5A	A3	2B	R157	A3-1	1D	A3	2B	R307	A3-3	5A	A3	1B	VR366	A3-3	5C	A3	1B
C320	A3-3	6B	A3	1B	Q102	A3-1	5A	A3	2B	R201	A3-2	5D	A3	3A	R308	A3-3	4D	A3	1A	VR367	A3-3	5B	A3	1B
C321	A3-3	1A	A3	2B	Q201	A3-2	3B	A3	3B	R202	A3-2	5D	A3	3A	R309	A3-3	4D	A3	1A					
C322	A3-3	1D	A3	3B	Q202	A3-2	3C	A3	3B	R205	A3-2	2C	A3	3B	R310	A3-3	3D	A3	1A	W66	A3-1	1D	A3	3B
C323	A3-3	1D	A3	3B	Q204	A3-2	4B	A3	3A	R206	A3-2	2C	A3	3B	R311	A3-3	4D	A3	1A	W75	A3-1	6A	A3	2A
C324	A3-3	5D	A3	1A	Q205	A3-2	4B	A3	3A	R207	A3-2	3C	A3	3B	R312	A3-3	1C	A3	2B	W76	A3-1	6B	A3	2A

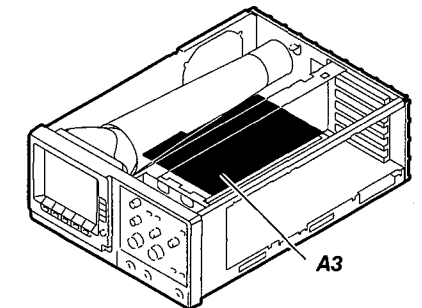
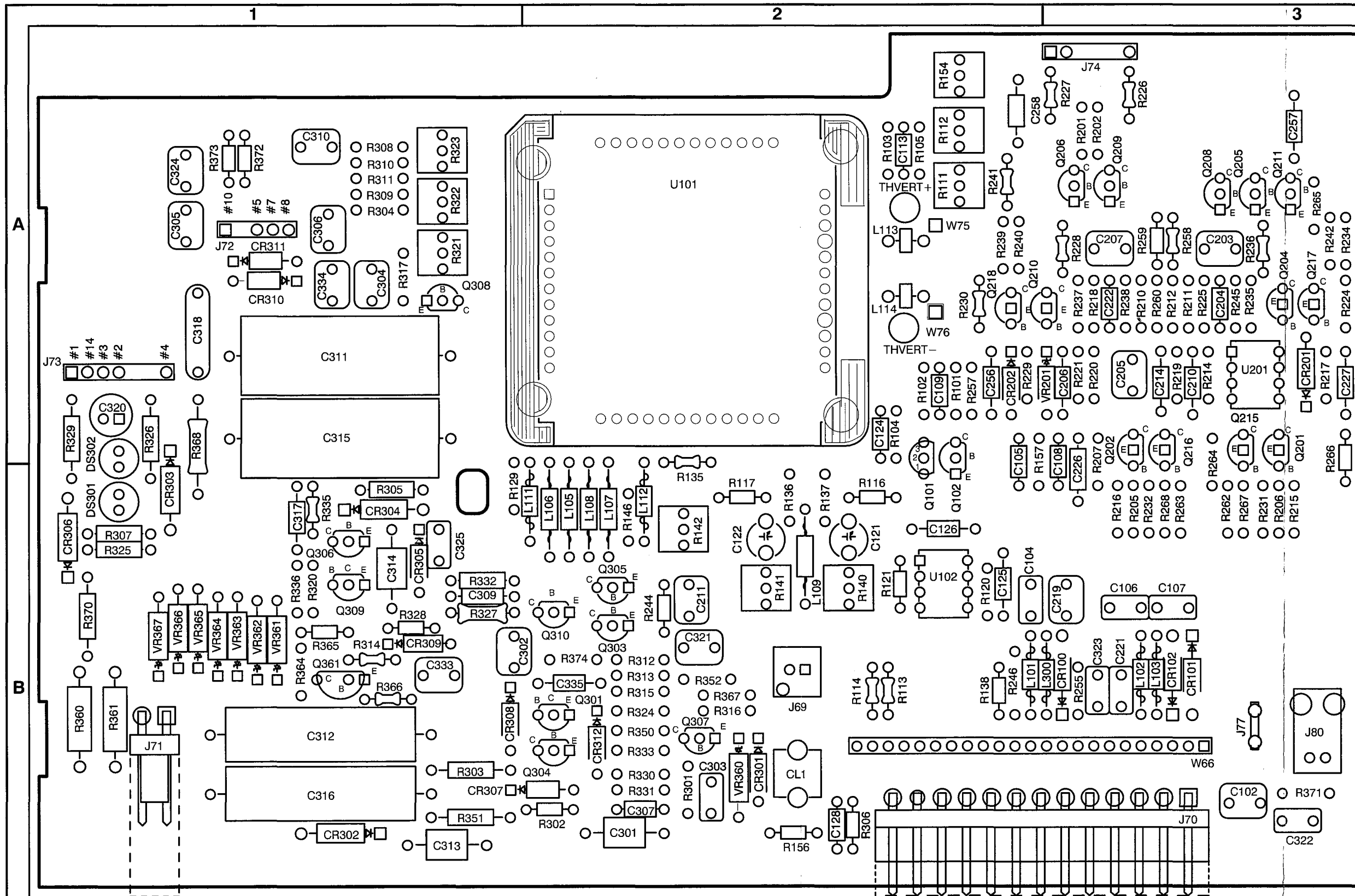

389-1507-01
671-2647-02
Q9A-1507-01

COMPONENT NUMBER EXAMPLE

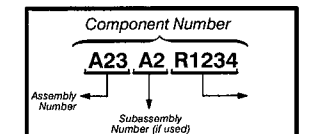

Chassis-mounted components have no Assembly Number prefix—see end of Replacable Electrical Parts List.

STATIC SENSITIVE DEVICES

Figure 9-11: A3 Display Driver Board (TAS 485)

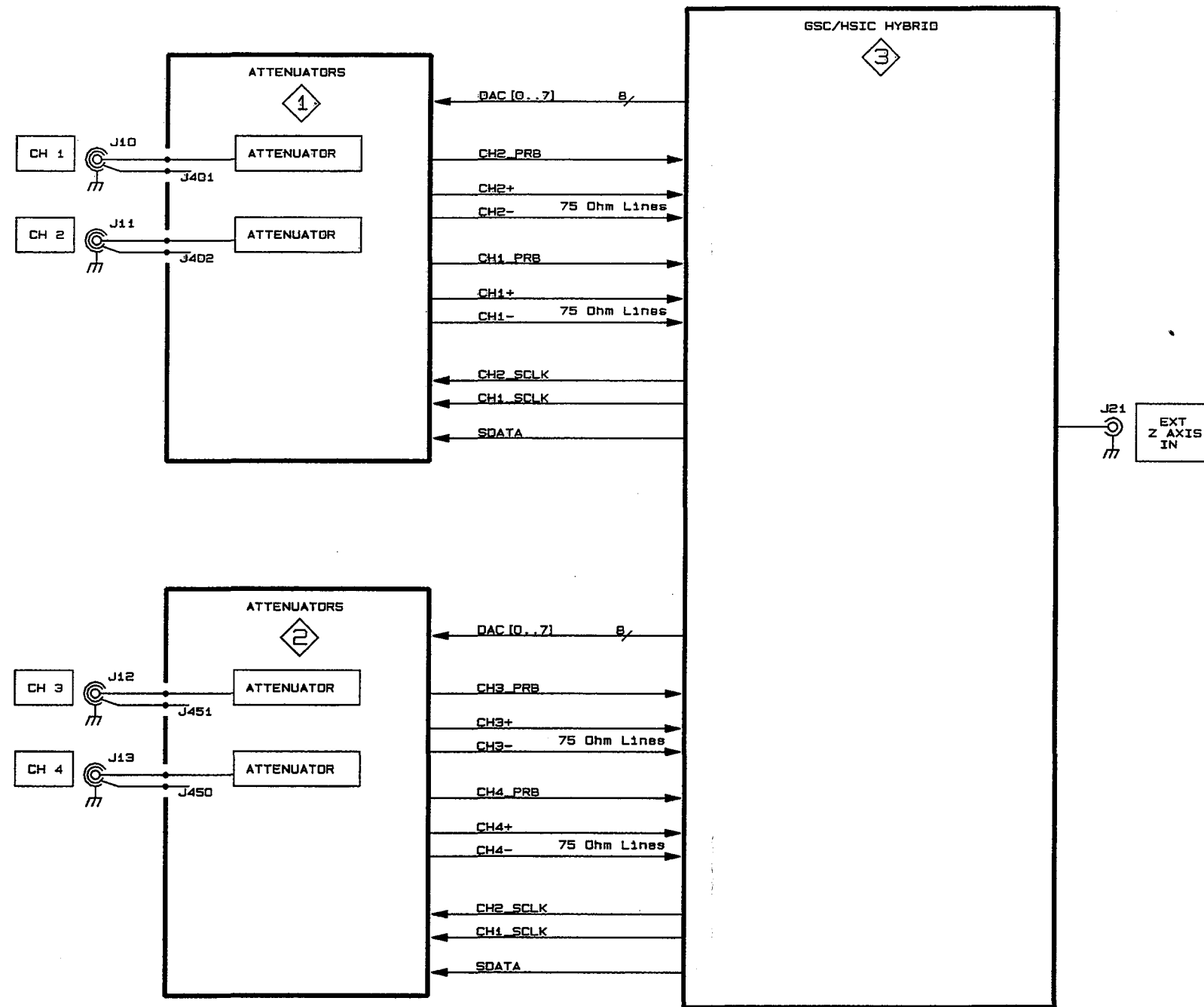

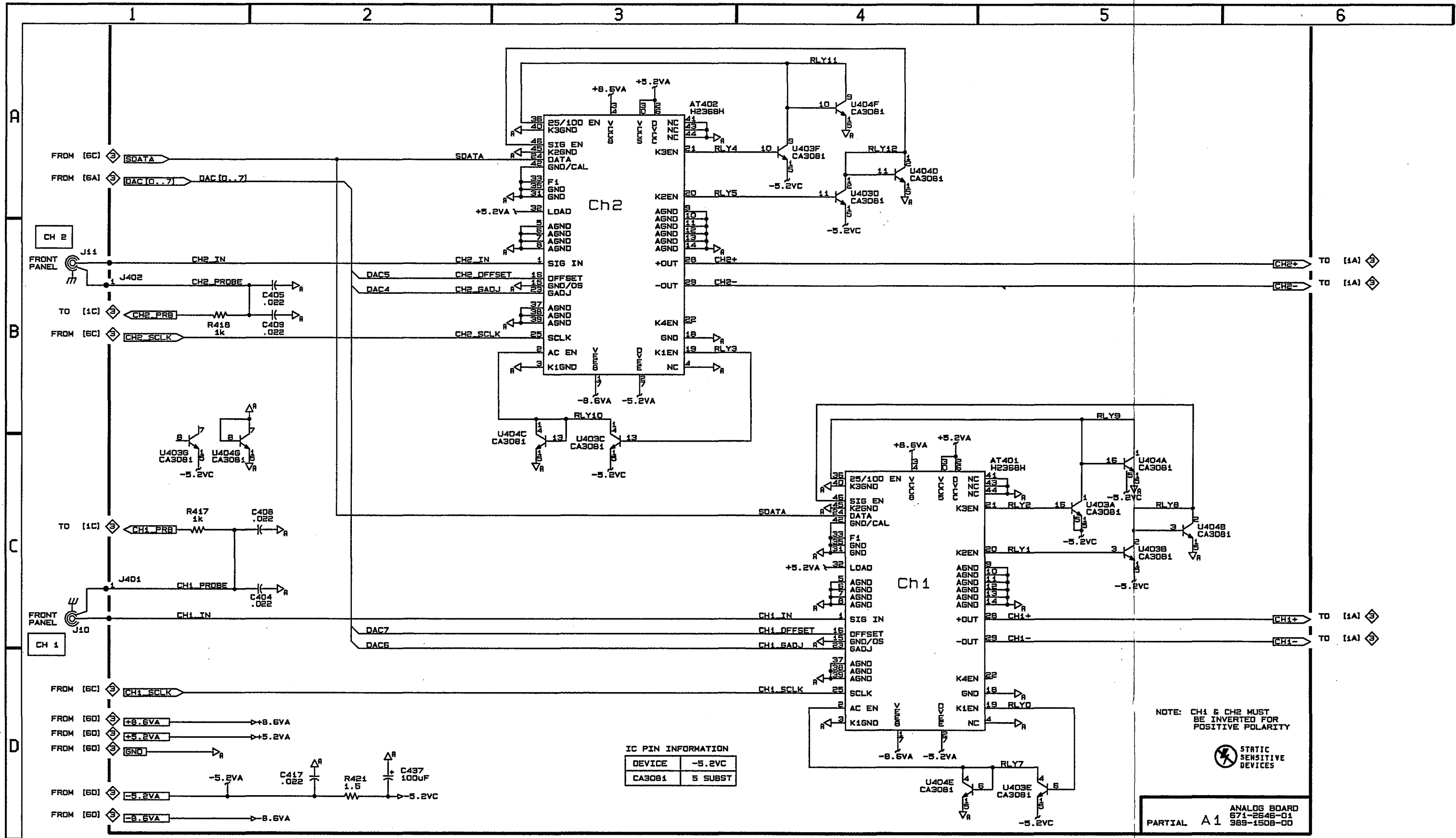

IC PIN INFORMATION

DEVICE	-5.2VC
CA3081	5 SUBST

NOTE: CH1 & CH2 MUST BE INVERTED FOR POSITIVE POLARITY



ANALOG BOARD
671-2546-01
PARTIAL A1 389-1508-00

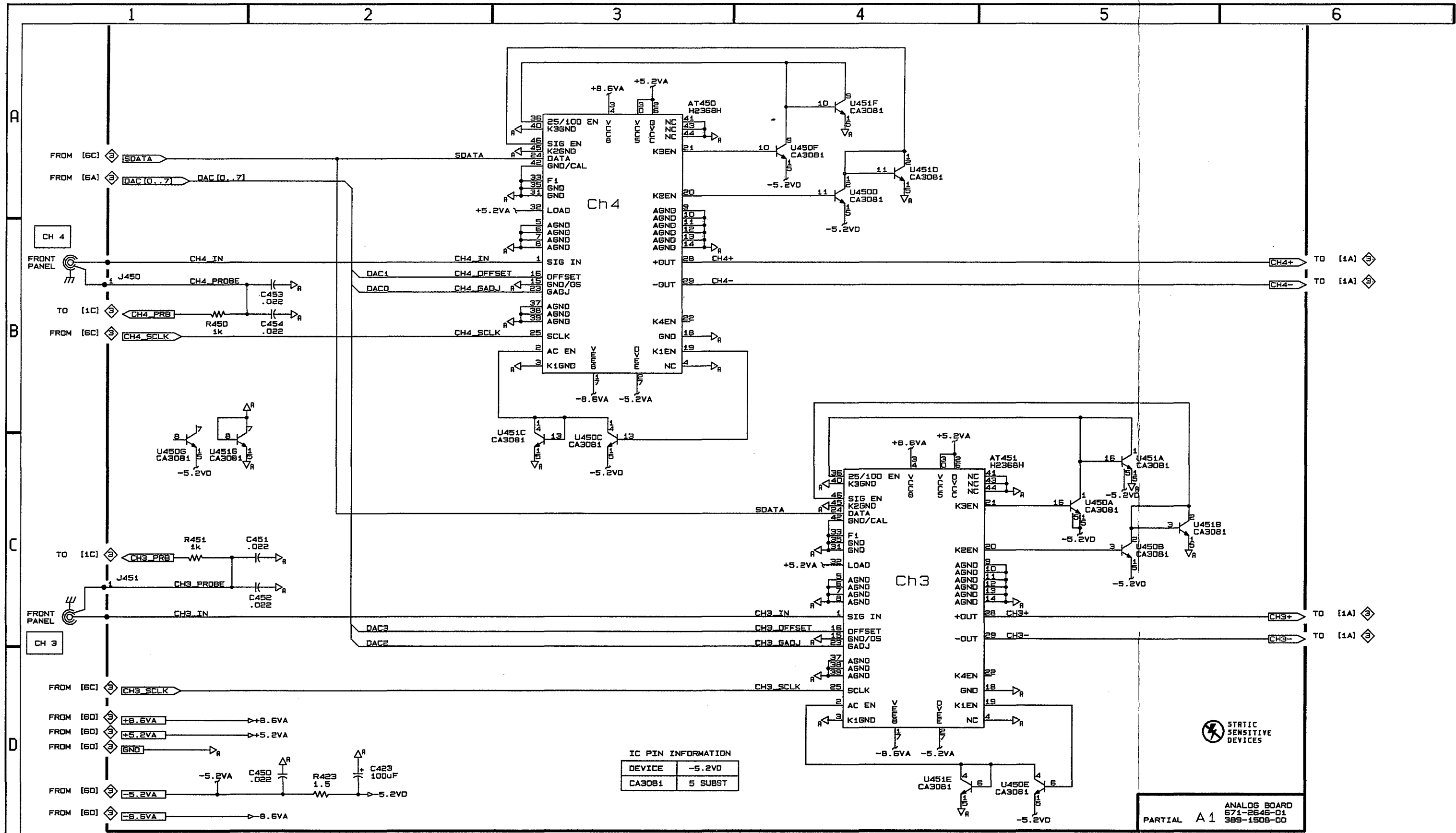

IC PIN INFORMATION

DEVICE	-5.2VD
CA3081	5 SUBST

STATIC SENSITIVE DEVICES

PARTIAL A1 ANALOG BOARD
671-2646-01
389-1508-00

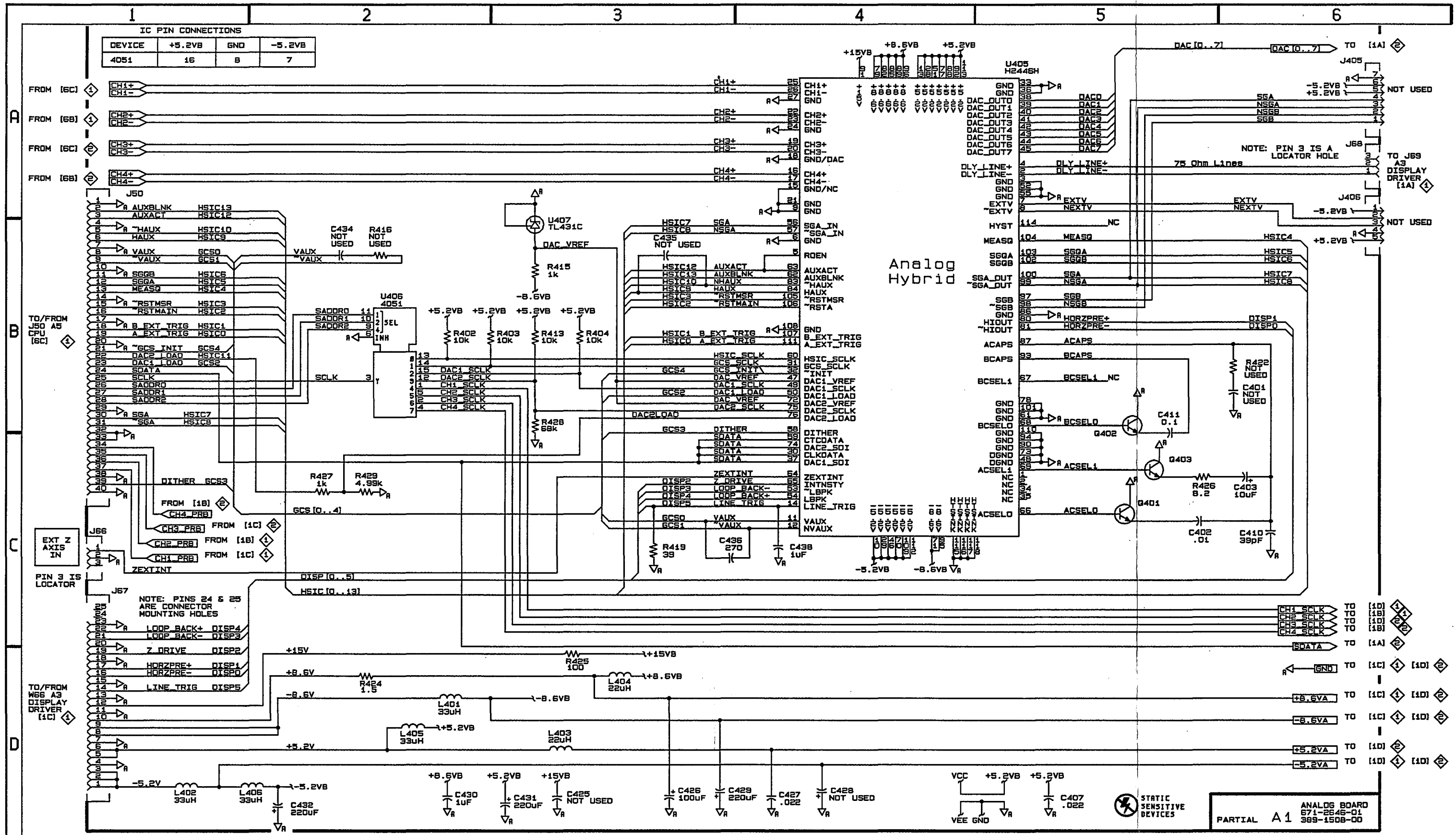

PARTIAL A1 ANALOG BOARD 671-2646-01 389-1508-00

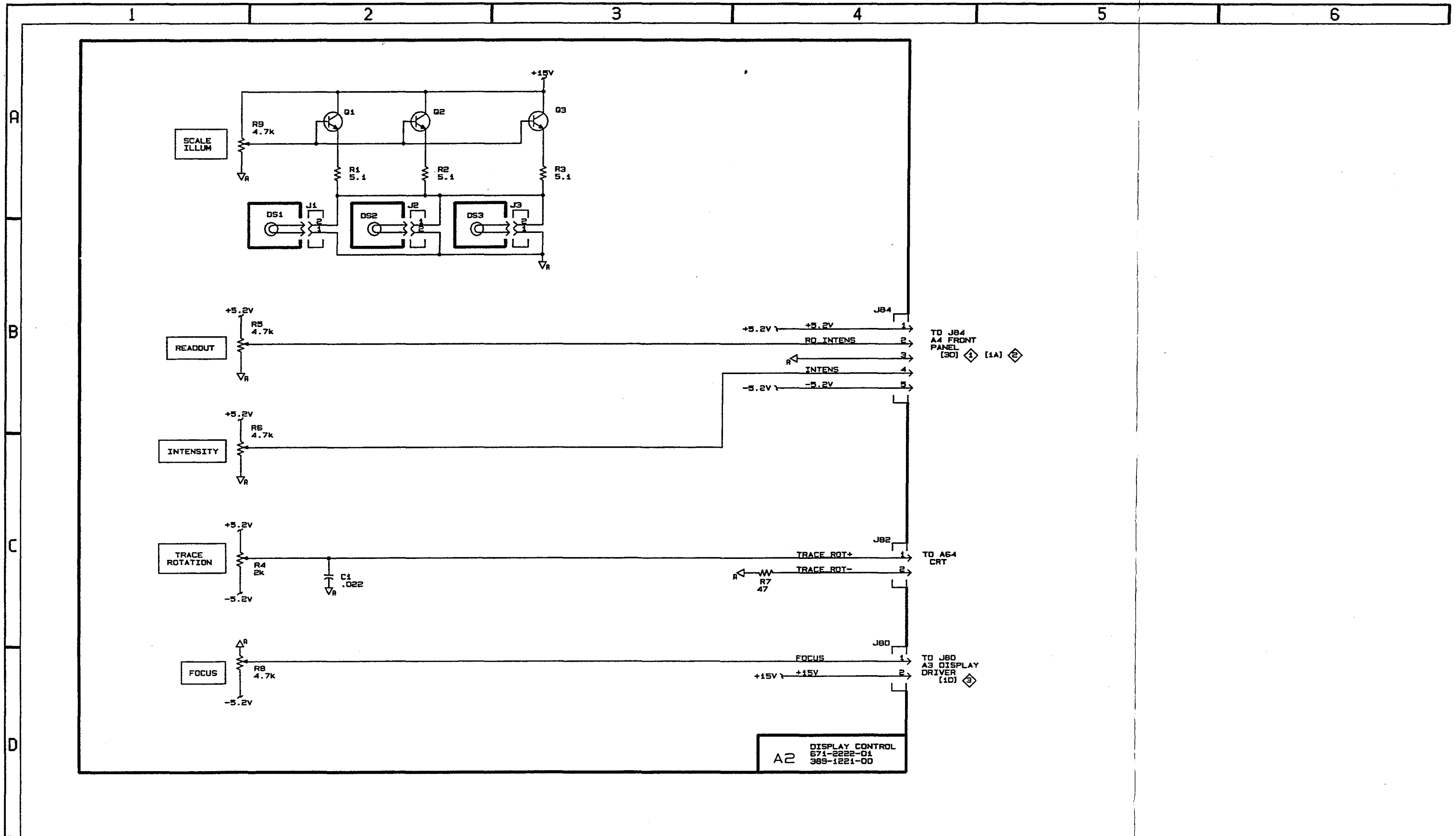

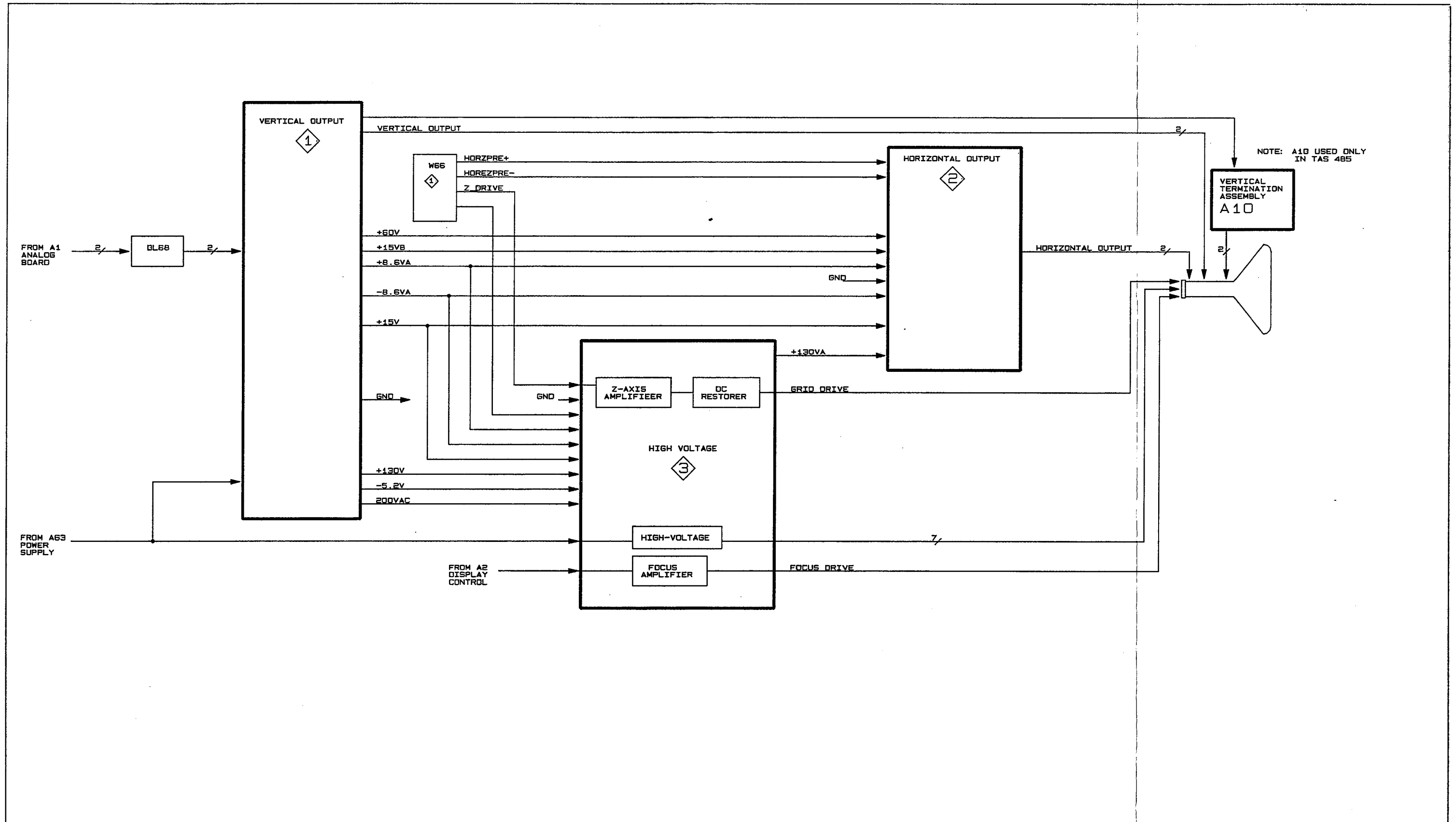

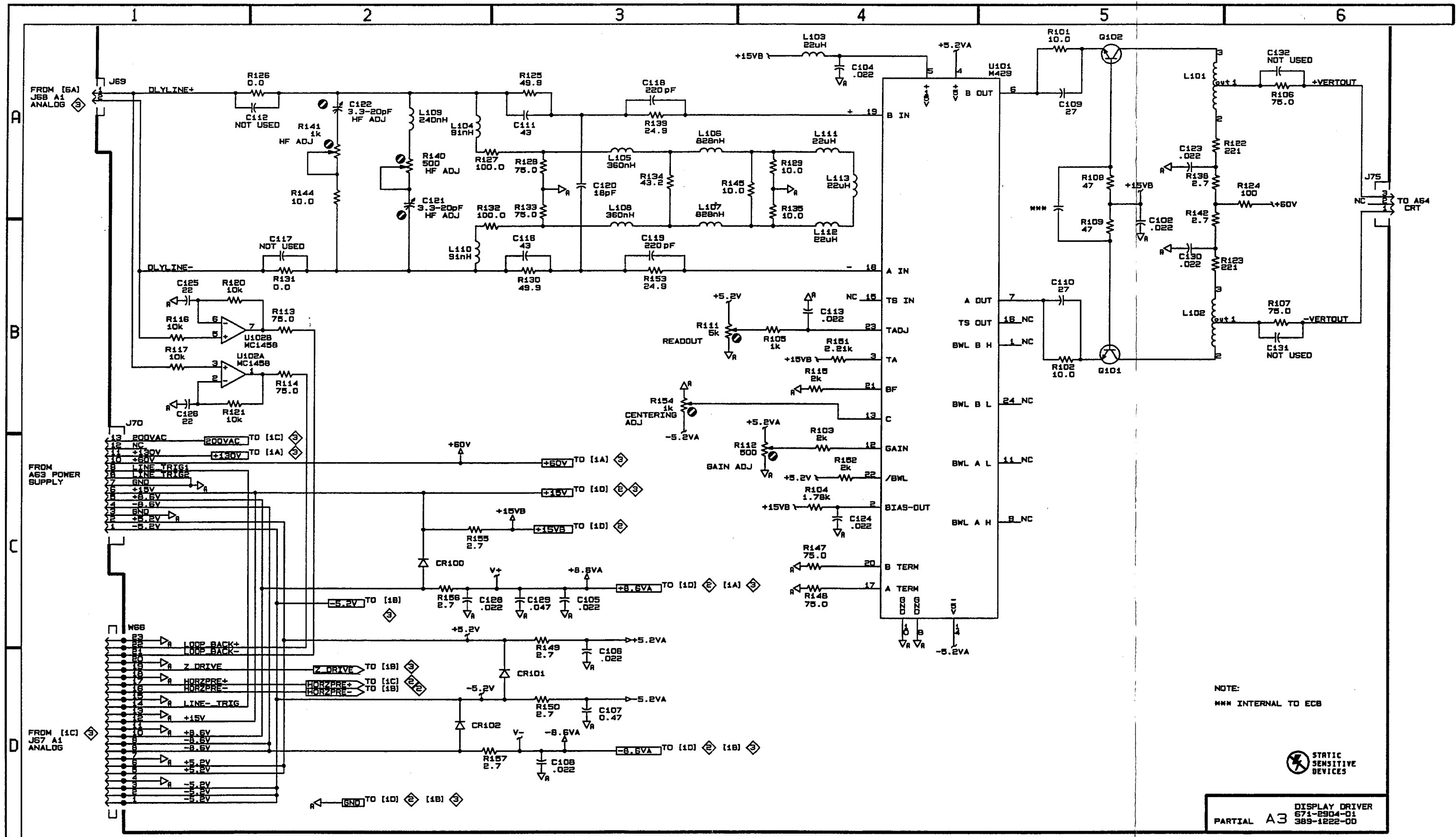

NOTE:
MXX INTERNAL TO ECB

STATIC SENSITIVE DEVICES

DISPLAY DRIVER
671-2904-01
PARTIAL A3 389-1222-00

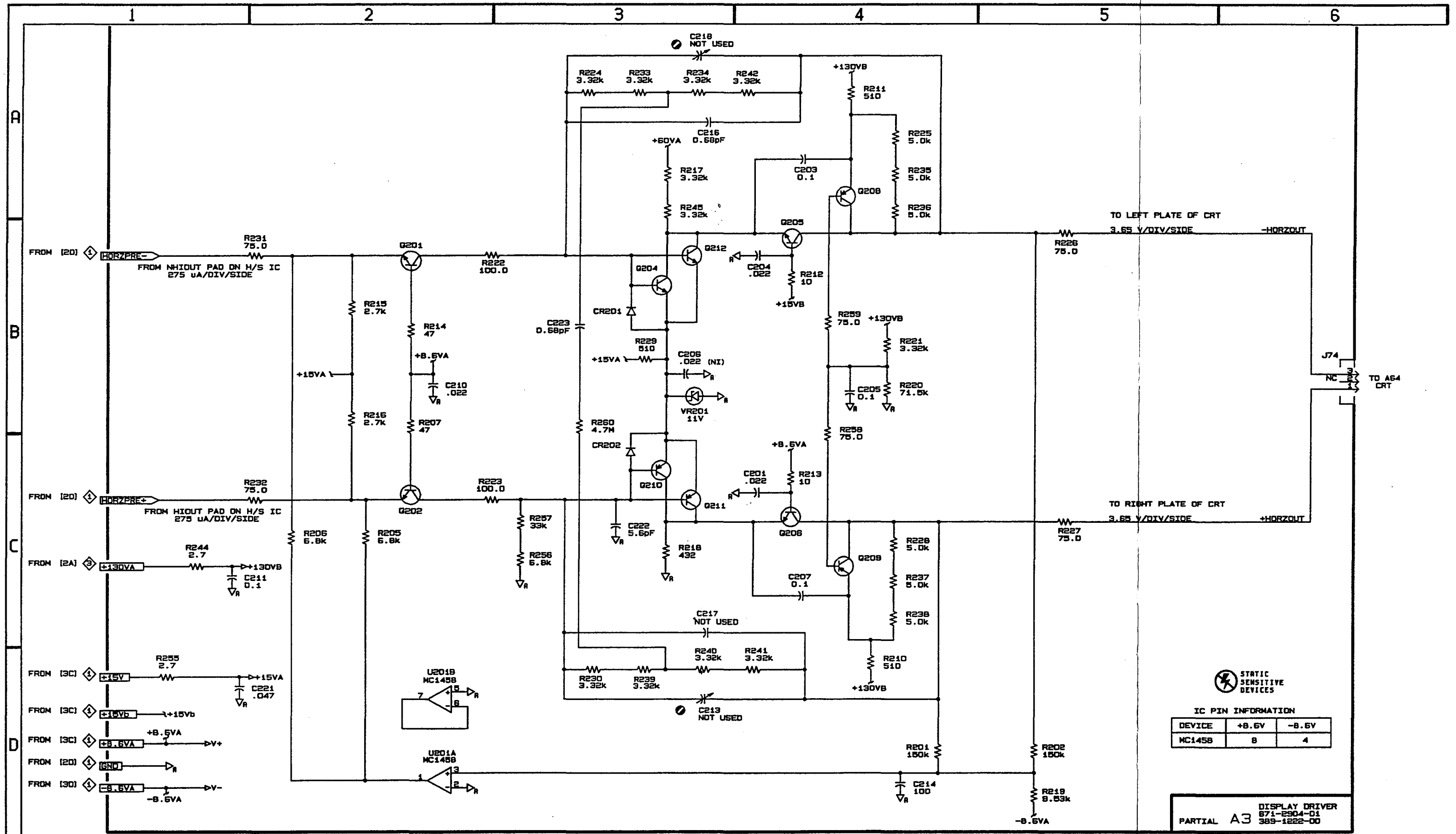

⚡ STATIC SENSITIVE DEVICES

IC PIN INFORMATION

DEVICE	+8.6V	-8.6V
MC1458	8	4

DISPLAY DRIVER
871-2904-01
PARTIAL A3 389-1222-00

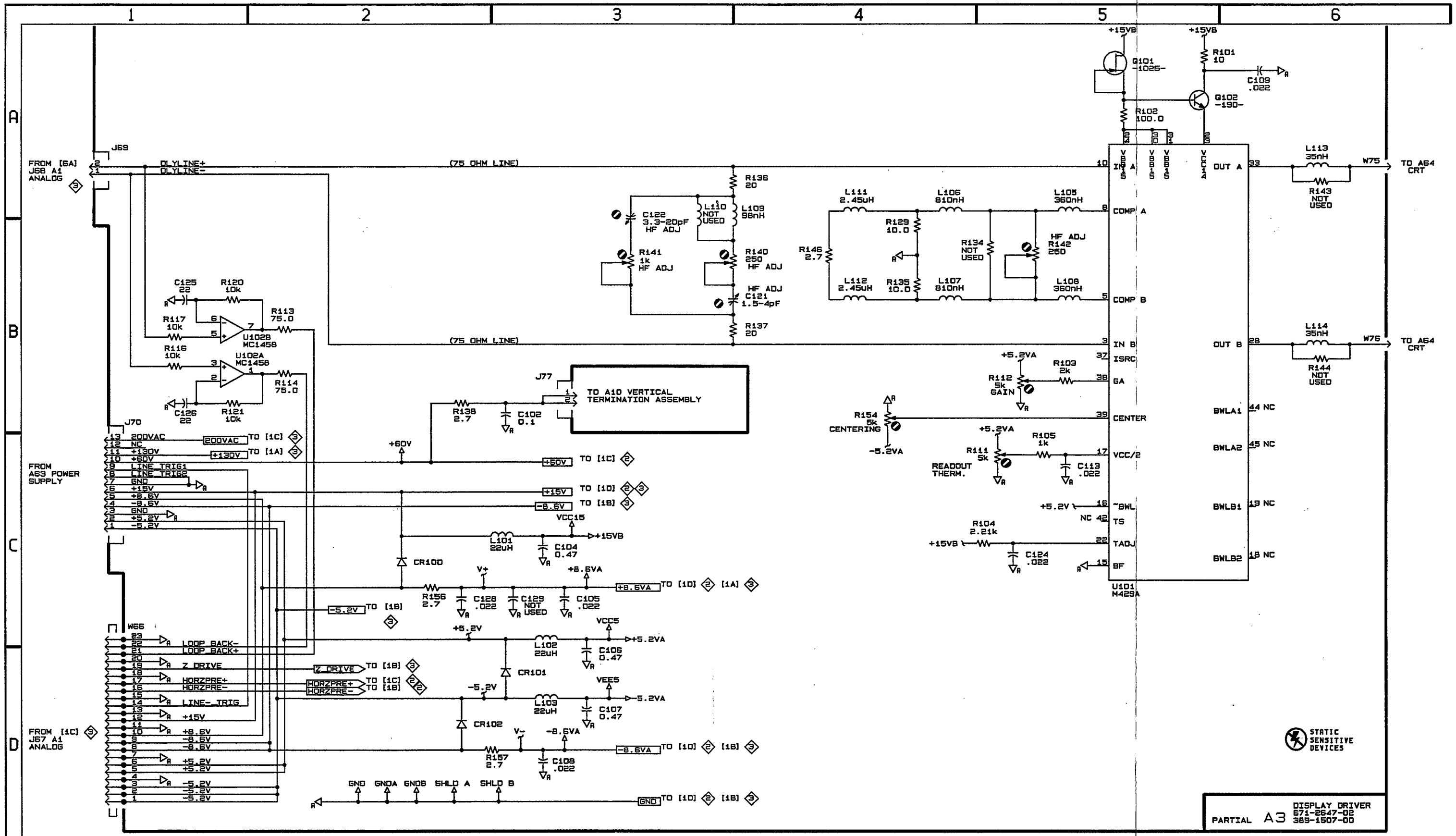

DISPLAY DRIVER
 671-2647-02
 389-1507-00

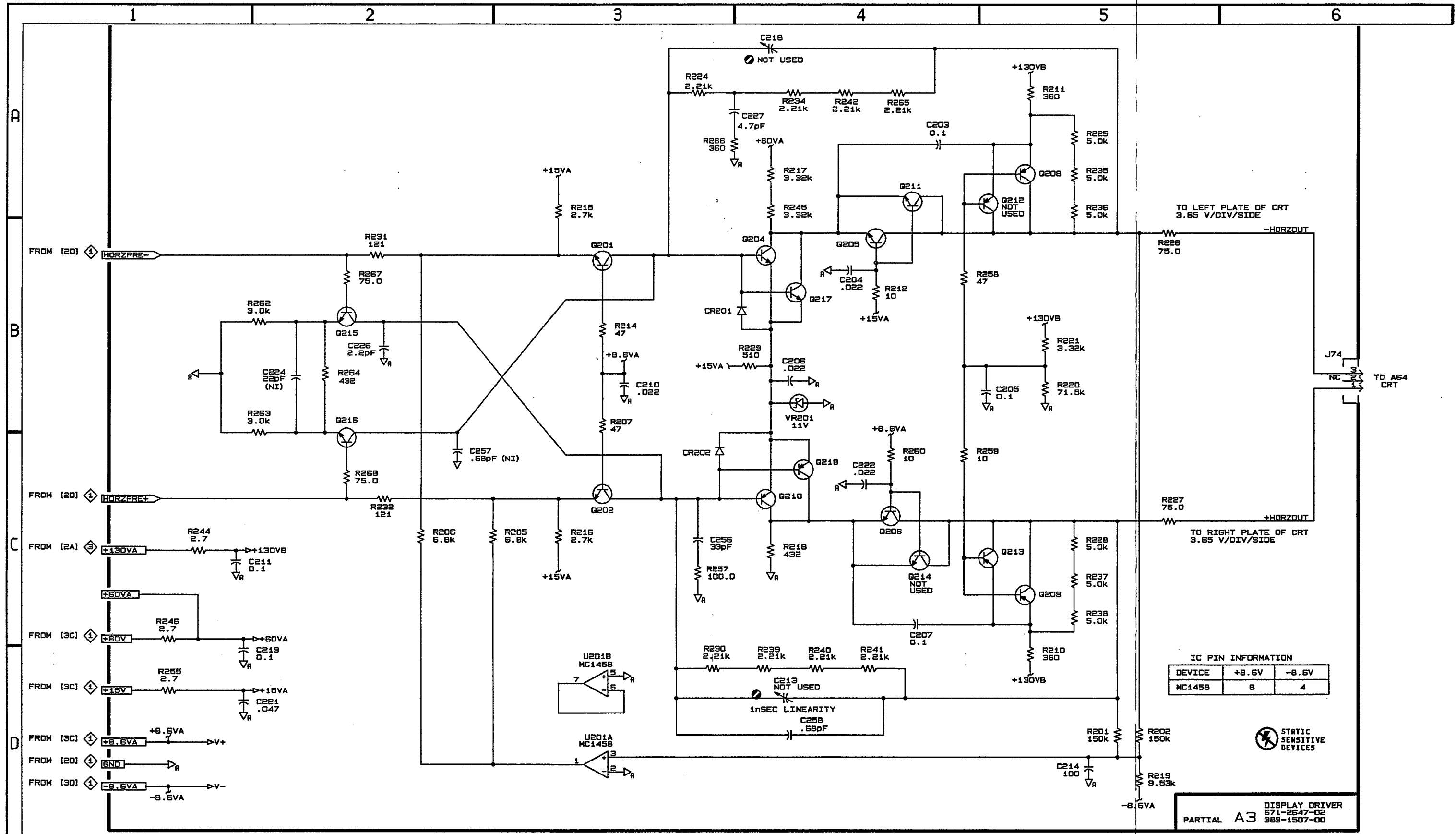

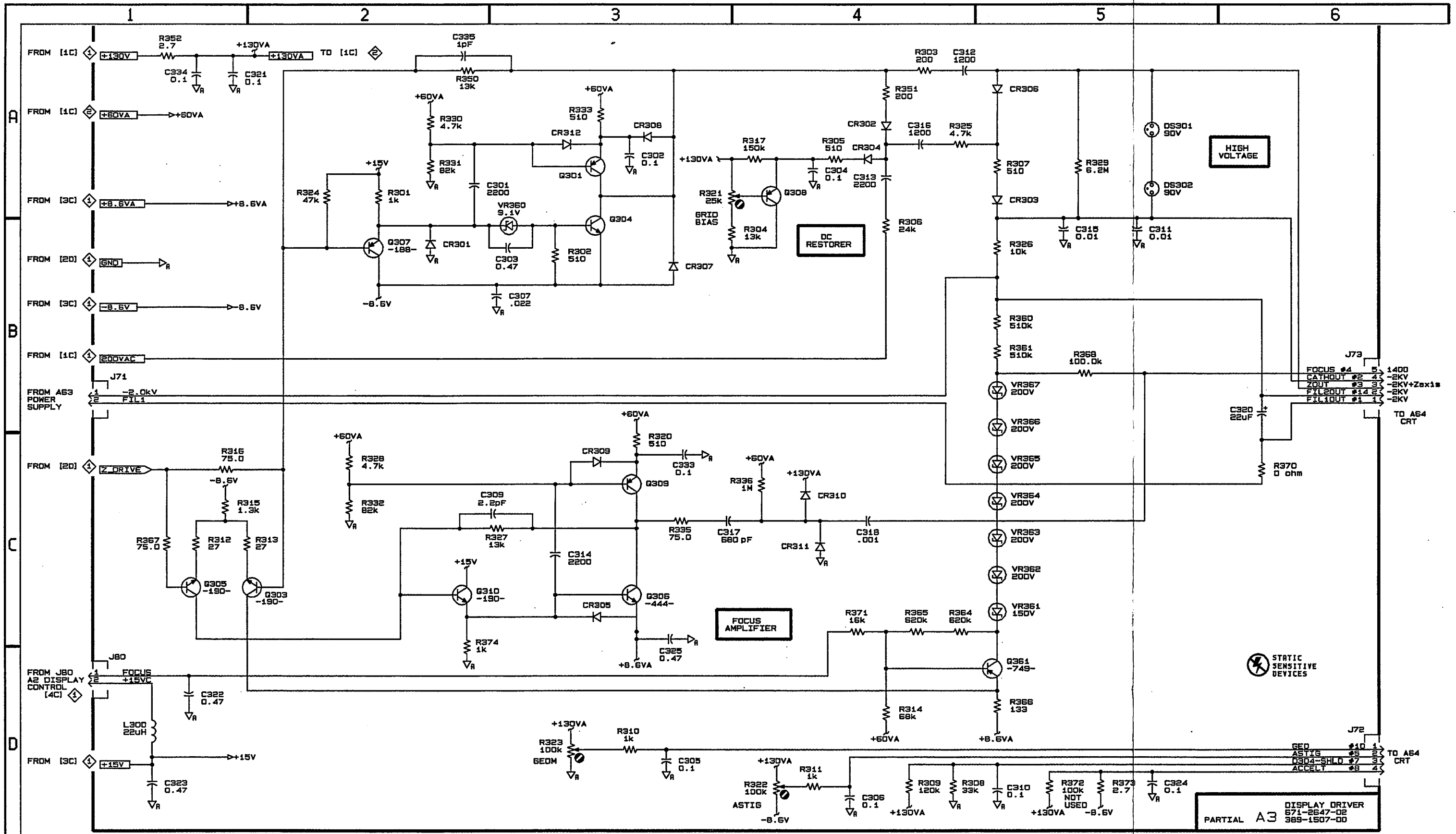

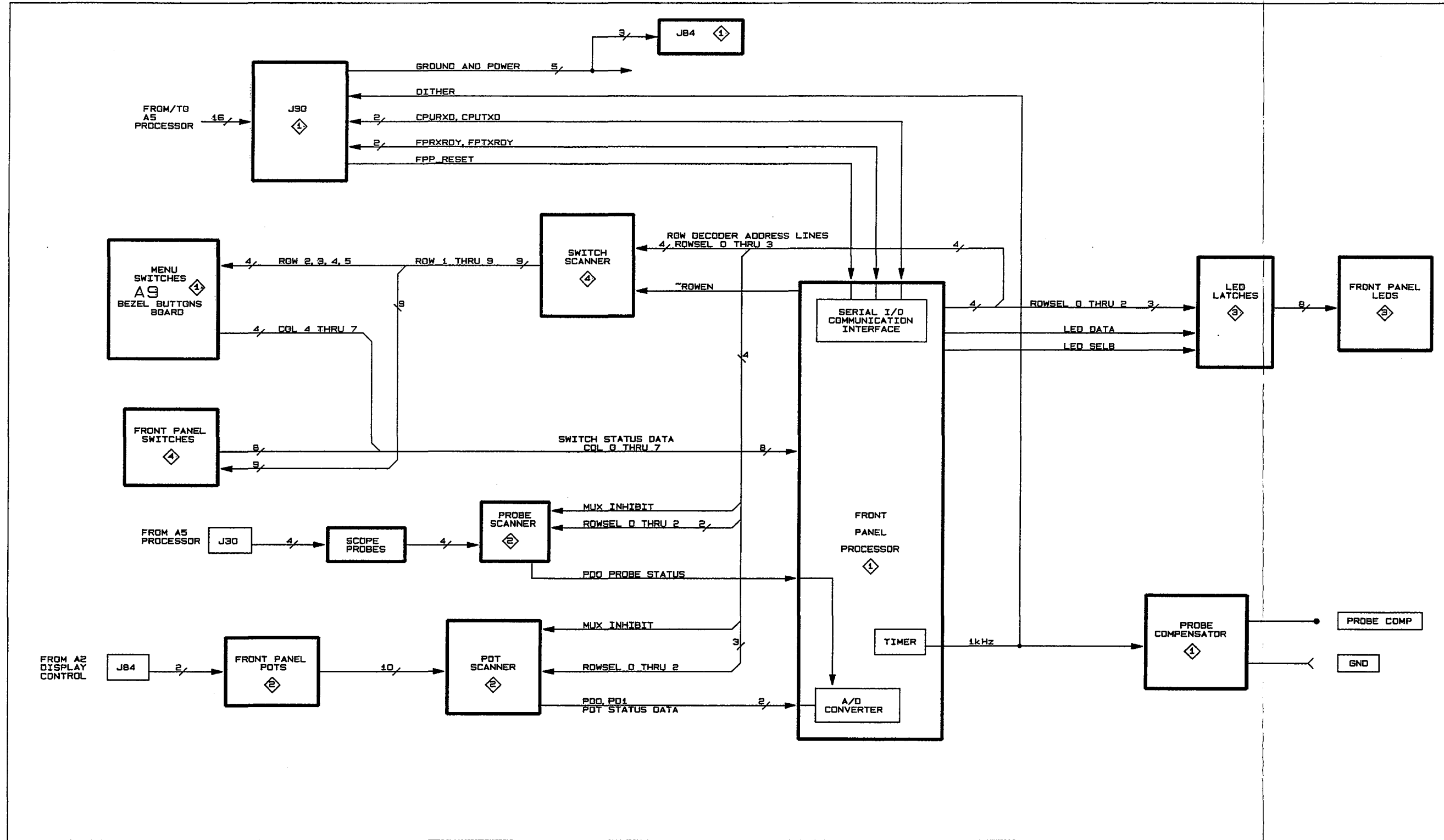

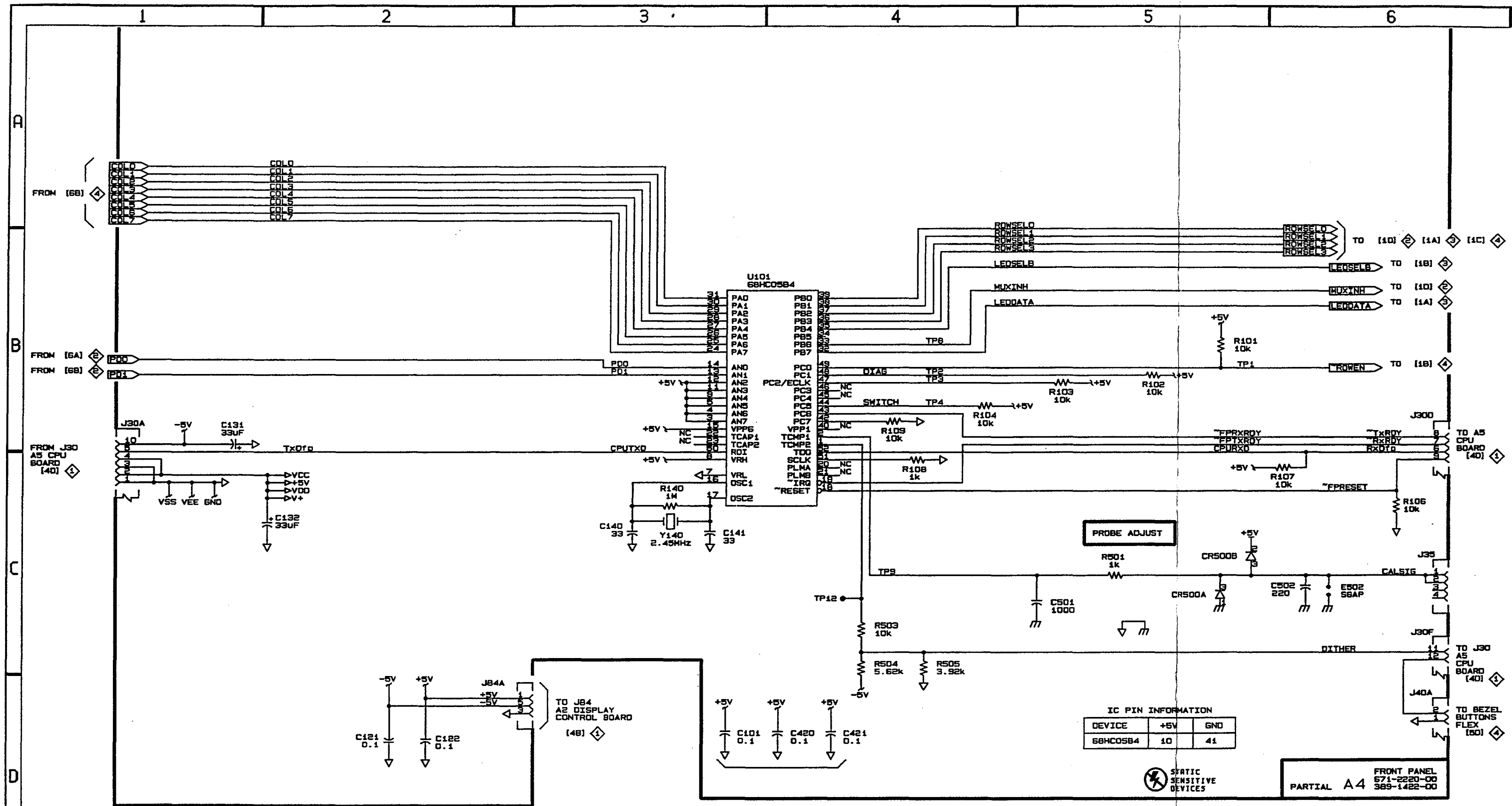

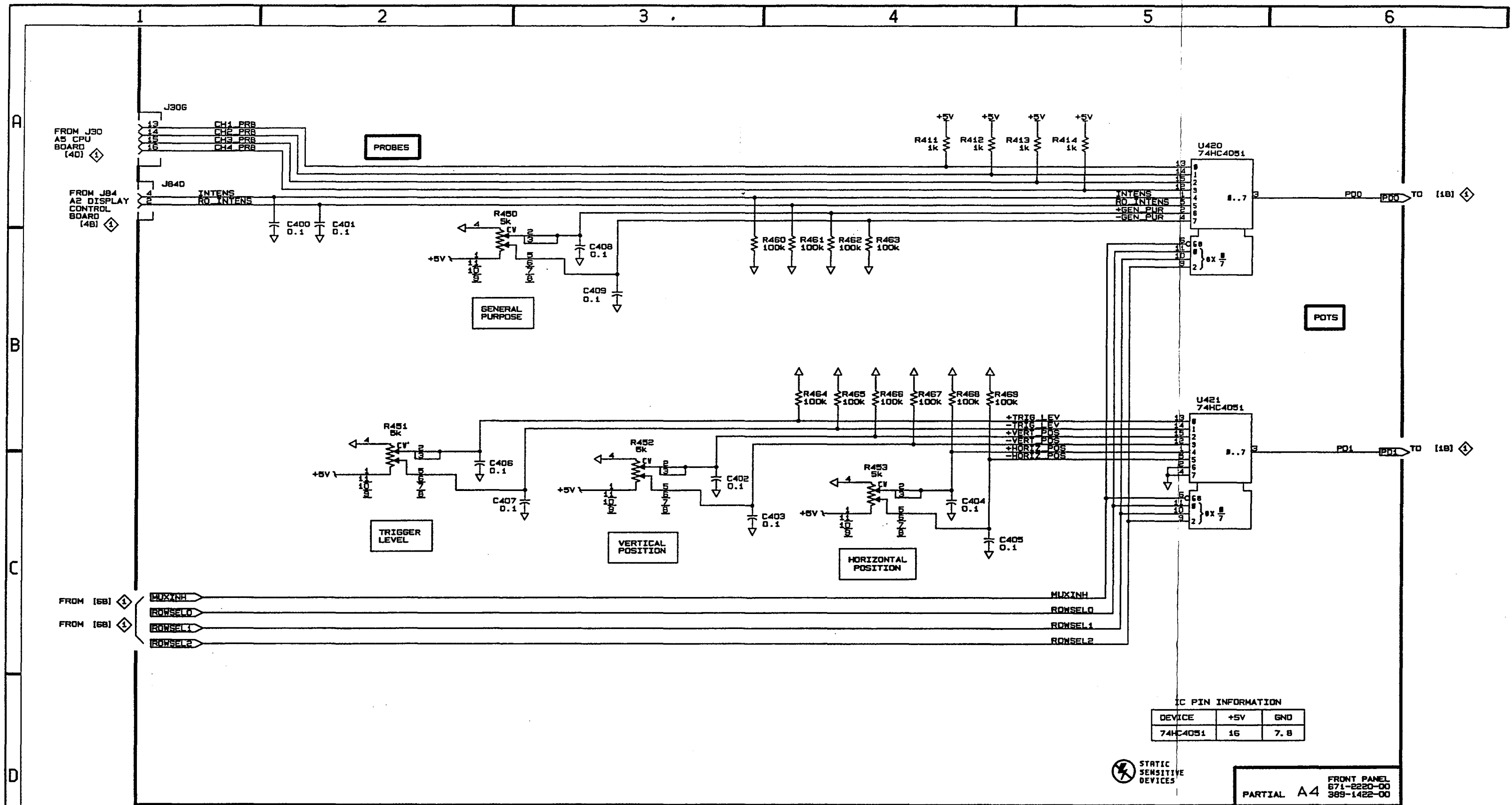

IC PIN INFORMATION

DEVICE	+5V	GND
74HC4051	16	7, 8

⚡ STATIC SENSITIVE DEVICES

FRONT PANEL
671-2220-00
PARTIAL A4 385-1422-00

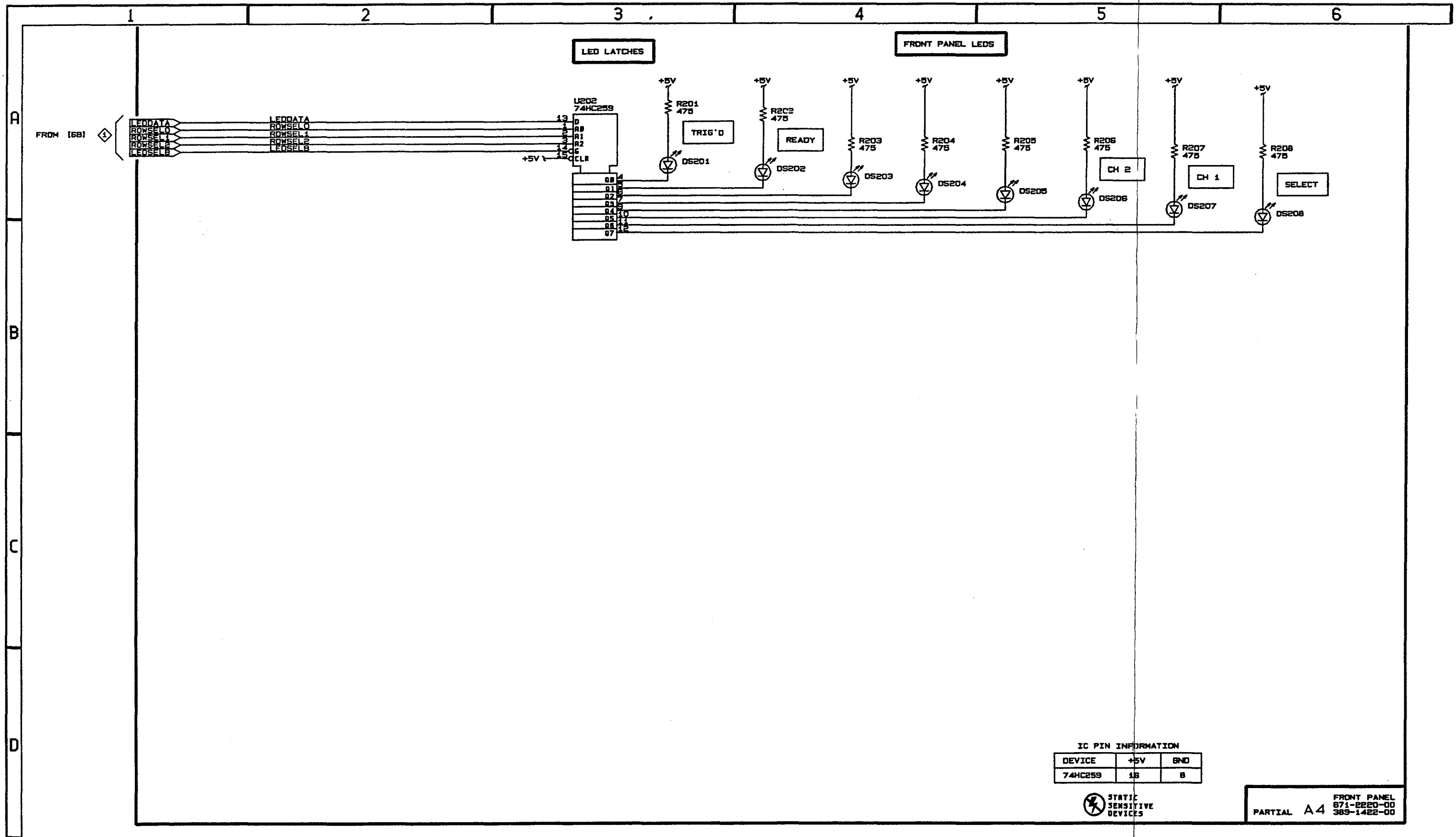

IC PIN INFORMATION

DEVICE	+5V	8ND
74HC259	1B	8

⚡ STATIC SENSITIVE DEVICES

PARTIAL A4 FRONT PANEL
671-2220-00
389-1422-00

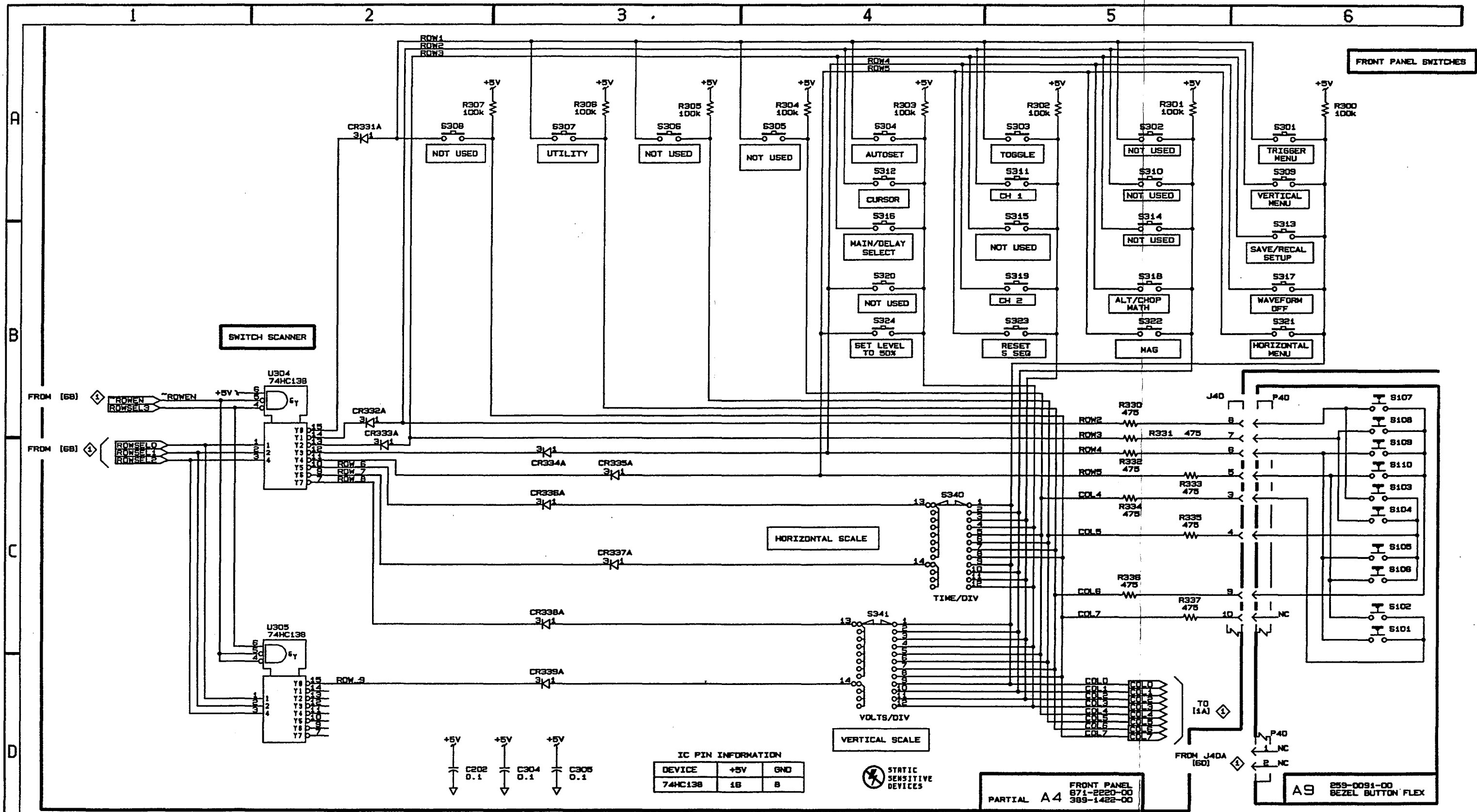

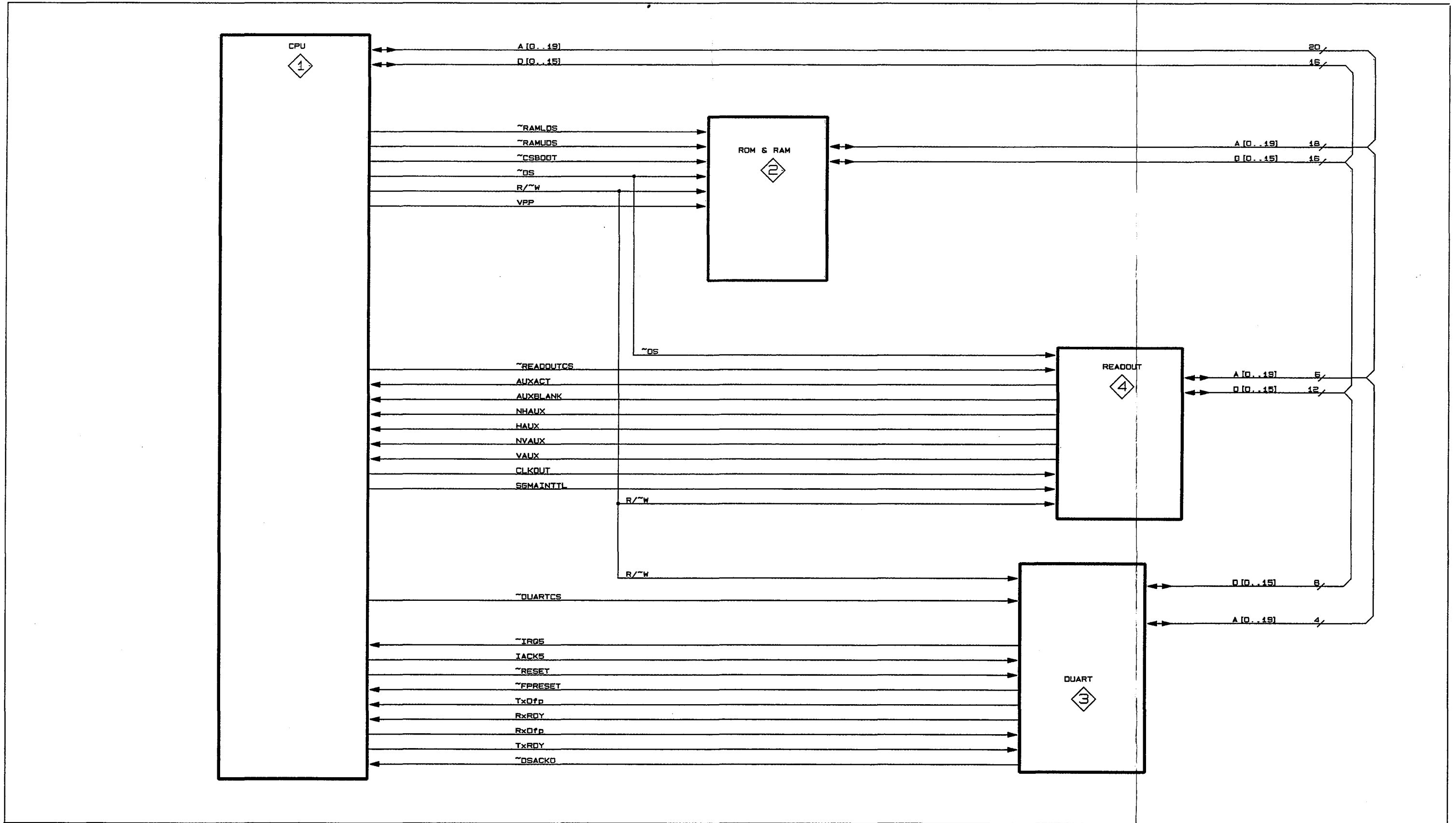

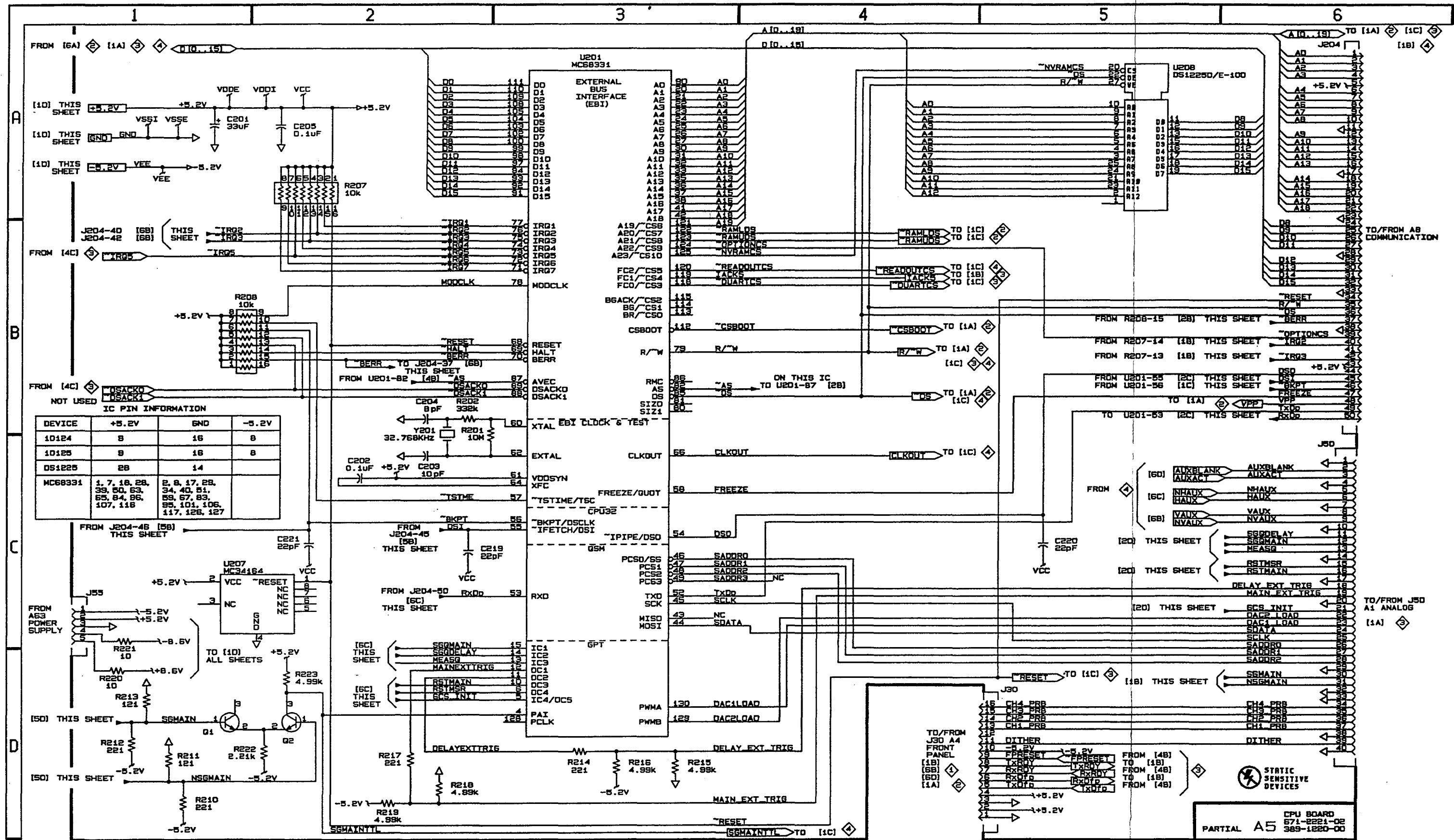

IC PIN INFORMATION

DEVICE	+5.2V	GND	-5.2V
10124	8	16	8
10125	8	16	8
DS1225	28	14	
MC68331	1, 7, 18, 28, 39, 50, 63, 65, 84, 86, 107, 118	2, 8, 17, 28, 34, 40, 51, 59, 67, 83, 95, 101, 106, 117, 128, 127	

TAS 475/485

TAS 475 8010570 & BELOW
TAS 485 8010320 & BELOW

CPU BOARD
571-2221-02
389-1220-00

CPU A5

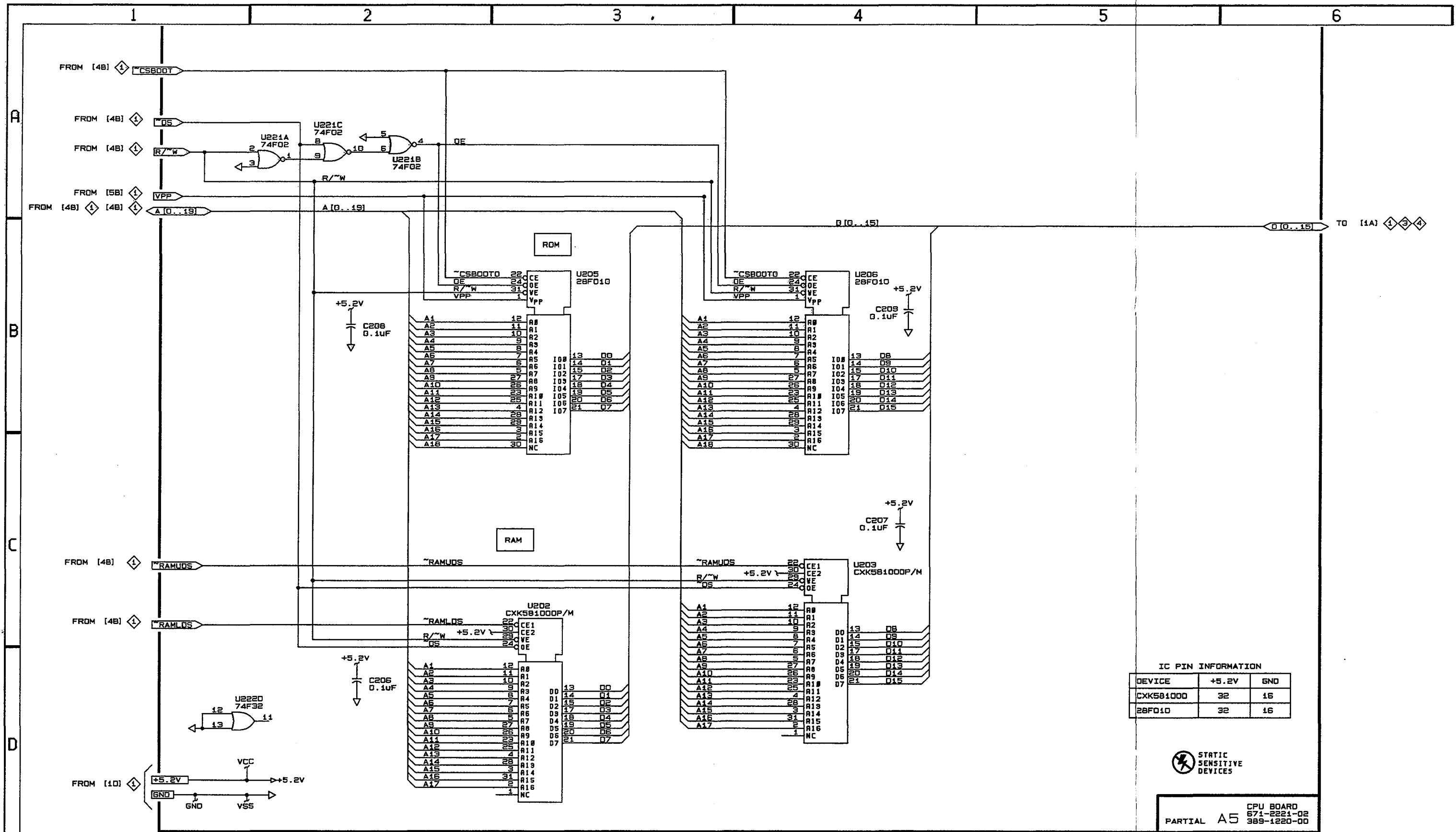

IC PIN INFORMATION

DEVICE	+5.2V	GND
CXK581000	32	16
28F010	32	16

⚡ STATIC SENSITIVE DEVICES

CPU BOARD
671-2221-02
PARTIAL A5 389-1220-00

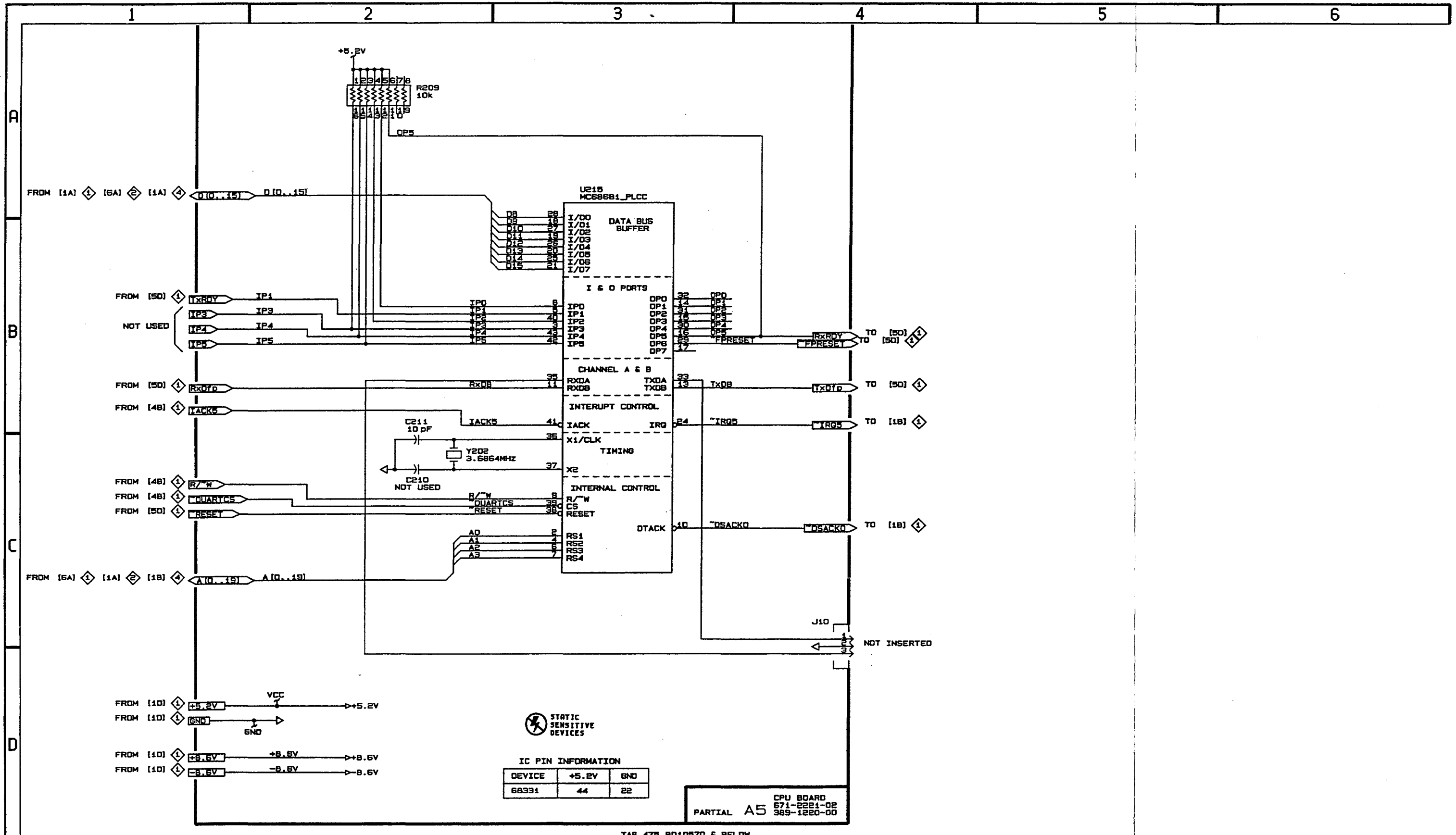

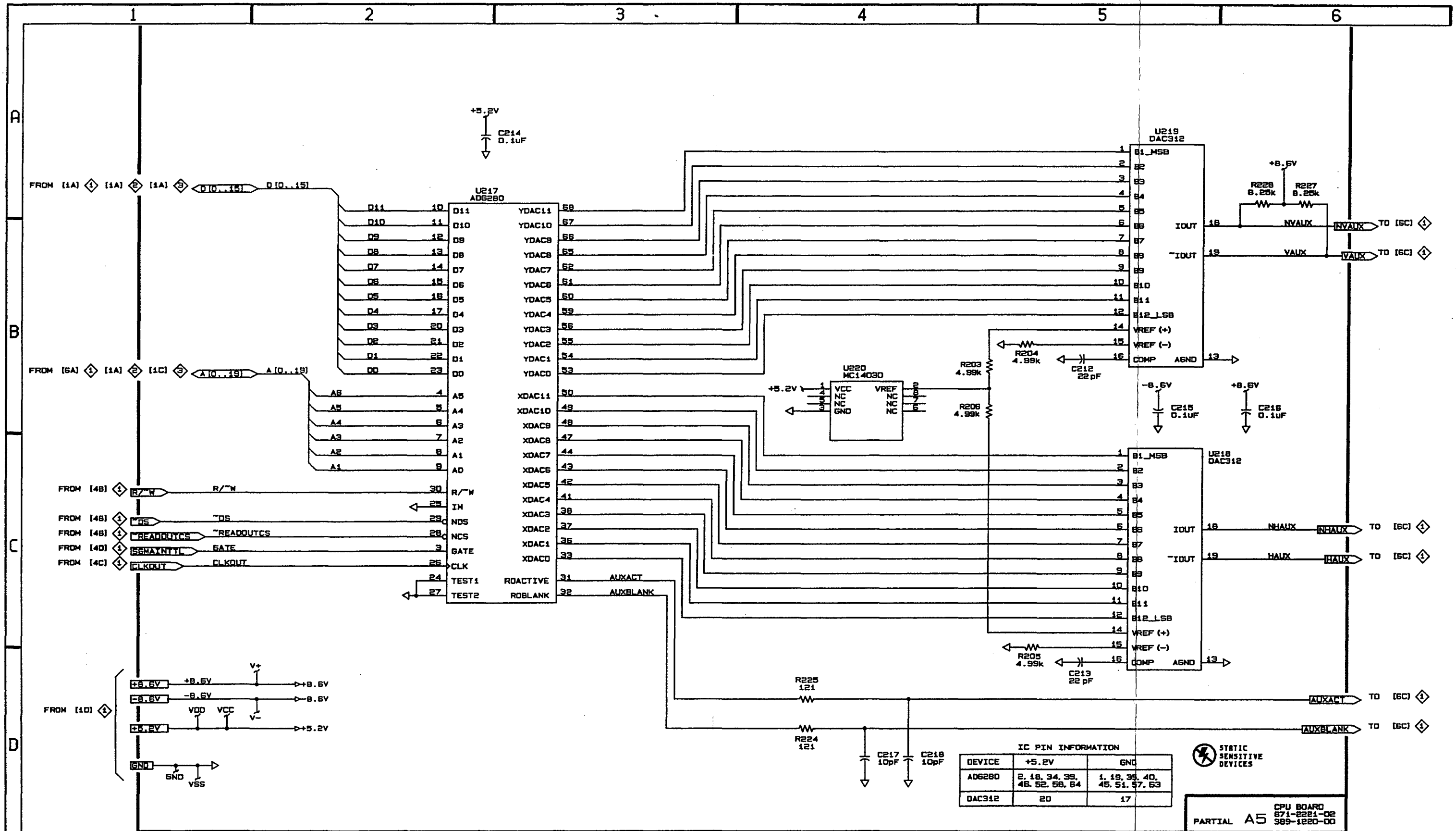

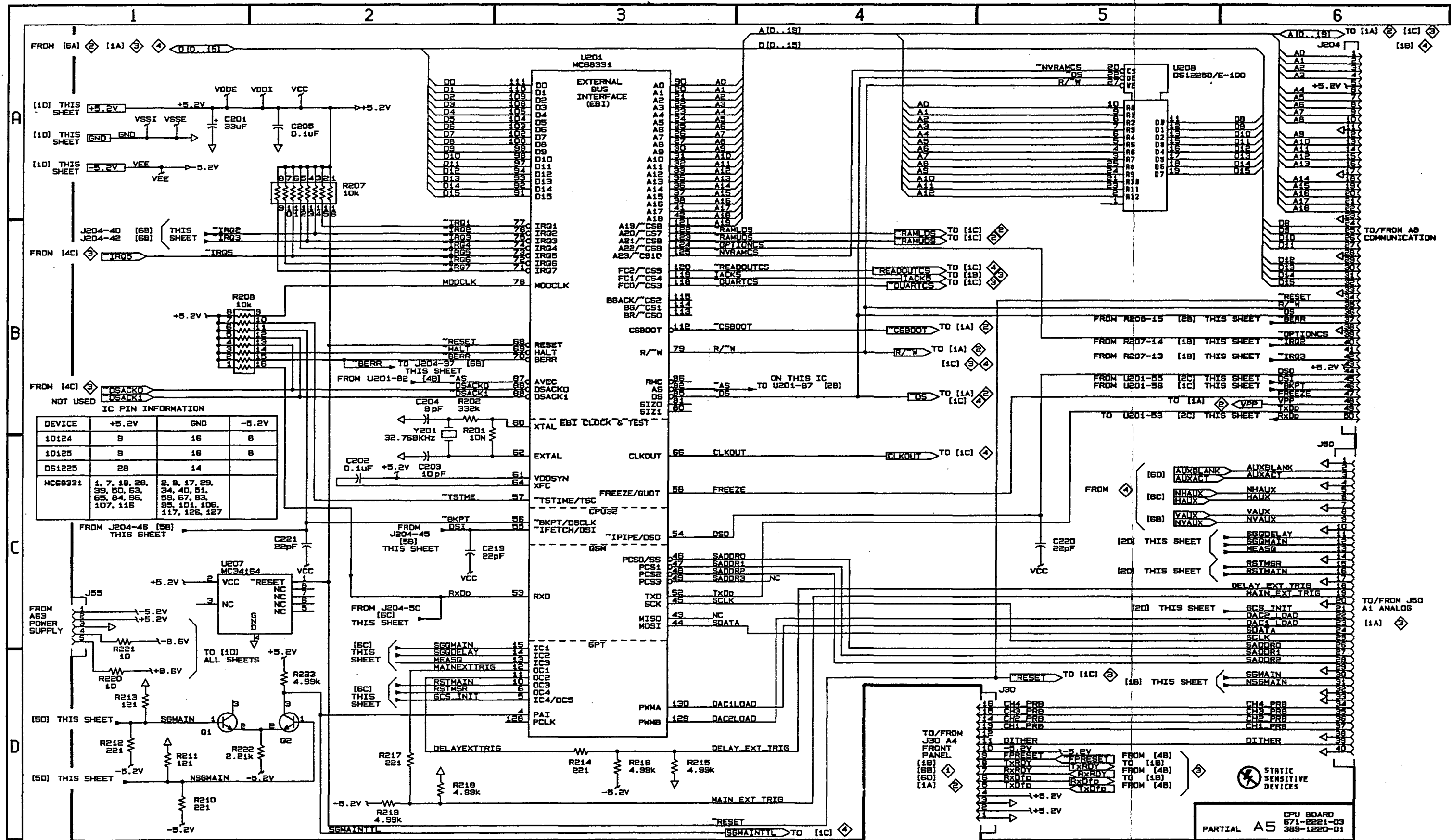

TAS 475/485

TAS 475 8010571 & ABOVE
TAS 485 8010321 & ABOVE

CPU BOARD
671-2221-03
389-1220-01
PARTIAL A5

CPU A5

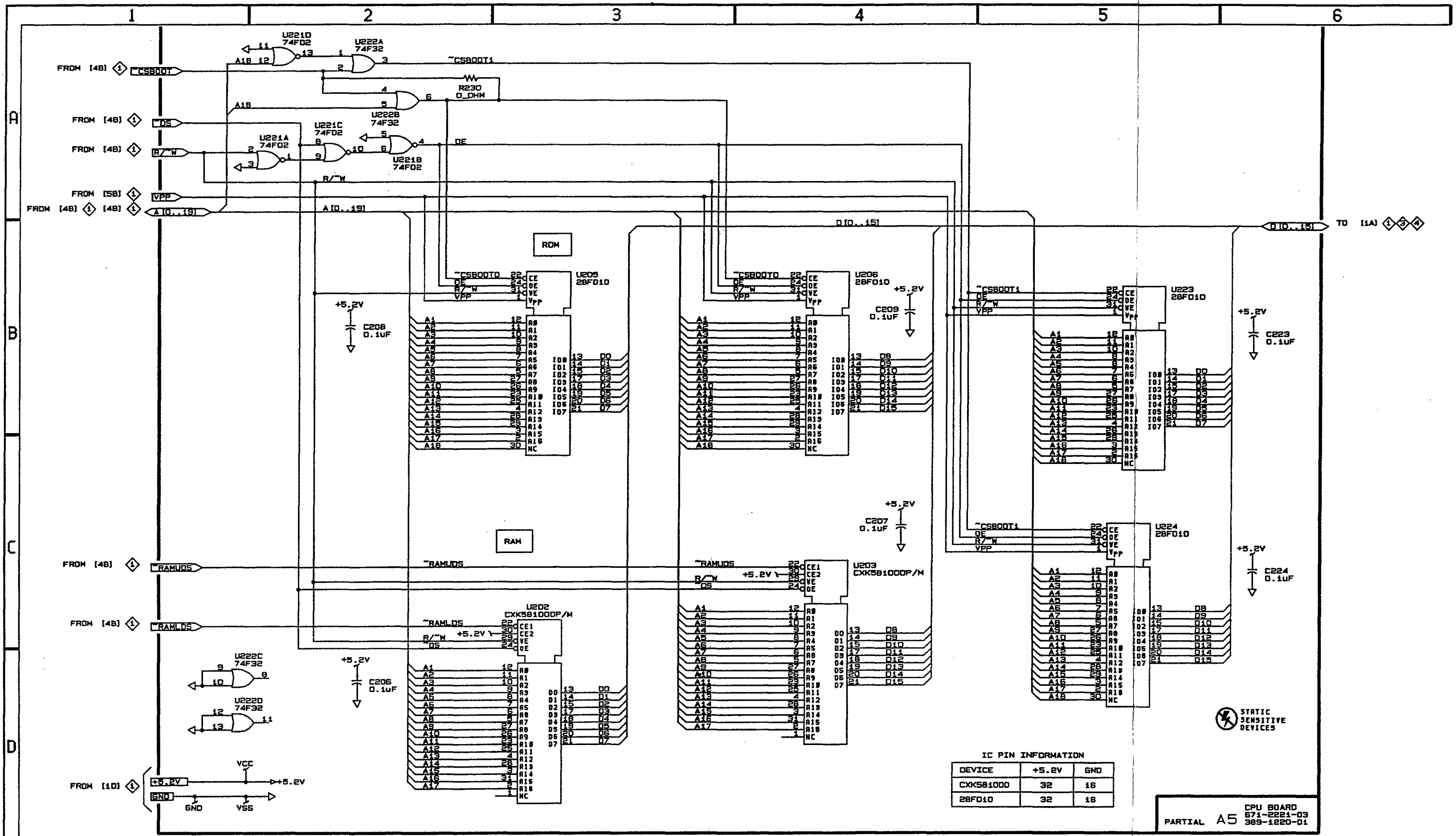

IC PIN INFORMATION

DEVICE	+5.2V	GND
CXK581000	32	16
28F010	32	16

STATIC SENSITIVE DEVICES

CPU BOARD
571-2221-03
389-1220-01
PARTIAL A5

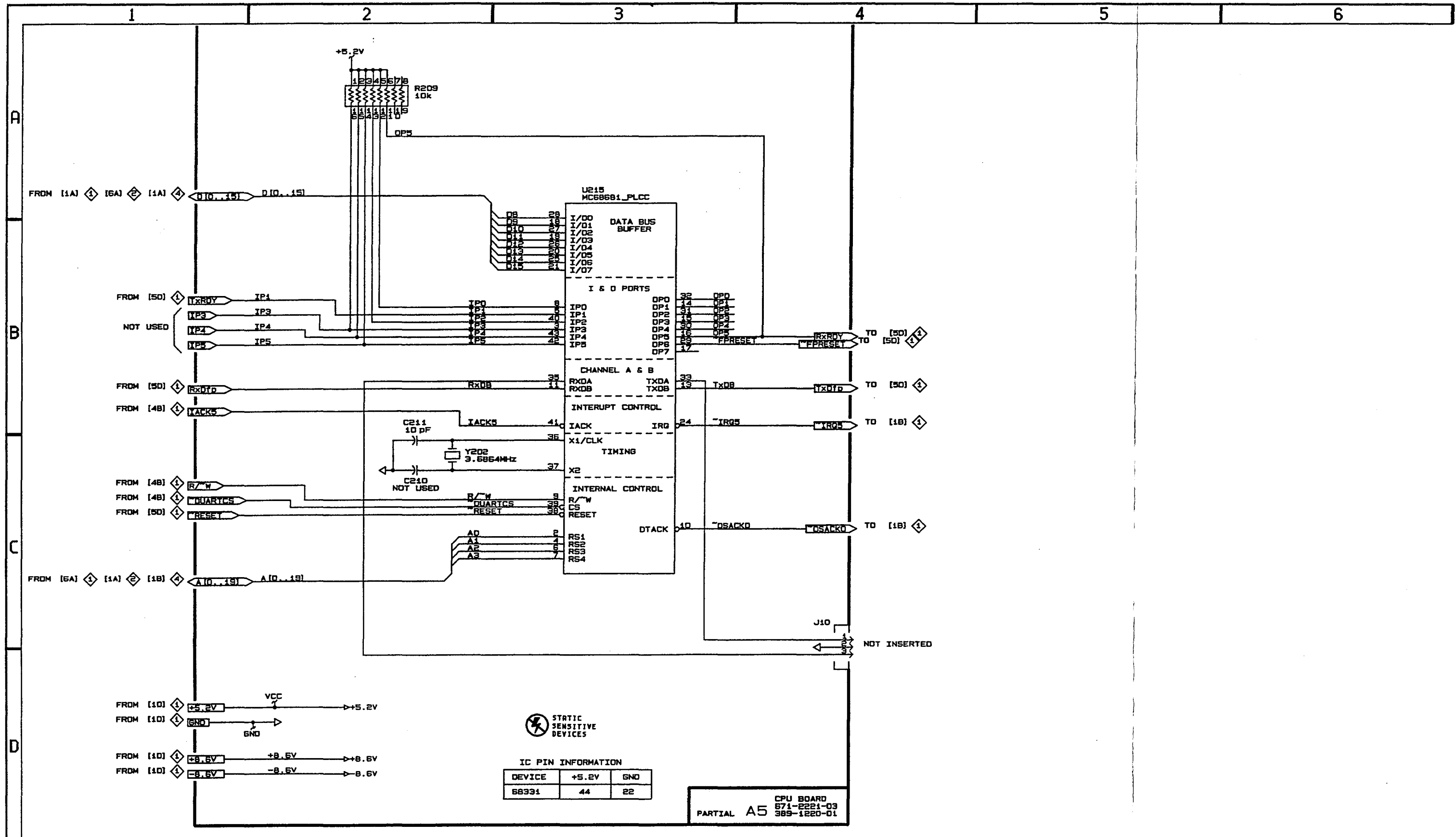

⚡ STATIC SENSITIVE DEVICES

IC PIN INFORMATION

DEVICE	+5.2V	GND
68931	44	22

PARTIAL A5 CPU BOARD
671-2221-03
385-1220-01

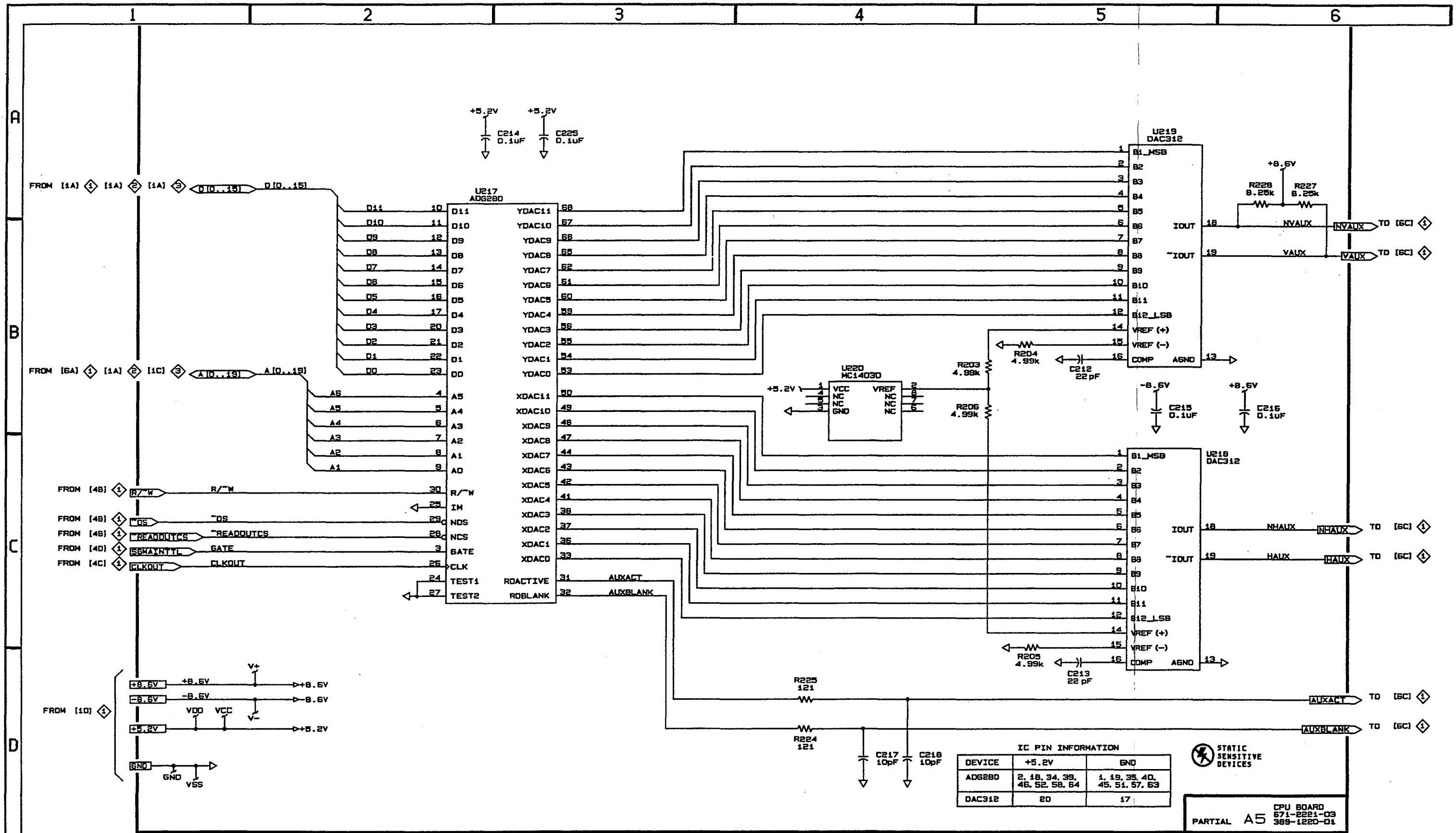

Replaceable Mechanical Parts

This section contains a list of the components that are replaceable for the **products**. As described below, use this list to identify and order replacement parts. There is a separate Replaceable Parts List for each instrument.

Parts Ordering Information

Replacement parts are available from or through your local Tektronix, Inc., service center or representative.

Changes to Tektronix instruments are sometimes made to accommodate improved components as they become available and to give you the benefit of the latest circuit improvements. Therefore, when ordering parts, it is important to include the following information in your order:

- Part number
- Instrument type or model number
- Instrument serial number
- Instrument modification number, if applicable

If a part you order has been replaced with a different or improved part, your local Tektronix service center or representative will contact you concerning any change in the part number.

Using the Replaceable Parts List

The tabular information in the Replaceable Parts List is arranged for quick retrieval. Understanding the structure and features of the list will help you find the all the information you need for ordering replacement parts.

Item Names

In the Replaceable Parts List, an Item Name is separated from the description by a colon (:). Because of space limitations, an Item Name may sometimes appear as incomplete. For further Item Name identification, U.S. Federal Cataloging Handbook H6-1 can be used where possible.

Indentation System

This parts list is indented to show the relationship between items. The following example is of the indentation system used in the Description column:

<i>1</i>	<i>2</i>	<i>3</i>	<i>4</i>	<i>5</i>	<i>Name & Description</i>
					<i>Assembly and/or Component</i>
					<i>Attaching parts for Assembly and/or Component</i>
					<i>(END ATTACHING PARTS)</i>
					<i>Detail Part of Assembly and/or Component</i>
					<i>Attaching parts for Detail Part</i>
					<i>(END ATTACHING PARTS)</i>
					<i>Parts of Detail Part</i>
					<i>Attaching parts for Parts of Detail Part</i>
					<i>(END ATTACHING PARTS)</i>

Attaching parts always appear at the same indentation as the item it mounts, while the detail parts are indented to the right. Indented items are part of, and included with, the next higher indentation. Attaching parts must be purchased separately, unless otherwise specified.

Abbreviations

Abbreviations conform to American National Standards Institute (ANSI) standard Y1.1

CROSS INDEX – MFR. CODE NUMBER TO MANUFACTURER

Mfr. Code	Manufacturer	Address	City, State, Zip Code
S3109	FELLER	72 VERONICA AVE UNIT 4	SUMMERSET NJ 08873
S4246	JAPAN SERVO CO LTD	7 KANDA MITOSHIRO--CHO CHIYODA--KU	TOKYO JAPAN
TK0860	LABEL GRAPHICS	6700 SW BRADBURY CT	PORTLAND OR 97224
TK1149	ALMAN INC	97 THORNWOOD RD	STAMFORD CT 06903--2617
TK1159	IMPROVED PRODUCTS	3400 OLYMPIC STREET	SPRINGFIELD OR 97477
TK1163	POLYCAST INC	9898 SW TIGARD ST	TIGARD OR 97223
TK1326	NORTHWEST FOURSIDE INC	18224 SW 100TH CT	TUALATIN OR 97062
TK1908	PLASTIC MOLDED PRODUCTS	4336 SO ADAMS	TACOMA WA 98409
TK1918	SHIN--ETSU POLYMER AMERICA INC	1181 NORTH 4TH ST	SAN JOSE CA 95112
TK1935	ACCRA--FAB INC	11007 NE 37TH CIRCLE	VANCOUVER WA 98682
TK2045	ITW CHRONOMATIC	4126 N NASHVILLE AVE	CHIGAGO IL 60634
TK2280	ESCORT INSTRUMENTS CORP	2--FL NO 37 POA HSIN RD PO BOX 3--20 MUCHA	TAIPEI TAIWAN ROC 00080
TK2432	UNION ELECTRIC	15/F #1, FU--SHING N. ROAD	TAIPEI, TAIWAN ROC
TK2469	UNITREK CORPORATION	3000 LEWIS & CLARK WAY SUITE #2	VANCOUVER WA 98601
TK6056	ASTEK USA	2880 SAN TOMES EXPRESSWAY SUITE 200	SANTA CLARA CA 95051
0JR05	TRIQUEST CORP	3000 LEWIS AND CLARK HWY	VANCOUVER WA 98661--2999
0J7N9	MCX INC	30608 SAN ANTONIO ST	HAYWARD CA 94544
0J9P9	GEROME MFG CO INC	PO BOX 737	NEWBERG OR 97132
0KBZ5	MORELLIS Q & D PLASTICS	1812 16TH AVE	FOREST GROVE OR 97116
0KB00	SCHRAMM PLASTIC FABRICATORS	7885 SW HUNZIKER	TIGARD OR 97223
0KB01	STAUFFER SUPPLY	810 SE SHERMAN	PORTLAND OR 97214
05469	BEARINGS INC	3634 EUCLID P O BOX 6925	CLEVELAND OH 44101
07416	NELSON NAME PLATE CO	3191 CASITAS	LOS ANGELES CA 90039--2410
13103	THERMALLOY CO INC	2021 W VALLEY VIEW LN PO BOX 810839	DALLAS TX 75381
24931	SPECIALTY CONNECTOR CO INC	2100 EARLYWOOD DR PO BOX 547	FRANKLIN IN 46131
30817	INSTRUMENT SPECIALTIES CO INC	EXIT 53 RT 80 BOX A	DELAWARE WATER GAP PA 18327
52152	MINNESOTA MINING AND MFG CO INDUSTRIAL SPECIALTIES DIV	3M CENTER	ST PAUL MN 55144--0001
55335	JKL COMPONENTS CORP	13343 PAXTON STREET	PACOIMA CA 91331
70903	COOPER BELDEN ELECTRONICS WIRE AND CABLE SUB OF COOPER INDUSTRIES INC		
73743	FISCHER SPECIAL MFG CO	111 INDUSTRIAL RD	COLD SPRING KY 41076--9749
75915	LITTELFUSE INC SUB TRACOR INC	800 E NORTHWEST HWY	DES PLAINES IL 60016--3049
80009	TEKTRONIX INC	14150 SW KARL BRAUN DR PO BOX 500	BEAVERTON OR 97077--0001

Replaceable Mechanical Parts

Fig. & Index No.	Tektronix Part No.	Serial No.		Qty	12345 Name & Description	Mfr. Code	Mfr. Part No.
		Effective	Dscont				
10-1-1	334-8202-00			1	MARKER,IDENT:MKD HANDLE	80009	334820200
-2	390-1106-00			1	CABINET,OSC:ALUMINUM	TK1935	ORDER BY DESC
-3	367-0289-00			1	HANDLE,CARRYING:13.855,SST,	0JR05	ORDER BY DESC
-4	212-0144-00			2	SCREW,TPG,TF:8-16 X 0.562 L,PLASTI,SPCL HD	0KB01	ORDER BY DESC
-5	348-0659-00			2	FOOT,CABINET:BLACK POLYURETHANE	0JR05	ORDER BY DESC
-6	-----			1	CABINET,OSC:ALUMINUM (NOT REPL, ORDER 390-1106-XX)		
-7	211-0730-00			1	SCR,ASSEM WSHR:6-32 X 0.375,PNH,STL CD PL	0KB01	ORDER BY DESC
-8	334-8203-00			1	MARKER,IDENT:MKD REAR COVER SUPPLY INFO	80009	334820300
-9	159-0277-00			1	FUSE,CARTRIDGE:5 X 20MM,3A,250V,5 SEC (STANDARD)	75915	235003
-10	159-0311-00			1	FUSE,CARTRIDGE:METRIC,1.5A,250V,FAST (OPTIONS A1,A2,A3,A4,A5)	TK2280	62-25608-1U
-11	211-0691-00			4	SCREW,MACHINE:6-32 X 0.625,PNH,STL	0KB01	ORDER BY DESC
-12	334-8494-00			1	MARKER,IDENT:MKD	80009	334849400
-13	200-3971-01			1	COVER,REAR:W/FEET AND LABELS	TK1163	200-3971-01
-14	161-0230-01			1	CABLE ASSY,PWR,:3,18 AWG,92 L,SVT,TAN (STANDARD ACCESSORY)	TK2432	ORDER BY DESC
-15	343-1213-00			1	CLAMP,PWR CORD:POLYIMIDE (STANDARD ACCESSORY)	TK1163	ORDER BY DESC

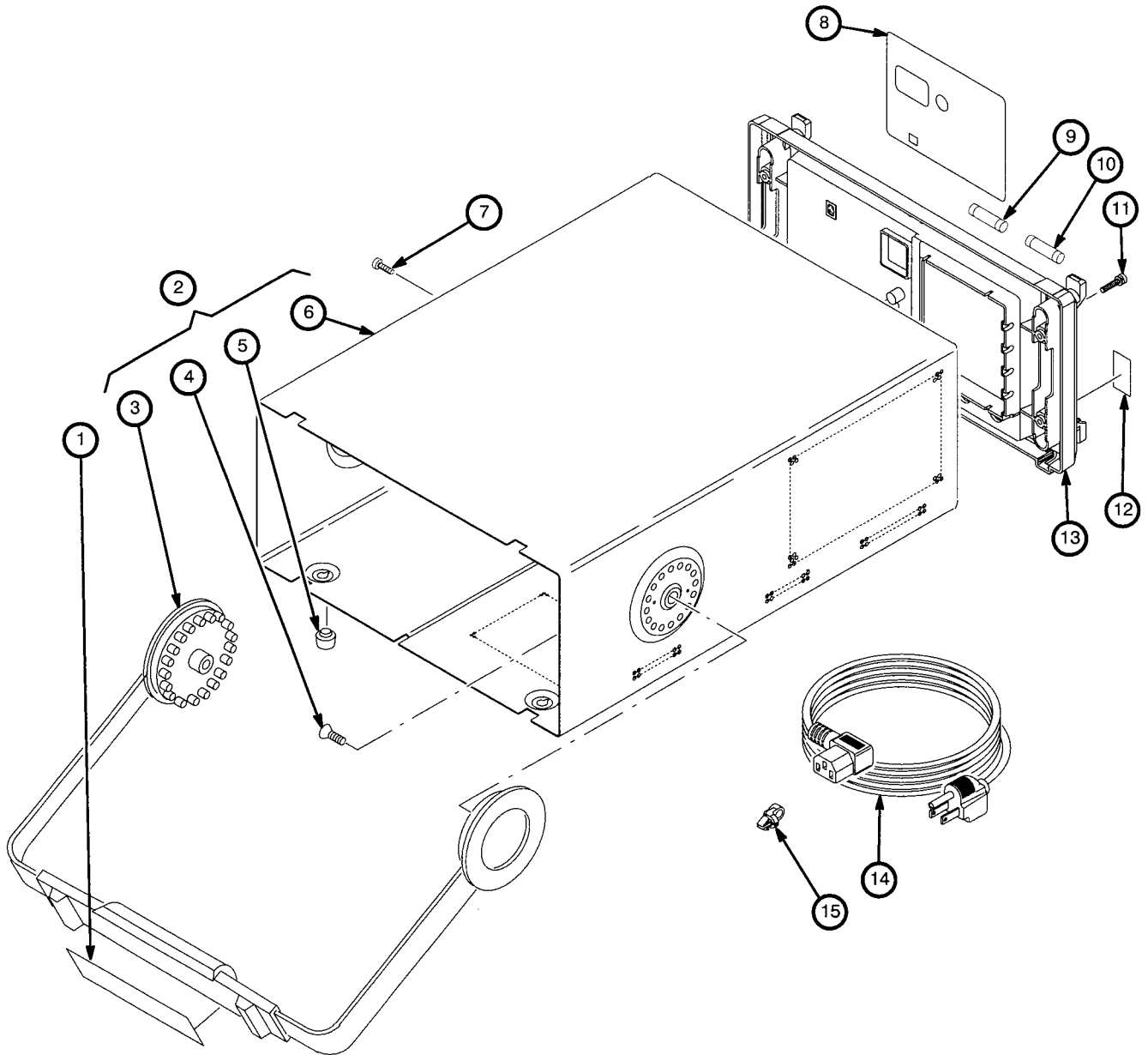

Figure 10-1: Cabinet and Rear

Replaceable Mechanical Parts

Fig. & Index No.	Tektronix Part No.	Serial No.		Qty	12345 Name & Description	Mfr. Code	Mfr. Part No.
		Effective	Dscont				
10-2-1	200-3232-01			1	COVER,FRONT:ASB	TK1908	ORDER BY DESC
-2	334-8422-00			1	MARKER,IDENT:MKD INST NOMENCLATURE (TAS 475 ONLY)	80009	334842200
	334-8424-00			1	MARKER,IDENT:MKD INST NOMENCLATURE (TAS 485 ONLY)	80009	334842400
-3	101-0139-00			1	TRIM,DECORATIVE:	80009	101013900
-4	378-0199-03			1	FILTER,LT,CRT:BLUE,3.415 X 4.105 X 0.030THK	OKB00	378019903
-5	260-2561-00			1	SWITCH,PB:BEZEL	80009	260256100
-6	-----			1	FLEX CIRCUIT:BEZEL (SEE A9 REPL)		
-7	-----			1	CIRCUIT BD ASSY:FRONT PANEL (SEE A4 REPL)		
-8	260-2538-00			1	SWITCH SET:IMPLICIT	TK1918	ORDER BY DESC
-9	214-1126-01			2	SPRING,FLAT:0.7 X 0.125,CU BE GOLD CLR	80009	214112601
-10	214-0274-00			2	BALL,BEARING:0.125 DIA,SST,GRADE 100	05469	ORDER BY DESC
-11	105-1031-00			2	ACTUATOR SW AS:12 POSITION	TK2045	ORDER BY DESC
-12	131-5341-00			1	CONTACT,ELEC:ESD,CU-BE ALLOY	TK1326	ORDER BY DESC
-13	366-2163-00			16	PUSH BUTTON:IVORY GRAY,OVAL	80009	366216300
-14	-----			1	CIRCUIT BD ASSY:FRONT PANEL MODULE (SEE A62 REPL)	80009	672136200
-15	380-0990-00			1	HOUSING,FR PNL:	80009	380099000
-16	333-3960-00			1	PANEL,FRONT:PLASTIC,Q1,Q1/2	80009	333396000
-17	384-1689-01			6	SHAFT EXTENDER:ACETAL	80009	384168901
-18	366-2111-00			3	KNOB:SMALL,FLUTED	TK1163	ORDER BY DESC
-19	131-5142-00			1	CONTACT,ELEC:PROBE ADJUST	TK1935	ORDER BY DESC
-20	366-2113-00			3	KNOB:MEDIUM,DETENTED	TK1163	ORDER BY DESC
-21	366-2164-00			10	PUSH BUTTON:SMOKE TAN	80009	366216400

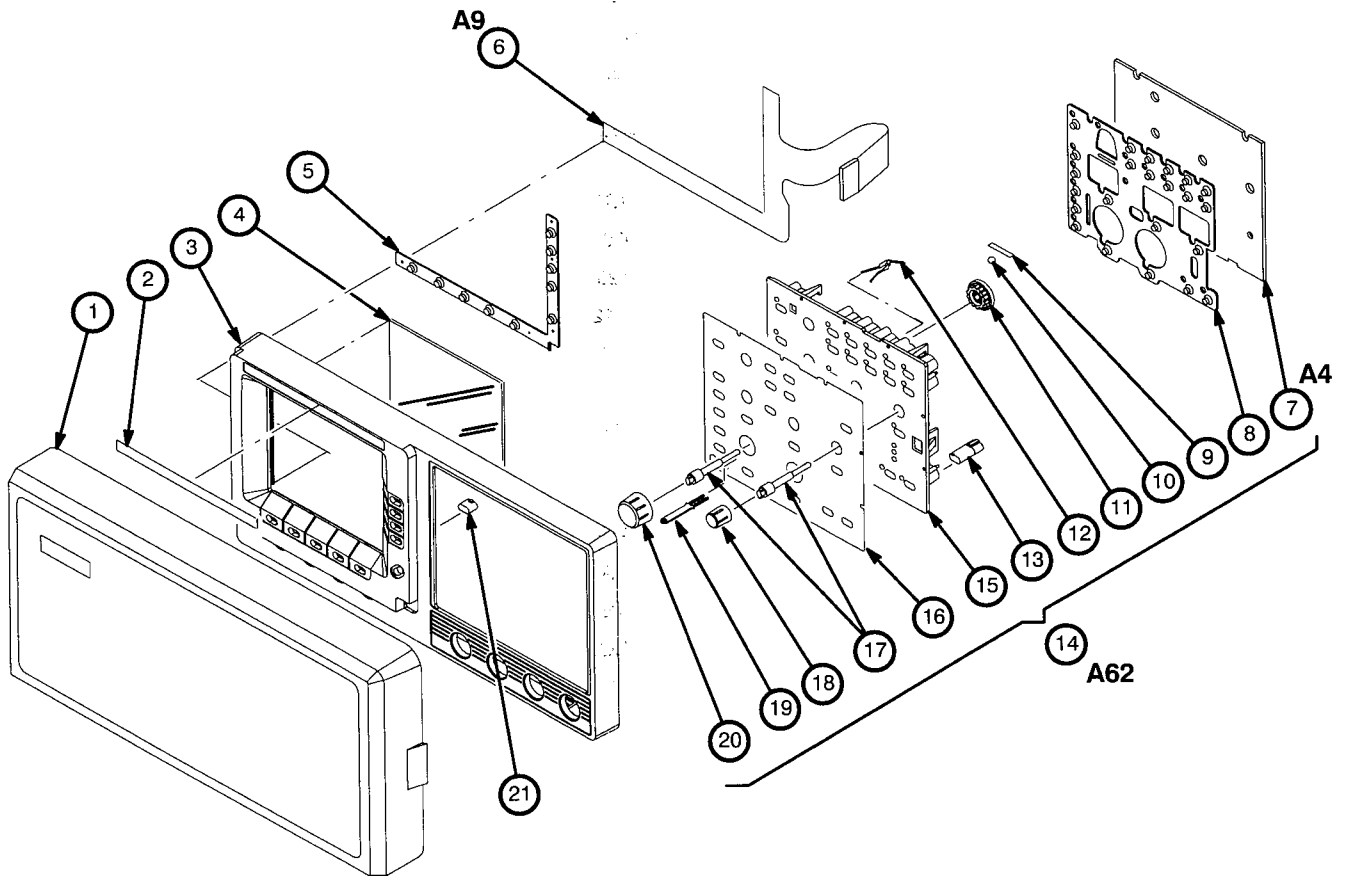

Figure 10-2: Front Panel Assembly

Replaceable Mechanical Parts

10-10
 10-11
 10-12
 10-13
 10-14
 10-15
 10-16
 10-17
 10-18
 10-19
 10-20
 10-21
 10-22
 10-23
 10-24
 10-25
 10-26
 10-27
 10-28
 10-29
 10-30
 10-31
 10-32
 10-33
 10-34
 10-35
 10-36
 10-37
 10-38
 10-39
 10-40
 10-41
 10-42
 10-43
 10-44
 10-45
 10-46
 10-47
 10-48
 10-49
 10-50
 10-51
 10-52
 10-53
 10-54
 10-55
 10-56
 10-57
 10-58
 10-59
 10-60
 10-61
 10-62
 10-63
 10-64
 10-65
 10-66
 10-67
 10-68
 10-69
 10-70
 10-71
 10-72
 10-73
 10-74
 10-75
 10-76
 10-77
 10-78
 10-79
 10-80
 10-81
 10-82
 10-83
 10-84
 10-85
 10-86
 10-87
 10-88
 10-89
 10-90
 10-91
 10-92
 10-93
 10-94
 10-95
 10-96
 10-97
 10-98
 10-99
 10-100

Fig. & Index No.	Tektronix Part No.	Serial No.		Qty	12345 Name & Description	Mfr. Code	Mfr. Part No.
		Effective	Dscont				
10-3-1	407-4130-00	B010100	B010570	1	BRACKET,CRT:FRONT (TAS475 ONLY)	80009	407413000
	407-4130-01	B010571		1	BRACKET,CRT:FRONT (TAS475 ONLY)	80009	407413001
	407-4130-00	B010100	B010328	1	BRACKET,CRT:FRONT (TAS485 ONLY)	80009	407413000
	407-4130-01	B010329		1	BRACKET,CRT:FRONT (TAS485 ONLY)	80009	407413001
-2	337-2926-03			1	SHLD,IMPLOSION:4.44 X 3.67 X 0.06,CLEAR	TK1159	ORDER BY DESC
-3	348-0660-00			4	CUSHION,CRT:POLYURETHANE	80009	348066000
-4	-----			1	ELECTRON TUBE:CRT (SEE A64 REPL)		
-5	344-0347-00			1	CLIP,ELECTRICAL:ANODE,0.72OD,NYLON	80009	344034700
-6	386-4443-00			1	SUPPORT,SHIELD:CRT,FRONT,PLASTIC	80009	386444300
-7	-----			1	LEAD,ELECTRICAL:DESCRETE,SDI/IDC,2,22 AWG (SEE P75 REPL)		
-8	-----			1	LEAD,ELECTRICAL:DESCRETE,SDI/IDC,2,22 AWG (SEE P74 REPL)		
-9	334-1951-00			1	MARKER,IDENT:MKD WARNING,CRT VOLTAGES	TK0860	ORDER BY DESC
-10	334-1379-00			1	MARKER,IDENT:MKD HI VACUUM	07416	ORDER BY DESC
-11	337-3487-00			1	SHIELD,ELEC:CRT,STL (TAS475 ONLY)	0J9P9	337348700
	337-3893-00			1	SHIELD,ELEC:CRT,STL (TAS485 ONLY)	0J9P9	337389300
-12	426-2426-00			1	FRAME,FAN MTG:POLYCARBONATE	TK1163	426-2426-00
-13	-----			1	FAN,TUBEAXIAL:12V,1.72W,42 CFM (SEE B90 REPL)		
-14	200-0616-02			1	COVER,CRT SKT:1.78 DIA X 0.2 D,WHITEPOLY	80009	200061602
-15	-----			1	CA ASSY,SP:DESCETE,SDI,9,26 AWG,7.4L (SEE P76 REPL)		
-16	131-5546-00			1	CONN,CONTACT:STATIC	80009	131554600
-17	407-4129-00			1	BRACKET,REAR:REAR OUT	80009	407412900
-18	213-0882-00			17	SCREW,TPG,TR:6-32 X 0.437 TAPTITE,PNH,STL	0KB01	ORDER BY DESC
-19	-----			1	POWER SUPPLY:LOW POWER VERSION (SEE A63 REPL)		
-20	343-0549-00			1	STRAP,TIEDOWN,E:0.098W X 4.0L	TK1499	HW-047
-21	-----			1	CA ASSY RF:DESCRETE,SDI/RFD,22 AWG,8.625 L (SEE J21 REPL)		
-22	407-4196-00			1	BRACKET,STD:ALUMINUM	80009	407419600
-23	441-1982-00			1	CHASSIS ASSY:ALUMINUM	80009	441198200
-24	348-0150-00			1	GROMMET,PLASTIC:DK GRAY,U-SHAPE,0.66 ID	0KBZ5	ORDER BY DESC
-25	348-1334-00			1	SHLD,GSKT ELEK:CLIP ON EMI,0.46 L (TAS475 ONLY)	30817	97-605-09-005W
	348-1334-00	B010100	B010320	1	SHLD,GSKT ELEK:CLIP ON EMI,0.46 L (TAS485 ONLY)	30817	97-605-09-005W
	348-1258-00	B010321		1	SHLD,GASKET,ELE:2 LAYER,0.094 X 0.188 X 8.750 (TAS485 ONLY)	80009	348-1258-00

Replaceable Mechanical Parts

Fig. & Index No.	Tektronix Part No.	Serial No.		Qty	12345 Name & Description	Mfr. Code	Mfr. Part No.
		Effective	Dscont				
10-3-26	384-1370-00			1	EXTENSION SHAFT:4.68 L,MOLDED PLASTIC	0JR05	ORDER BY DESC
-27	366-2168-00			1	PUSH BUTTON:ON/OFF	80009	366216800
-28	351-0914-00			1	GUIDE,LIGHT:GRATICULE	80009	351091400
-29	384-1689-01			4	SHAFT EXTENDER:ACETAL	80009	384168901
-30	366-2169-00			4	KNOB:THUMB/WHEEL	80009	366216900

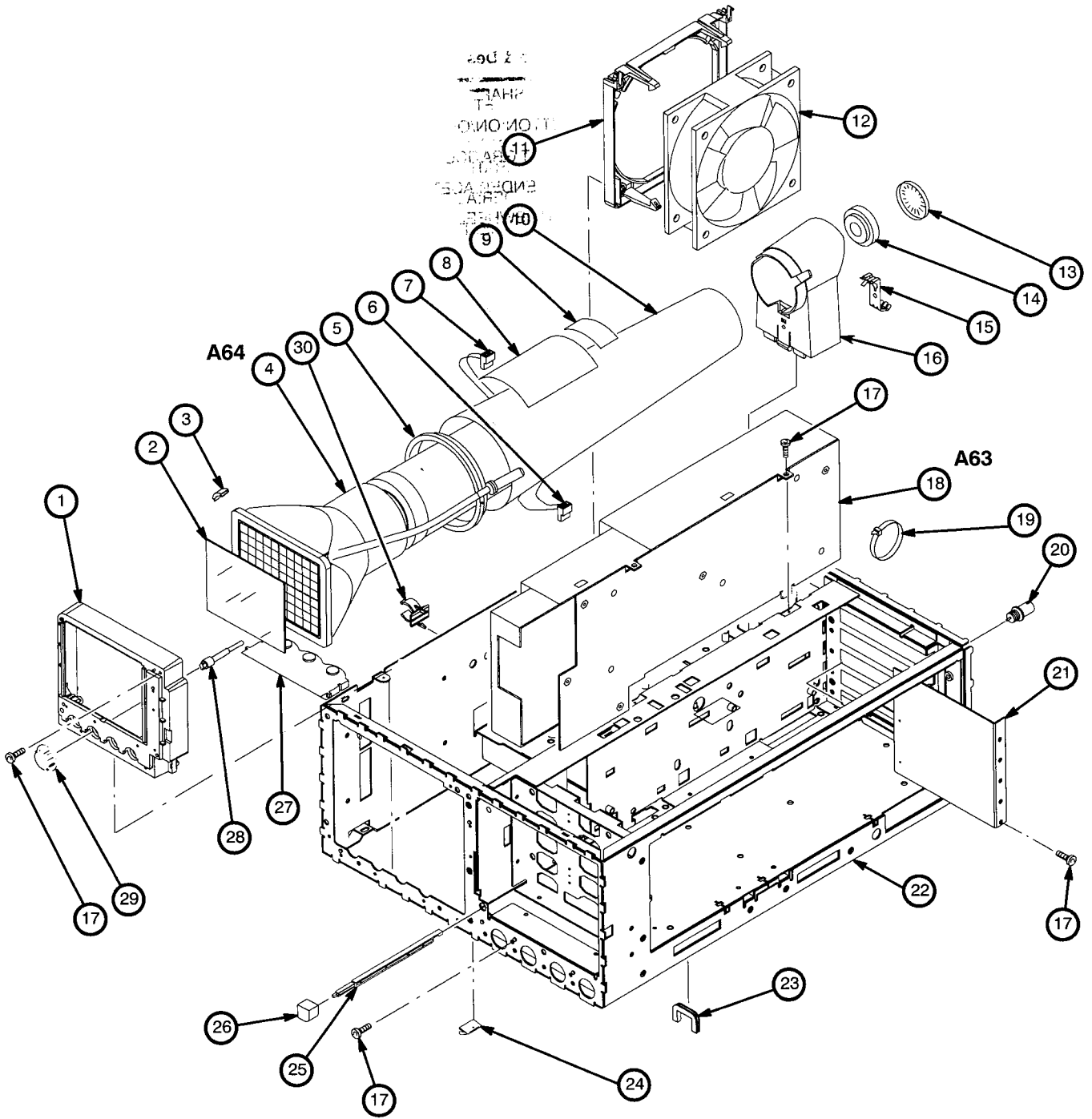

Figure 10-3: Chassis

Replaceable Mechanical Parts

Fig. & Index No.	Tektronix Part No.	Serial No. Effective Dscont	Qty	12345 Name & Description	Mfr. Code	Mfr. Part No.
10-4-1	-----		2	LAMPINCAND:14V,0.08A,WEDGE BASE,T1.75 (SEE A2DS1,DS2 REPL)		
-2	196-3405-00		1	LEAD,ELECTRICAL:4.0L,W/AMPRING TERMINAL	80009	196340500
-3	210-0457-00		1	NUT,PL,ASSEM.WA:6.32 X 0.312,STL CD PL	OKB01	ORDER BY DESC
-4	334-8543-00		1	MARKER,IDENT:0.500 IN DIA BLANK MYLAR	80009	334854300
-5	213-0882-00		7	SCREW,TPG,TR:6-32 X 0.437 TAPTITE,PNH,STL	OKB01	ORDER BY DESC
-6	-----		1	CIRCUIT BD ASSY:CPU (SEE A5 REPL)		
-7	-----		1	DELAY LINE,ELEC:VERTICAL (SEE DL68 REPL)		
-8	-----		1	CA ASSY, SP:FLAT FLEX,FLX,23,26 AWG,6.5L (SEE A3W66 REPL)		
-9	342-0960-00		1	INSULATOR,SHEET:POLYCARBONATE	80009	342096000
-10	337-3880-00		1	SHIELD,ELEC:PLASTIC,HIGHT VOLTAGE	80009	337388000
-11	334-0286-00		2	LABEL:MKD ASMZ80 OPT 1C	80009	334028600
-12	-----		1	CIRCUIT BD ASSY:DISPLAY DRIVER (SEE A3 REPL)		
-13	342-0324-00		2	INSULATOR,DISK:TRANSISTOR,NYLON	13103	7717-5N
-14	214-2593-00		2	HEAT SINK,XSTR:TO-5,AL	13103	2257B
-15	337-3904-00		1	SHIELD,ELEC:CIRCUIT BOARD,TSA465	TK1326	337-3904-00
-16	386-0048-00		2	SUPPORT,CHASSIS:BRASS W/NICKLE PLATING	80009	386004800
-17	407-4131-00		1	BRACKET,ATTEN:BNC,BRASS	80009	407413100
-18	337-3713-01		1	SHIELD,ELEC:ATTENUATOR	TK1935	337-3713-01
-19	-----		4	CONN,RF JACK:BNC,50 OHM,FEMALE,STR (SEE A1J10,11,20,21-REPL)		
-20	210-1039-00		4	WASHER,LOCK:0.521 ID,INT,0.025 THK,SST (QTY3, TAS475) (QTY 4, TAS485)	OKB01	1224-02-00-0541
-21	220-0497-00		4	NUT,PLAIN,HEX:0.5-28 X 0.532 HEX,BRS CD PL (QTY3, TAS475) (QTY 4, TAS485)	73743	ORDER BY DESC
-22	-----		1	CIRCUIT BD ASSY:ANALOG (SEE A1 REPL)		
-23	343-0775-00	B010721	1	CABLE,CLAMP:RIBBON,1.0 X 1.0.GRAY POLY (TAS475 ONLY)	52152	3484-1000
	343-0775-00	B010530	1	CABLE,CLAMP:RIBBON,1.0 X 1.0.GRAY POLY (TAS485 ONLY)	52152	3484-1000
-24	-----		1	CA ASSY,SP:FLAT FLEX,;FLX,16,26 AWG,13.7 L (SEE P30 REPL)		
-25	-----		1	CA ASSY,SP:RIBBON,;IDC,40,28 AWG,3.5 L,2X2 (SEE P50 REPL)		
-26	-----		1	CA ASSY,SP:FLAT FLEX,;FLX,2,26 AWG,7.65 L (SEE P80 REPL)		
-27	-----		1	CA ASSY,SP:FLAT FLEX,;FLX,5,26 AWG,8.7 L (SEE P84 REPL)		
-28	-----		1	CIRCUIT BD ASSY:DISPLAY CONTROL (SEE A2 REPL)		

Replaceable Mechanical Parts

Fig. & Index No.	Tektronix Part No.	Serial No. Effective Dscont	Qty	12345 Name & Description	Mfr. Code	Mfr. Part No.
STANDARD ACCESSORIES						
10-5-1	161-0104-05		1	CABLE ASSY,PWR.:3,18 AWG,240V,98.0 L (OPTION A3-AUSTRALIAN)	S3109	SAA/3-OD3CCFC3X
5-2	161-0104-06		1	CABLE ASSY,PWR.:3 X 0.75MM SQ,220V,98.0 L (OPTION A1-EUROPEAN)	S3109	VIIGSOPO-HO5VVF
5-3	161-0104-07		1	CABLE ASSY,PWR.:3,1.0MM SQ,240 VOLT,2.5 M (OPTION A2-UNITED KINGDOM)	S3109	ORDER BY DESC
5-4	161-0104-08		1	CABLE ASSY,PWR.:3,18 AWG,98 L,SVT,GREY/BLK (OPTION A4-NORTH AMERICAN)	70903	ORDER BY DESC
5-5	161-0167-00		1	CABLE ASSY,PWR.:3.0 X 0.75,6A,240V,2.5M L (OPTION A5-SWITZERLAND)	S3109	ORDER BY DESC
-----			1	CABLE ASSY,PWR.:3,18 AWG,92 L,SVT,TAN (STANDARD, SEE FIGURE 10-1-15)		
-----			1	ACCESSORY PKG:(2)P6109B 2M PROBES W/ACC		
070-8720-00			1	MANUAL,TECH:TAS475,TAS485 REF	80009	070852200
070-8688-01			1	MANUAL,TECH:INSTRUCTION,MODULE LEVEL	80009	070868801
070-8690-01			1	MANUAL,TECH:USER,XYZS OF OSCILLOSCOPE	80009	070869000
-----			1	FUSE,CARTRIDGE:5 X 20MM,3A,250V,5 SEC (SEE FIGURE 10-1-9)		
-----			1	FUSE,CARTRIDGE:METRIC,1.5A,250V,FAST (OPTIONS A1, A2, A3, A4, A5) (SEE FIG. 10-1-10)		
-----			1	CLAMPPWR CORD:POLYIMIDE (SEE FIGURE 10-1-16)		
OPTIONAL ACCESSORIES						
003-1472-00			1	HAND TOOL:CLAMP,DETENT SPRING	80009	003147200
003-1473-00			1	HAND TOOL:SPRING INSERTION	80009	003147300
070-8878-00			1	MANUAL,TECH:SERVICE,COMPONENT LEVEL	80009	070887800
016-1154-00			1	HOOD ASSEMBLY:2KDSO	80009	016115400
016-1166-00			1	RACK MOUNT KIT:TAS SERIES	80009	016116600

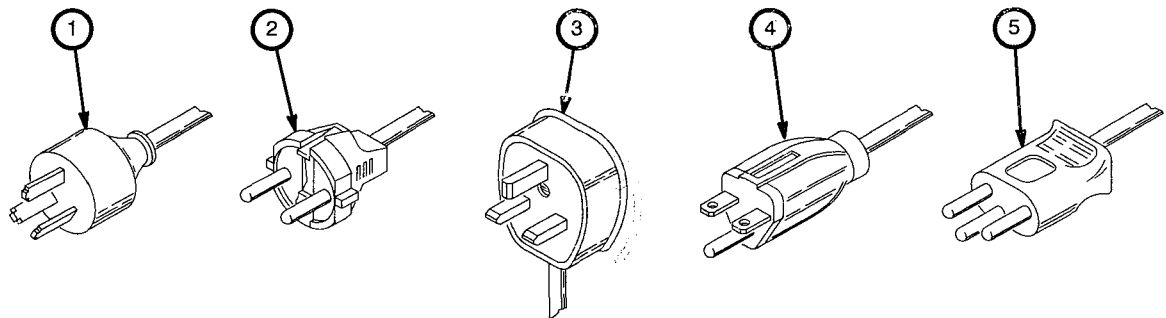

Figure 10-5: Accessories